

DUOX

**FERMAX**

DUOX SYSTEM

TECHNICAL BOOK  
SECTION I



## DUOX TECHNICAL BOOK

The DUOX technical book consists of two sections:



- Section I: Description of the DUOX system (Cod. 970122I-1)
- Section II: DUOX installation diagrams (Cod. 970122I-2)











### DUOX technical book - Section I

Code 970122I-1 V02\_18

This technical document has been edited by FERMAX ELECTRÓNICA S.A.U. for informational purposes, and the company reserves the right to modify any of the technical specifications of the products referred to herein at any time without prior notice. These changes shall be reflected in later editions of the same document.

## INDEX

	<b>1. INTRODUCTION</b>	<b>6</b>
	1.1 DUOX: EASE OF INSTALLATION	6
	1.2 COMPONENTS OF A DUOX SYSTEM	7
	1.2.1 OUTDOOR PANEL	7
	1.2.2 AUDIO GUARD UNIT	7
	1.2.3 POWER SUPPLY SET	8
	1.2.4 LINE ADAPTER	8
	1.2.5 REGENERATORS	8
	1.2.6 APARTMENT TERMINALS: MONITORS AND TELEPHONES	8
	1.3 PRINCIPAL TECHNICAL SPECIFICATIONS OF THE DUOX SYSTEM	9
	1.4 OPERATING PRINCIPLES OF THE DUOX SYSTEM	10
	1.5 RECEIVING CALLS	12
	1.5.1 MAKING CALLS BASED ON THE CONFIGURATION OF THE OUTDOOR PANEL	12
	1.5.2 EXAMPLES OF THE CONFIGUR. OF OUTDOOR PANELS AND APARTMENT TERM.	13
	<b>2. DUOX OUTDOOR PANELS</b>	<b>20</b>
	2.1 DUOX AMPLIFIERS	20
	2.1.1 VIDEO AMPLIFI. FOR CITYLINE AND MARINE OUTDOOR PANELS WITH PUSHB.	21
	a) Settings	21
	b) Configuration	22
	c) Pre-wiring	24
	2.1.2 VIDEO AMPLIFIER FOR SKYLINE, DIRECT AND DIGITAL OUTDOOR PANELS	29
	a) Settings	29
	b) Configuration	31
	c) Pre-wiring	34
	2.1.3 AUDIO AMPLIF. FOR CITYLINE AND MARINE OUTDOOR PANELS WITH PUSHB.	39
	a) Settings	39
	b) Configuration	40
	c) Pre-wiring	42
	2.1.4 AUDIO AMPLIFIER FOR SKYLINE, DIRECT AND DIGITAL OUTDOOR PANELS	47
	a) Settings	47
	b) Configuration	49
	c) Pre-wiring	52
	2.2 ADVANCED PROGRAMMING	57
	2.2.1 MAPPING IN PUSHBUTTON PANELS	57
	2.2.2 MAPPING IN DIGITAL PANELS	62
	2.2.3 ADVANCED PROGRAMMING OPTIONS IN DIRECT PANELS	64
	<b>3. DUOX AUDIO GUARD UNIT</b>	<b>65</b>
	1. Control buttons	65
	2. Operation	66
	3. Connection terminals, technical specifications and default values	66

	<b>4. POWER SUPPLY SET: POWER SUPPLY + DUOX FILTER</b>	<b>68</b>
	<b>5. DUOX LINE ADAPTER</b>	<b>69</b>
	5.1 DEVICES WHICH INCLUDE A LINE ADAPTER	69
	5.2. WHERE TO INSTALL A LINE ADAPTER AND HOW TO CONFIGURE IT	71
	<b>6. DUOX REGENERATOR</b>	<b>75</b>
	6.1 DUOX 1S REGENERATOR (REF. 3256)	75
	6.2 DUOX 2S REGENERATOR (REF. 3253)	77
	6.3 DUOX MULTI-CHANNEL REGENERATOR 1S (REF. 3259)	80
	6.4 COMPARISON OF REGENERATORS	82
	<b>7. APARTMENT TERMINALS</b>	<b>82</b>
	<b>7.1 VEO XS MONITOR</b>	<b>83</b>
	Control buttons/LEDs	83
	Connections	83
	Monitor programming	84
	User settings	85
	Technical specifications	86
	<b>7.2 VEO MONITOR</b>	<b>87</b>
	Control buttons/LED	87
	Connections	87
	Monitor programming	88
	User settings	89
	Technical specifications	90
	<b>7.3 LOFT BASIC PLUS TELEPHONE</b>	<b>91</b>
	Control buttons	91
	Connections	91
	Telephone programming	92
	User settings	92
	Technical specifications	93
	<b>7.4 LOFT EXTRA TELEPHONE</b>	<b>93</b>
	Control buttons/LED	93
	Connections	93
	Telephone programming	94
	User settings	95
	Technical specifications	95
	<b>7.5 LOFT TELEPHONE</b>	<b>96</b>
	Control buttons/LEDs	96
	Connections	96
	Telephone programming	97
	User settings	98
	Technical specifications	99
	<b>8. DUOX RELAY</b>	<b>99</b>



## 9. DUOX INSTALLATIONS

101

<b>9.1 PRIOR CONSIDERATIONS REGARDING WIRING AND DUOX CONSUMPTION</b>	<b>101</b>
<b>9.2 BASIC VIDEO INSTALLATIONS (Monitors) AND MIXED INSTALLATIONS (Monitors + Telephones)</b>	<b>102</b>
9.2.1 EXAMPLE OF A DUOX BASIC INSTALLATION. 1 RISER	102
9.2.2 EXAMPLE OF A DUOX BASIC INSTALLATION. 2 RISERS	103
9.2.3 EXAMPLE OF A DUOX BASIC INSTALLATION. 3 RISERS	103
9.2.4 EXAMPLE OF A DUOX BASIC INSTALLATION. 4 RISERS	104
<b>9.3 BASIC AUDIO INSTALLATION (Telephones)</b>	<b>104</b>
<b>9.4 EXTENDED INSTALLATION</b>	<b>105</b>

## 1. INTRODUCTION

DUOX is the first completely digital video door communication system to be based on 2 non-polarised wires.

These specifications make it an extremely versatile and scalable system which is highly recommended in both new-build and replacement facilities. In the latter case, the DUOX system has a wide range of scope for application as a result of its flexibility, meaning that it can be installed using a wide range of wiring arrangements.

Its flexibility also extends to the level of choice afforded to users. Having originally decided to install a telephone in their apartment, users may change this for a monitor whenever they wish to.

DUOX makes it possible to have:

- Up to 10 outdoor panels and 10 guard units in the General Entrance.
- 99 blocks with up to 10 outdoor panels and 10 guard units in each of these.
- 99 sub-blocks with up to 10 outdoor panels in each of these.
- Up to 999,999 apartment addresses.

This is all possible with a limited number of intermediary elements.

### 1.1 DUOX: EASE OF INSTALLATION

With DUOX, it is possible to save time in installation, as a result of:

A) The limited number of elements required for installation:

- No distributors
- No switchers
- No decoders

B) Intuitive programming:

DUOX is extremely easy to programme. No additional elements are required for the set-up process:

- DUOX monitors can be programmed within seconds, directly from the terminal menu, which makes it possible for one single person to programme the installation.
- The pushbutton panels include a remarkable voice synthesis system which guides the person in charge of the installation through the programming process.

#### DUOX Video Door System Installation

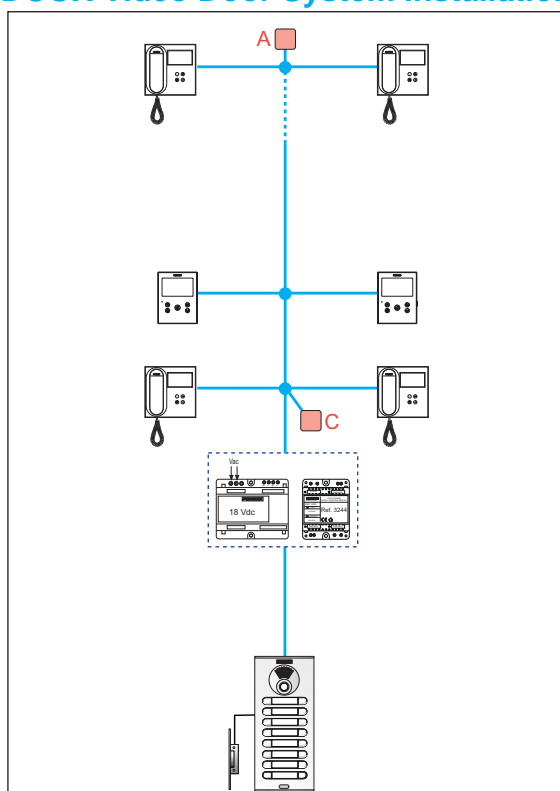

#### DUOX Door Installation

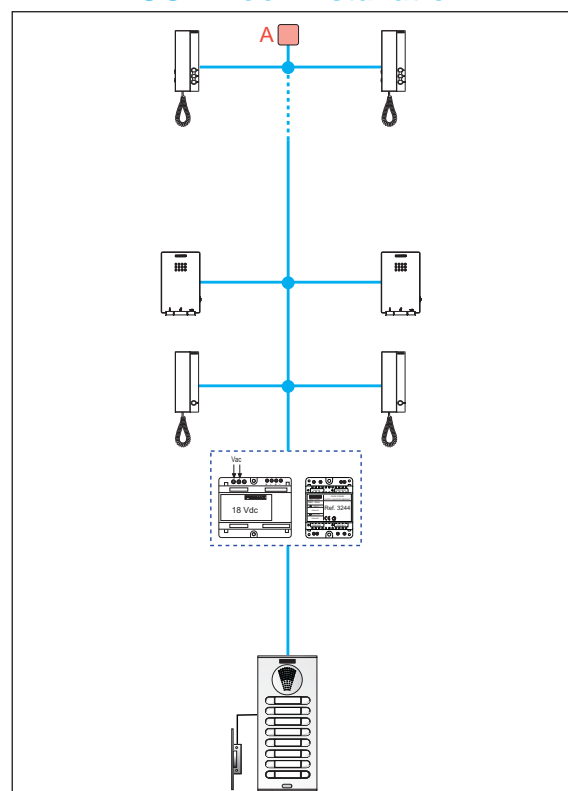

## 1.2 COMPONENTS OF A DUOX SYSTEM

The main components of the DUOX system are those which are present throughout all of the installations, regardless of the size of these.

### 1.2.1 OUTDOOR PANEL

These are available in all of the FERMAX styles: Cityline, Skyline and Marine.

Depending on their function (the way in which they make the call) and the intrinsic specifications of the model, the outdoor panels may be: Pushbutton, Direct or Digital.

They are available with video and audio.

For more information, *see subsection 2. DUOX outdoor panels.*

Outdoor panels with different aesthetics:

#### VIDEO

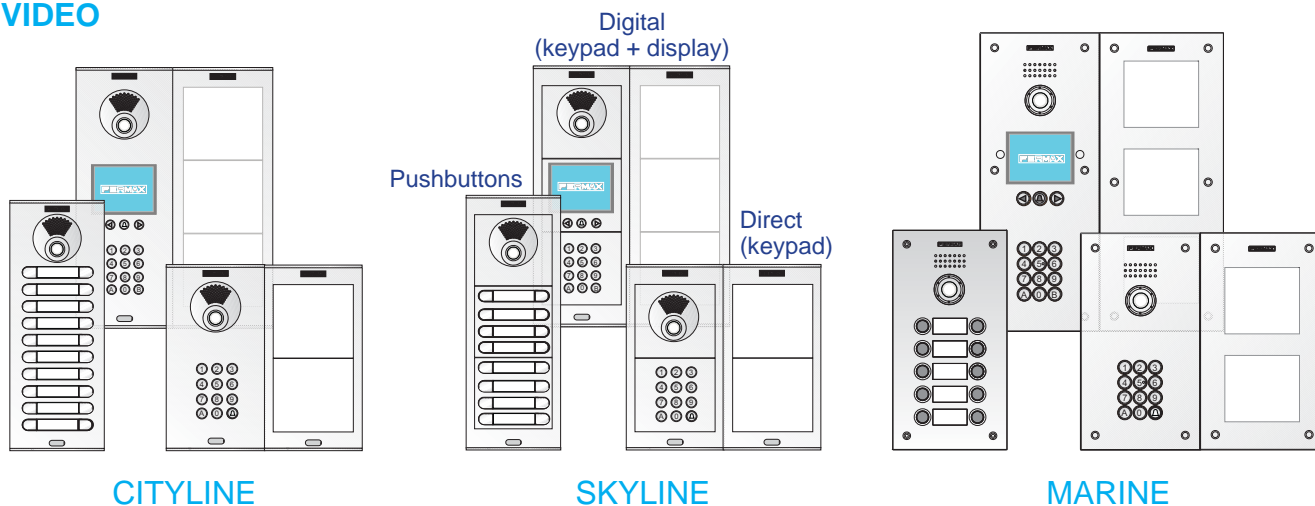

#### AUDIO

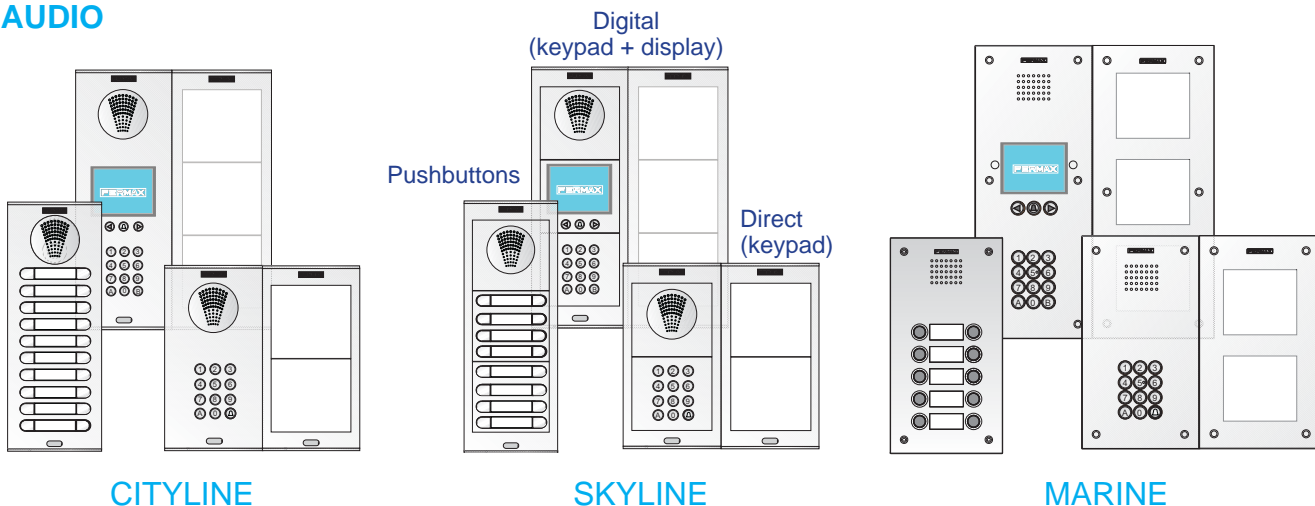

### 1.2.2 AUDIO GUARD UNIT

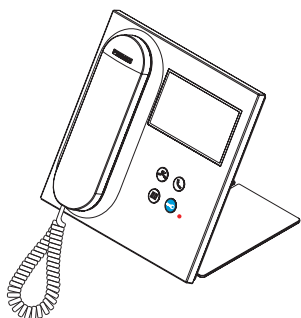

The DUOX system can be complemented with one or more Guard Units (in the general entrance and/or in internal blocks) which can be wall-mounted or desk-mounted.

The central unit of the guard unit acts as a “filter” between residents of a building and visitors.

For more information, *see subsection 3. DUOX Audio Guard Unit.*

*Note: It is also possible to refrain from employing the outdoor panel as long as there is at least 1 Guard Unit.*

### 1.2.3 POWER SUPPLY SET

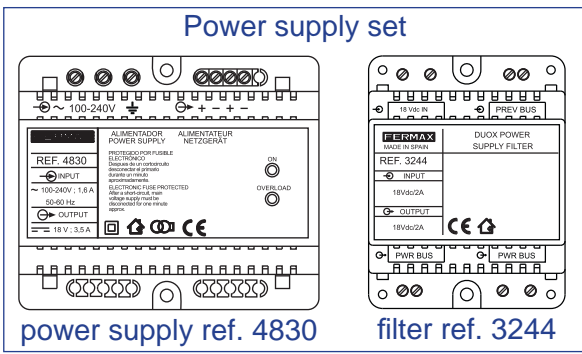

The power supply cannot be connected directly to the bus, given the DUOX system features, as the power supply and the data travel along the same wires. The power supplies must always be accompanied by the DUOX filter. We refer to the combination of the power supply and the filter as the “Power Supply Set”.

For more information, see subsection 4. Power supply set: Power supply + DUOX Filter.

### 1.2.4 LINE ADAPTER

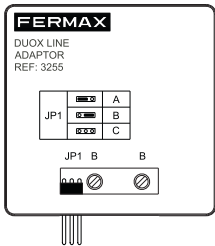

With the DUOX system it is necessary to adapt the transmission line. Line adapter ref. 3255 can be used for this purpose. This adapter balances impedances in the transmission line.

There are also other devices that include a line adapter in their structure. For more information, see subsection 5. DUOX line adapter.

### 1.2.5 REGENERATORS

The main function and purpose of a regenerator is to increase distances, risers and terminals in an installation.

There are 3 types of regenerators. Each one of these has its own specific technical characteristics and guidelines for usage.

For more information, see subsection 6. DUOX Regenerator.

Regenerator models:

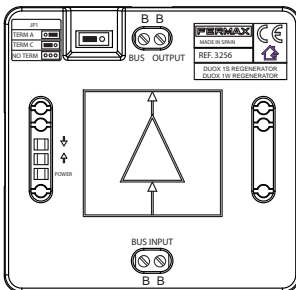

DUOXRegenerator 1 Output (ref. 3256)

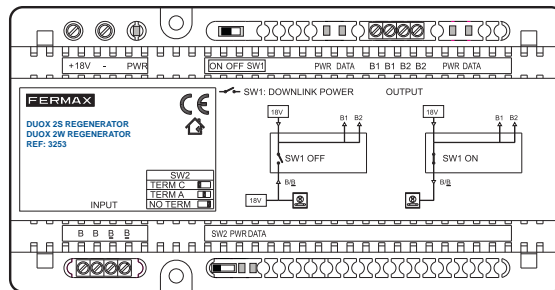

DUOXRegenerator 2 Outputs (ref. 3253)

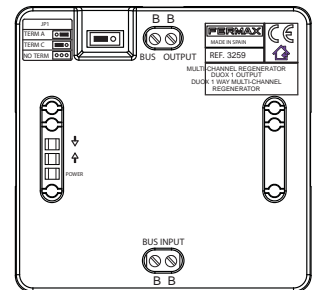

Regenerator Multi-channel DUOX 1 Output (ref. 3259)

### 1.2.6 APARTMENT TERMINALS: MONITORS AND TELEPHONES

For more information, see subsection 7. Apartment Terminals.

MONITORS		TELEPHONES		
VEO XS	VEO	LOFT BASIC PLUS	LOFT EXTRA	iLOFT



### 1.3 PRINCIPAL TECHNICAL SPECIFICATIONS OF THE DUOX SYSTEM

- A simplified installation system in two non-polar wires, which require neither floor distributors nor outdoor panel switchers. **This leads to a considerable reduction in installation time.**
- The signal transmission (audio, video and data) is completely digital, allowing it to maximise its capacity and robustness to noise and interference. **This ensures consistent audio and video quality throughout the installation.**
- Voice-guided programming in outdoor panels and via a graphic menu on monitors.
- Substitution of a telephone with a monitor at the apartment, without requiring additional accessories.

Wiring	Flexible topology with 2 non-polarised wires.
Supported cables	- Parallel (2 x 1.0 mm <sup>2</sup> ). <b>Recommended cable Ref. 5925.</b> - Twisted pair - UTP - 2 doorbell wires - 4+N cable
Distance between edges of the installation	Up to 3,000 metres with regeneration.
Distance between regenerators in a terminal-free bus	Up to 500 metres.
Connection of terminals	Connections are made using a connection strip, without the need to install distributors.
Conversation mode	Full-duplex in models with headsets. Natural conversation in hands-free models.
Power supply voltage	18Vdc
Maximum conversation time	90 seconds.
Maximum number of addressable apartments	999,999 (6-digit addressing).
Structure of the installation	General Entrance (up to 10 outdoor panels and 10 guard units). 99 blocks (up to 10 outdoor panels and 10 guard units in each block). 99 sub-blocks (up to 10 outdoor panels in each sub-block).
Maximum number of terminals per apartment	3
Maximum number of guard units per installation	10 in the General Entrance / 10 per Block.

- Line adapters are required to balance impedances.
- Privacy (complete confidentiality) in conversations. It is not possible to listen to a third-party conversation (even between terminals installed in the same apartment).

If a conversation is underway, the system will not function for the rest of the terminals (during a pre-established time period).

- Auto-start.

The apartment terminals can be auto-started with the outdoor panel as long as the system is not busy. The monitors have a specific button for this function, whereas in the case of telephones, auto-start takes place when the headset is picked up or when audio communication is established (headset-free model: hands-free).

Notes:

- The availability of this function depends on the type of the installation. See subsection 7. Apartment terminals.
- If a call is received from another panel, when the conversation has been completed, for 15 seconds, **auto switch-on** will happen with that panel.

- Programming of the Lock Release Time and the Exit Pushbutton Time (egress).

Both times can be quickly and easily programmed for the lock release.

- Easy extension.

It is possible to quickly and easily create enclosures from various exterior access points to various internal blocks.

### DUOX Video Door System Installation

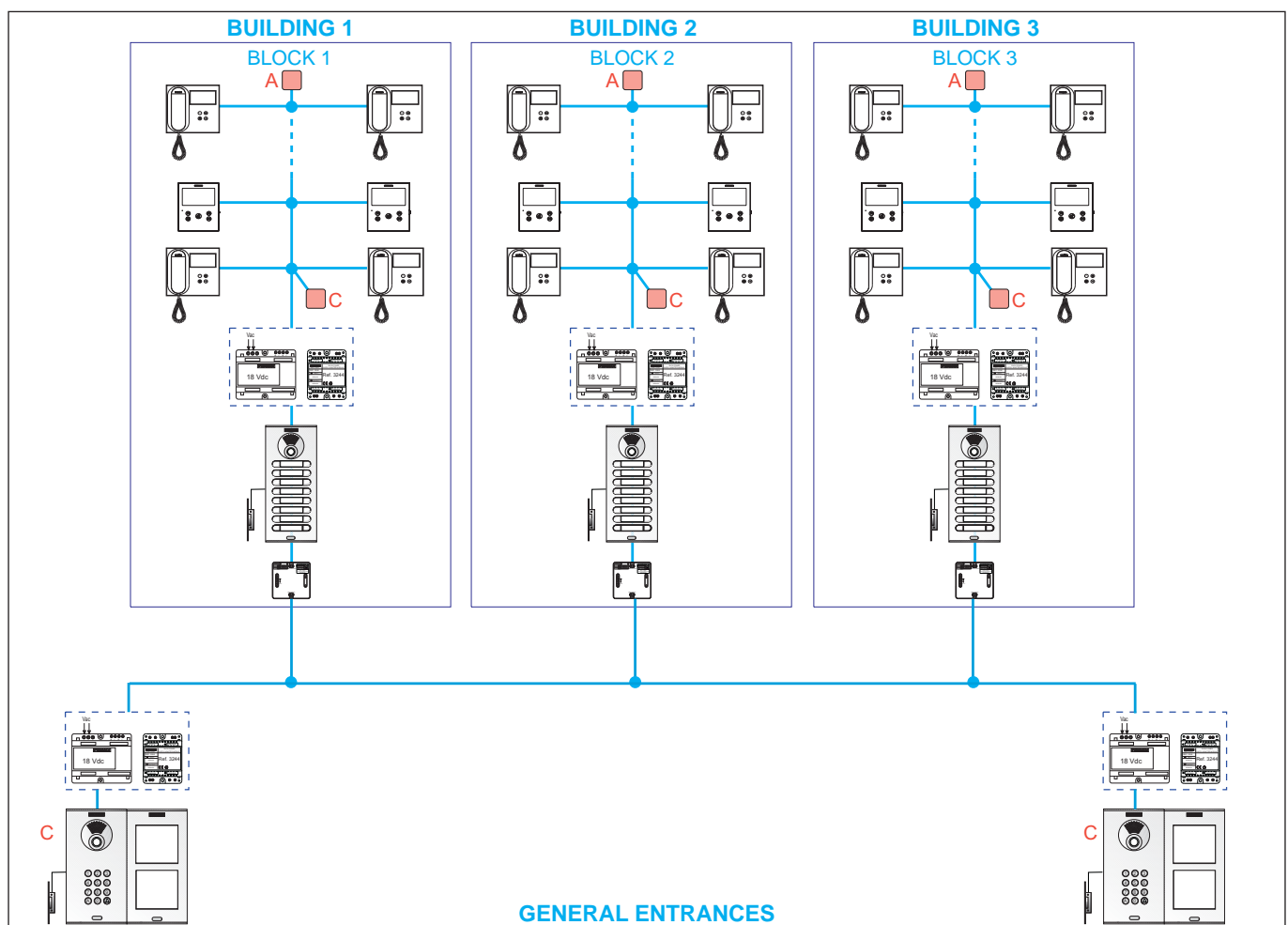

## 1.4 OPERATING PRINCIPLES OF THE DUOX SYSTEM

The call that is being made from the outdoor panel is sent through the bus to the terminal that is being called. When the terminal that is being called picks up, a communication channel is established between the outdoor panel and the aforementioned apartment terminal.

Each apartment terminal (telephone/monitor) is programmed with a 6-digit address which identifies the terminal within the installation and distinguishes it from the other terminals.

- **Call:**

When a call is made from the outdoor panel to an apartment, the amplifier that is incorporated within the panel generates the corresponding "call code/call direction" and sends it through the bus.

The type of outdoor panel will determine how the call is made and how the call code is generated:

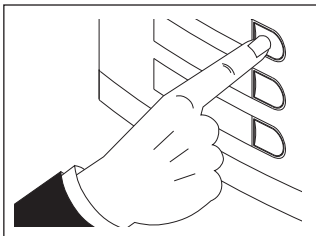
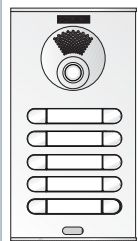

**Pushbutton outdoor panels:** In the pushbutton panels, each pushbutton corresponds to a specific “call code/call direction”. This means that the call to the apartment is placed by pressing the corresponding call button.

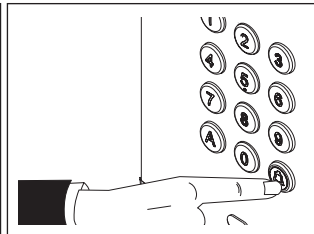
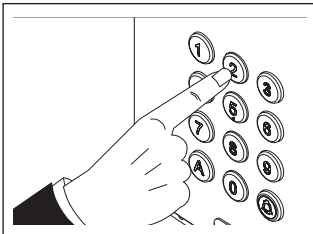
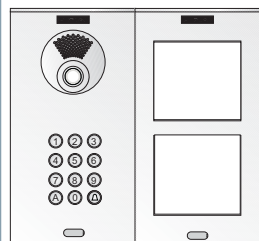

**Keypad panels (Direct):** The call to the apartment is placed by entering the “call code/call direction” that has been assigned to each apartment terminal, using a numerical keypad which also has an access control function.

Call: apartment number + 

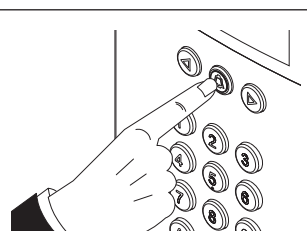
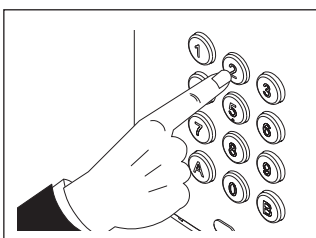

**Outdoor panels with keypad and electronic directory (Digital with extra display):** The call to the apartment is placed by entering the “call code/call direction” that has been assigned to each apartment terminal, using a numerical keypad which also has an access control function.

Call: apartment number + 

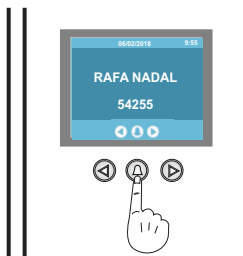
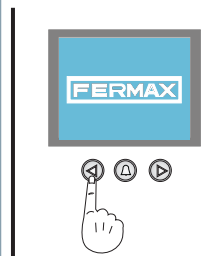

Digital Panels with extra display include an electronic directory which enables users to search for names using the incorporated display and to call the apartment of the name that has been searched for by pressing the “bell” key.

*Note: In the digital panels and pushbutton panels, the “call code/call direction” can be reprogrammed (mapped call). Mapped call: Mapping is an advanced programming option which enables the modification of the call code that has been inherently assigned by the system for another different call code in order to cover all of the coding requirements. See subsection 2.2 Advanced Programming.*

- Call reception.

The call code sent through the bus is received by all of the terminals in the installation but it is only recognised by the apartment terminal (or terminals) that have been programmed with this same code, generating the call ring tone in the apartment and the activation of the video function (in terminals with video).

*Note: The exception is when multi-channel regenerators are used in blocks and these will only allow the calls corresponding to their block to pass. See sub-section 6.3 DUOX 1S multi-channel regenerator (ref. 3259).*

- Communication and door release.

When the apartment terminal receives the call (its address matches the call code generated by the amplifier), a direct connection is established between the terminal that is being called and the outdoor panel/guard unit from which the call has been made.

Upon pick-up or the establishment of communication in the terminal (depending on the model), audio/video communication will be established between the terminal and the outdoor panel/guard unit.

This communication is limited to a maximum time of 90 seconds (once this time has elapsed, communication is cut) and a minimum time of 15 seconds (during which time no call requests from the outdoor panel or the auto-switch on from other terminals are attended).

It is also possible to establish communication with the outdoor panel without a previous call using the auto switch-on function which is available in audio and video terminals, (*see section 7. Apartment Terminals*). During the communication interval, it is possible to release the door using the pushbutton that has been enabled for this purpose in the apartment terminal.

- Completion of communication: Hang-up/Closing of the audio channel (depending on the terminal model). Once the maximum communication time has elapsed or the apartment terminal has hung up/closed the audio channel, the system will return to standby mode.

- Activation commands.

The DUOX system incorporates pushbuttons F1 and F2 (depending on the models) in its apartment terminals. These enable the activation of external devices such as the DUOX relay for the management of additional features such as courtesy lights, secondary foods, garages and so on. (*See sub-section 8. DUOX Relay*).

## 1.5 CALL CODIFICATION

The DUOX system uses 6-digit apartment terminal addresses [000001 - 999999]. This provides a great deal of flexibility in terms of being able to number the terminals in accordance with the conventions of each country.

The digits of the call code are arranged as follows:

### BBSSNN:

- **BB** indicates the **block number (00..99)**.

Apartments per block: Maximum 9999.

- **SS** indicates the **sub-block number (00..99)**.

Apartments per sub-block: Maximum 99.

A sub-block is a part of a block which may be worth sub-dividing for organisational purposes. A sub-block may be a building, a floor of a building or an area of a condominium made up of villas.

- **NN** indicates **the apartment number in the sub-block (01..99)**.

This can range from 01 to 99.

It is not necessary to divide the installation based on this hierarchy as the system can be adapted to the requirements of the installation.

The **outdoor panels** can be configured in the following form:

- General Entrance [G]. Enables a call range of 000001 to 999999.
- Block entrance [B]. Enables a call range of 0001 to 9999.
- Sub-block entrance [S]. Enables a call range of 01 to 99.

Each outdoor panel may also have a different number in each block, sub-block or general entrance, which will range in value from 0 to 9. The default setting is a value of 0.

For further details *see sub-section 1.5.2 Examples of the configuration of outdoor panels and apartment terminals*.

### 1.5.1 PLACING A CALL BASED ON THE CONFIGURATION OF THE OUTDOOR PANEL

The type of outdoor panel will determine how the call is made and how the call code is generated. For DUOX, the range is [000001-999999]. It is important to remember that depending on the type of outdoor panel, it may not be necessary to enter all of the digits when placing the call:

- General Entrance: 6 digits are used to place calls.

*Note: The exception is when call mapping is made and used and when there are zeros to the left. See Examples of the configuration of outdoor panels and apartment terminals in sub-section 1.5.2.*

- Block entrance: The last 4 digits are used to place calls. (The amplifier autocompletes the first two digits with the number of the block to be called).
- Sub-block entrance: the last 2 digits are used to place calls. (The amplifier autocompletes the first two digits with the number of the block and the two following digits with the number of the sub-block to be called).

- Outdoor panel configured as General Entrance  
General Entrance, telephone range BBSSNN (000001 to 999999).

**Example:** Making a call from an outdoor panel in the General Entrance to **Apartment 2** of **Block 4**.

When placing the call, the code to enter is: **4 00 02**

The call code generated by the outdoor panel: **04 00 02**

Notes:

- If a code with an unexpectedly short length is entered, this is filled with '0' on the left hand side, meaning that there is no need to enter **Block 04**, only **Block 4**
- The amplifiers of the outdoor panels are configured as sub-block 00 by default.

- If the Outdoor Panel has been configured as Block it will only allow the call to the Block (BB) that has been configured.

**Example:** Placing a call from an outdoor panel configured as **Block 25** to **Apartment 2**.

When placing the call, the code to enter is: **2**

The call code generated by the outdoor panel: **25 00 02**

Notes:

- **Block Entrance:** The last 4 digits are used to place calls. (The amplifier autocompletes the first two digits with the number of the block to be called)
- If a code with an unexpectedly short length is entered, this is filled with '0' on the left hand side, meaning that there is no need to enter: **Sub-block 00 Apartment 02** -> **00 02**, only **2**.
- The amplifiers of the outdoor panels are configured as sub-block 00 by default.

- If the Outdoor Panel has been configured as Block + Sub-Block it will only allow the call to the Block (BB) and to the Sub-Block (SS) that have been configured.

**Example:** Placing a call from an outdoor panel configured as **Block 12** and Sub-Block 03 of **Apartment 6**.

When placing the call, the code to enter is: **6**

The call code generated by the outdoor panel: **12 03 06**

Notes:

- **Sub-block entrance:** the last 2 digits are used to place calls. (The amplifier autocompletes the first two digits with the number of the block and the two following digits with the number of the sub-block to be called).
- If a code with an unexpectedly short length is entered, this is filled with '0' on the left hand side, meaning that there is no need to enter: **Apartment 06**, only **Apartment 6**.

## 1.5.2 EXAMPLES OF THE CONFIGURATION OF OUTDOOR PANELS AND APARTMENT TERMINALS

At the back of the amplifier of the outdoor panel there is a **Label** which can be used to list programming information.

It is highly advisable to fill in the fields of the label which correspond to the programming made, in case it is necessary to extend the installation at a later date or in case the device fails and it is necessary to substitute it with a new one.

TYPE	N°
<input type="checkbox"/> EG	
<input type="checkbox"/> BK	
<input type="checkbox"/> SB	BK
N°PL	

The next pages will outline the following examples:

- 1) General Entrance with 2 Direct Outdoor Panels to 3 Internal Blocks with 1 Pushbutton Panel and 18 Apartments in each one of these.. 6 digits are used to place calls from the general entrance.
- 2) General Entrance with 2 Digital Outdoor Panels with Extra Display to 3 Internal Blocks with 1 Direct Outdoor Panel and 18 Apartments in each one of these. 3 digits are used when placing the call because mapping is made from the digital outdoor panels of the general entrance.
- 3) General Entrance with 2 Digital Outdoor Panels with Extra Display to 2 Internal Blocks with 1 Direct Outdoor Panel and 18 Apartments in each one of these. 6 digits are used to place calls from the general entrance.
- 4) General Entrance with 2 Direct Outdoor Panels to 6 Villas (Internal Blocks of 1 Apartment), with 1 single-line Pushbutton Panel in each one of these. 6 digits are used to place calls from the general entrance.
- 5) General Entrance with 2 Direct Panels to 2 Internal Blocks. On each floor of each internal block, 1 single-line outdoor panel per apartment configured as a Sub-Block. 6 digits are used to place calls from the general entrance. The number of the Sub-Block is the same throughout the internal block and it is necessary to map the pushbuttons of the single-line panels.
- 6) General Entrance with 2 Direct Panels to 2 Internal Blocks. On each floor of each internal block, 1 single-line outdoor panel per apartment configured as a Sub-Block. 6 digits are used to place calls from the general entrance. The Sub-Block number is different in the internal block and it is not necessary to map the pushbuttons of the single-line panels (Apartment 1).

### Example 1

**INTERNAL BLOCKS**(using a 5-digit call from the EG)

There can be up to **99 Blocks**.

Each Block may have **9999 Apartments**, (in pushbutton panels it is possible to programme the pushbuttons up to address 99).

### DIALLING from the pushbutton panel of the BLOCK

Calls from the Block are placed using the corresponding pushbutton (programmed as 1, 2, 3... 18).

Auto switch-on with Outdoor Panel 0 or 1 of the Block in question and also with Outdoor Panel 0 of the General Entrance. (Selected from the monitor).

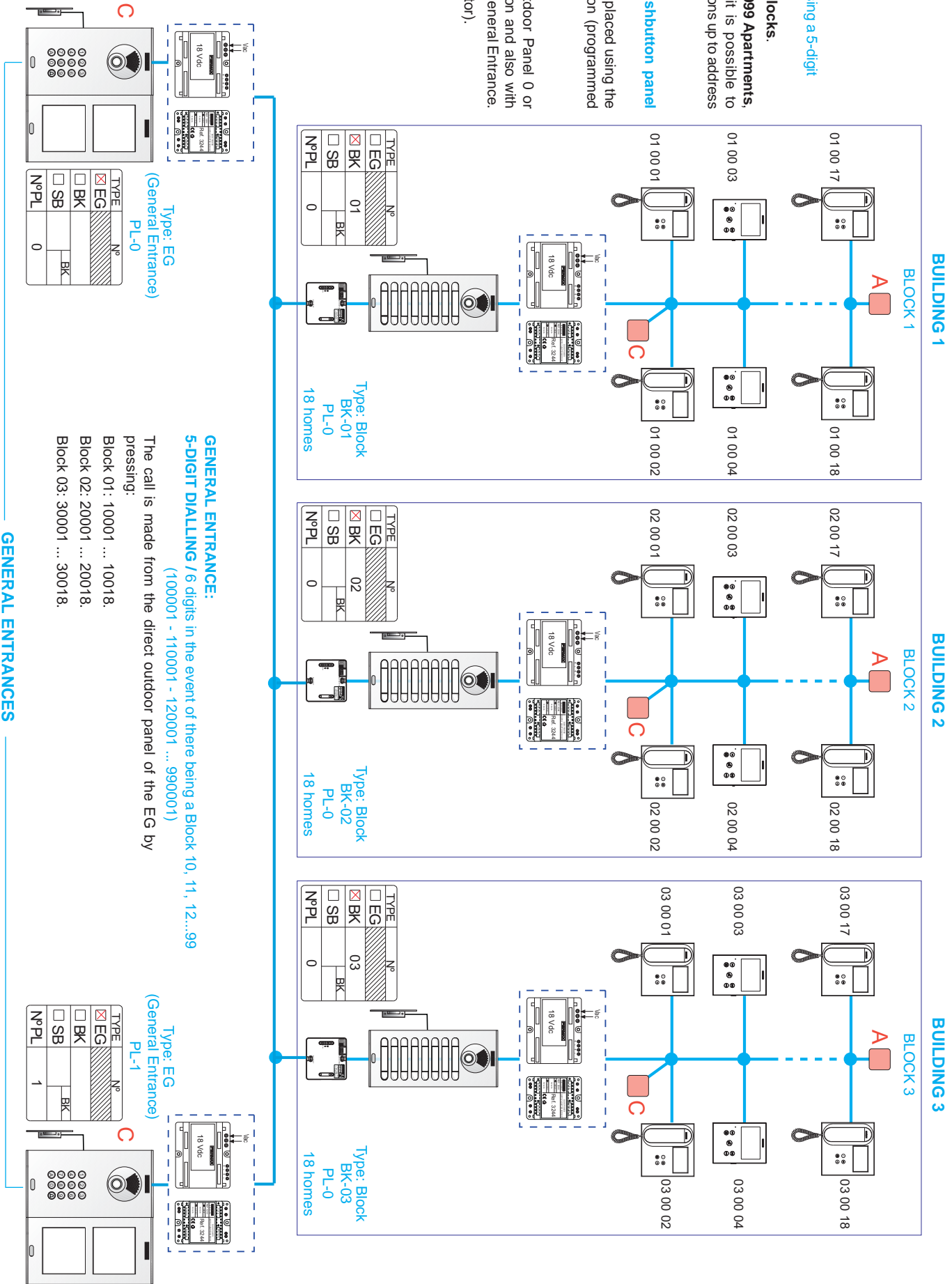

### GENERAL ENTRANCE:

**5-DIGIT DIALLING / 6 digits** in the event of there being a Block 10, 11, 12...99 (100001 - 110001 - 120001 ... 990001)

The call is made from the direct outdoor panel of the EG by pressing:

- Block 01: 10001 ... 10018.
- Block 02: 20001 ... 20018.
- Block 03: 30001 ... 30018.

### GENERAL ENTRANCES

## Example 2

**INTERNAL BLOCKS** (placing a 3-digit call from the EG after having mapped the digital outdoor panels with extra display: 101 - 201 - 301)

There can be up to **99 Blocks**.  
Each block may have up to **99 Apartments**.

**DIALLING from the Direct Outdoor Panel of the Block: 1, 2, 3...18**  
The call from the Block is placed by dialling the Apartment number (1, 2, 3...18).

Auto switch-on with Outdoor Panel 0 or 1 of the Block in question and also with Outdoor Panel 0 of the General Entrance.  
(Selected from the monitor).

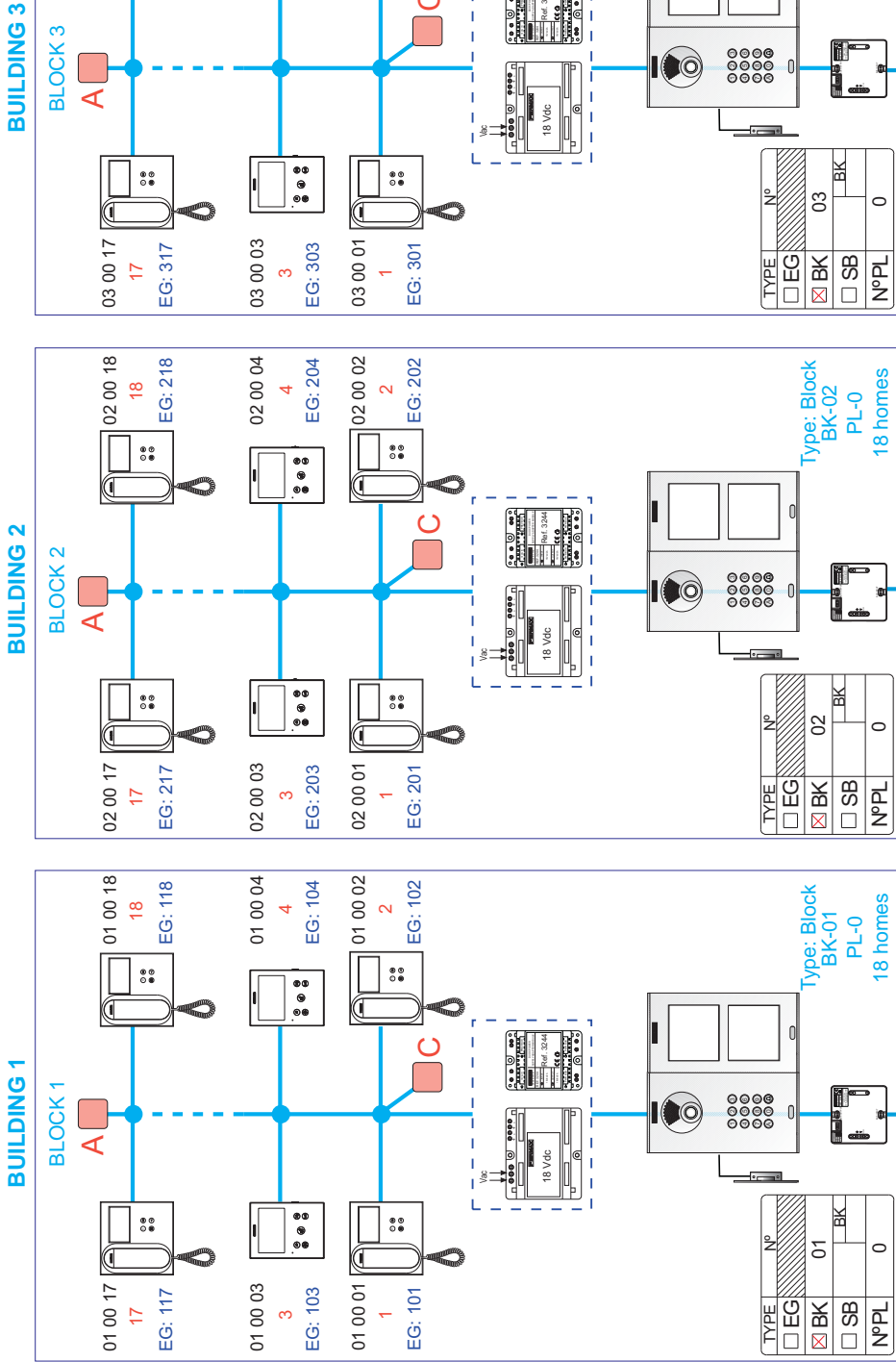

**GENERAL ENTRANCE 3-DIGIT DIALLING / 4 digits in the event that there is a Block 10, 11, 12...99 (1001 - 1101 - 1201 ... 9901)**  
Create the mapping from the Extra Display Digital Outdoor Panel of the General Entrance.

- Mapping 010001 by 101
- Mapping 010002 by 102 and so forth until 010018 per 118
- Mapping 020001 by 201
- Mapping 020002 by 202 and so forth until 010018 per 218
- Mapping 030001 by 301
- Mapping 030002 by 302 and so forth until 010018 per 318

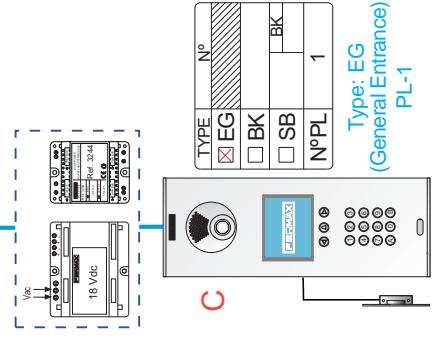
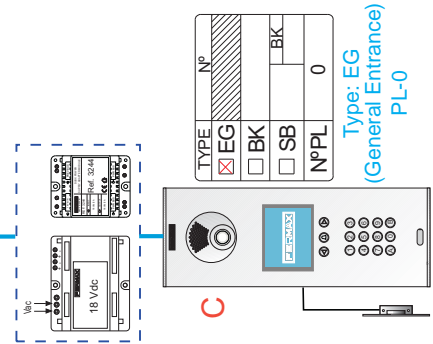

**Example 3**

**INTERNAL BLOCKS** (using a 5-digit call from the EG): 10001 - 20001 - 30001)

There can be up to **99 Blocks**.  
Each block may have up to **9999 Apartments**.

**DIALLING from the Direct Outdoor Panel of the Block: 1, 2, 3...18**

The call can be placed in 2 ways:

- Dialling 5 digits as when calling from the EG:
- \* 10001 ... 10018
- \* 20001 ... 20018
- \* 30001 ... 30018
- Dialling the number of the apartment (1, 2, 3...18).

Auto switch-on with Outdoor Panel 0 or 1 of the Block in question and also with Outdoor Panel 0 of the General Entrance. (Selected from the monitor).

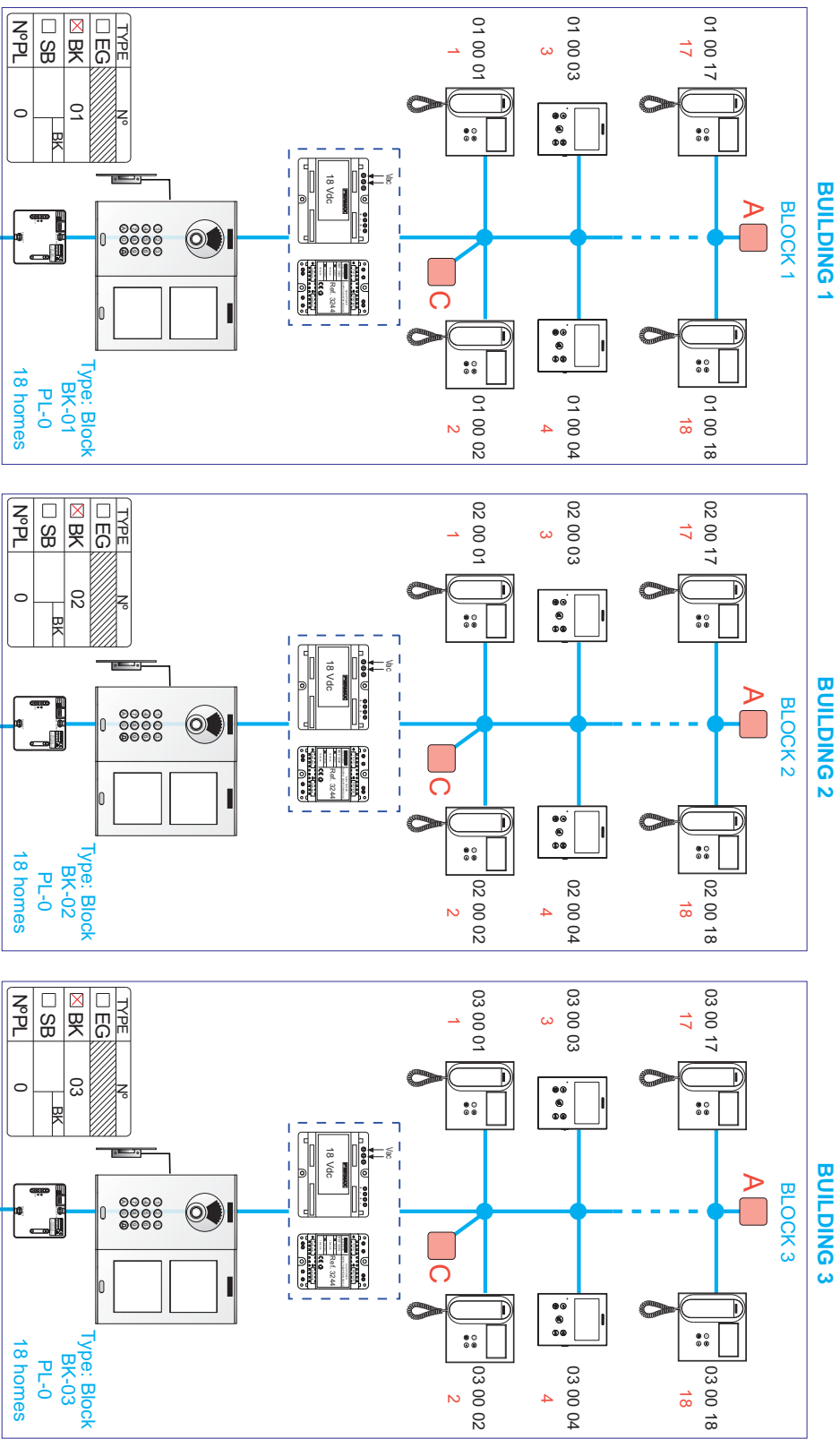

**GENERAL ENTRANCE**  
**5-DIGIT DIALLING / 6 digits in the event of there being a Block 10, 11, 12...99**  
(100001 - 110001 - 120001 ... 990001)

The call is made from the direct outdoor panel of the EG by pressing:

- Block 01: 10001 ... 10018.
- Block 02: 20001 ... 20018.
- Block 03: 30001 ... 30018.

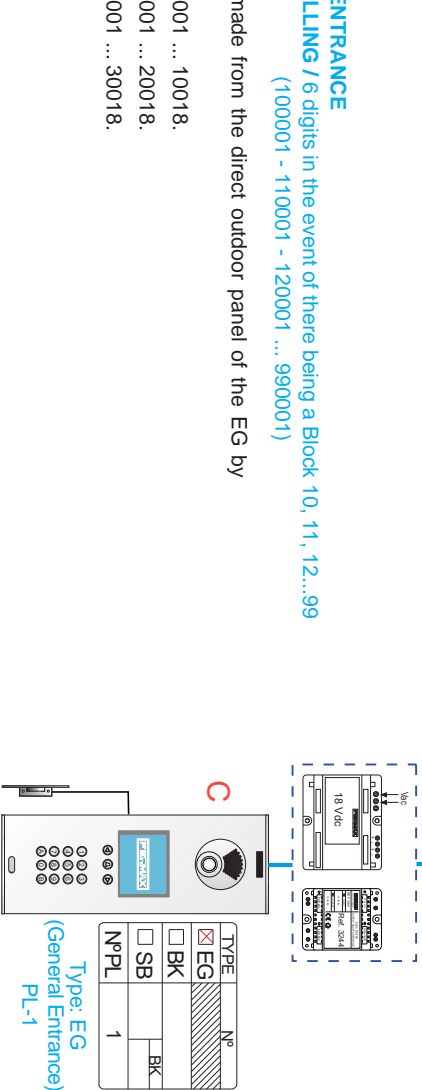
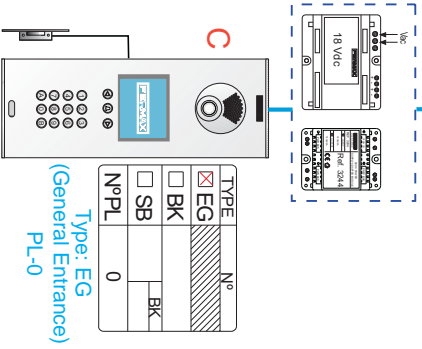

**GENERAL ENTRANCES**



### Example 4

**INTERNAL BLOCKS**(using a 5-digit call from the EG)

There can be up to **99 Blocks**.

Each Block may have up to **9999 Apartments**,

**DIALLING from the pushbutton panel of the BLOCK**

The call is placed using the corresponding pushbutton (programmed as 1).

Auto switch-on with Outdoor Panel 0 or 1 of the Block in question and also with Outdoor Panel 0 of the General Entrance. (Selected from the monitor).

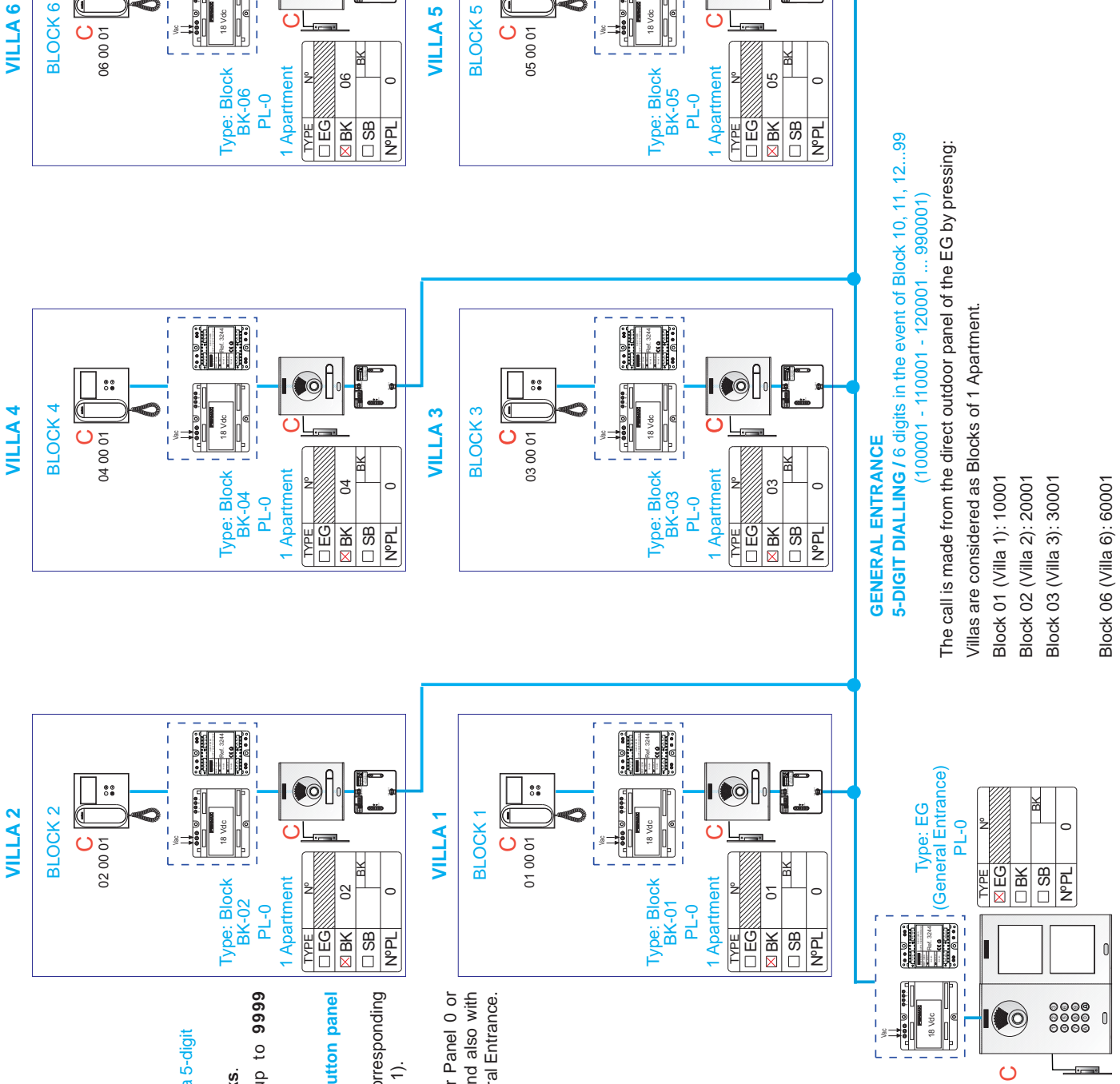

GENERAL ENTRANCES

**Example 5**

**INTERNAL BLOCKS** (using a 5-digit call from the EG): 10001 - 20001)

There can be up to **99 Blocks**.

Each Block may have **9999 Apartments**, (in pushbutton panels it is possible to programme the pushbuttons up to address 99).

**DIALLING from the pushbutton panel of the BLOCK**

Calls from the Block are placed using the corresponding pushbutton (programmed as 1, 2, 3...18).

Each Block may have up to **99 Sub-Blocks**.

On each floor there is one single-line outdoor panel per Apartment, which is programmed as a sub-block outdoor panel.

**DIALLING from the pushbutton panel to the SUB-BLOCK**

The call from the Sub-Block is placed using the pushbutton of the outdoor panel which should be mapped according to the apartment number (2, 3, 4 ... 18). The pushbutton of the outdoor panel of apartment 1 is the only one which corresponds.

As the sub-block number (00) is common to the entire block, it is the numbers of the outdoor panel of the sub-block which change.

**AUTO SWITCH-ON**

Auto switch-on with Outdoor Panel 0 or 1 of the Block in question and also with Outdoor Panel 0 of the General Entrance.

(Selected from the monitor).

There is no Auto Switch-On feature in Sub-Block outdoor panels.

**BUILDING 1**

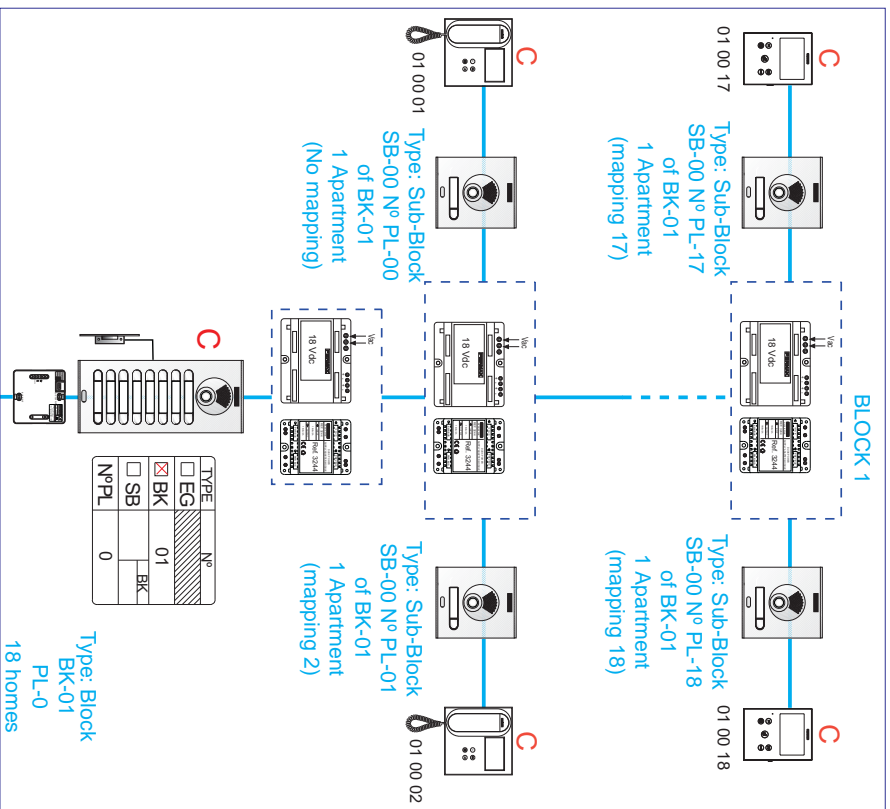

**BUILDING 2**

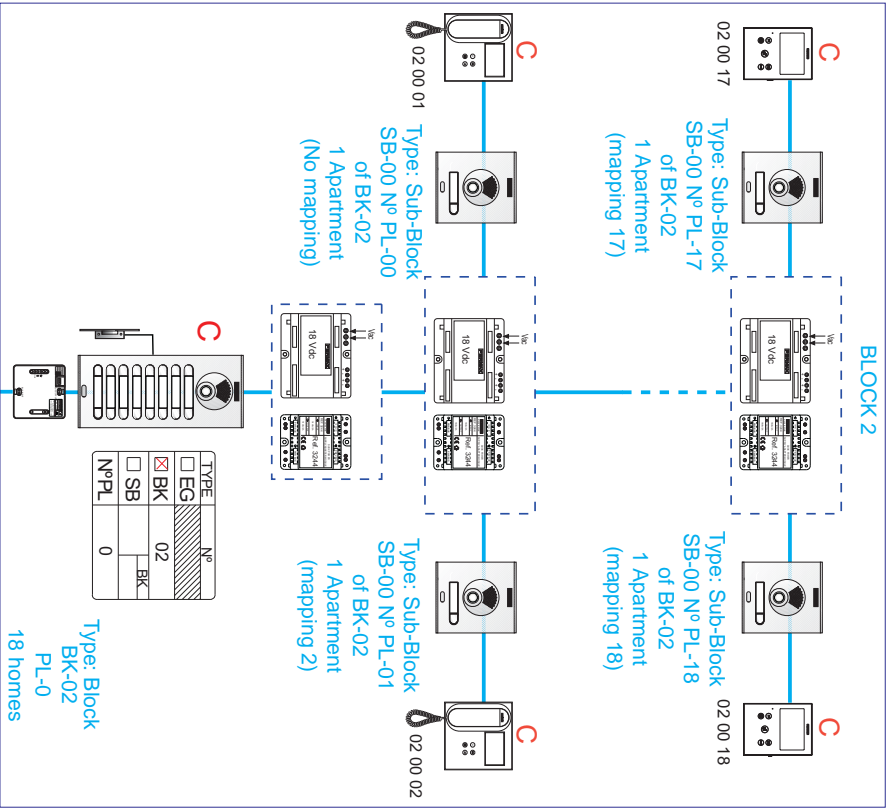

**GENERAL ENTRANCE**

**5-DIGIT DIALLING / 6 digits** in the event of there being a Block 10, 11, 12... 99 (100001 - 110001 - 120001 ... 990001)

The call is made from the direct outdoor panel of the EG by pressing:

Block 01: 10001 ... 10018.

Block 02: 20001 ... 20018.

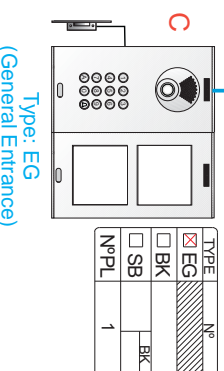
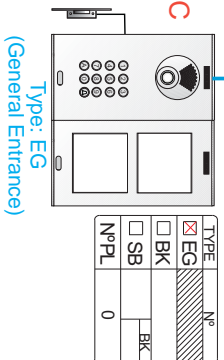

**GENERAL ENTRANCES**

## Example 6

**INTERNAL BLOCKS** (using a 5-digit call from the EG): 10001 - 20001

There can be up to **99 Blocks**.

Each block may have up to **9999 Apartments**.  
**DIALLING from the Direct Outdoor Panel of the Block: Sub-Block + Apartment; 0101, 0201 ...1801**

The call can be placed in 2 ways:

- Dialling 5 digits as when calling from the EG:  
 \* 10101, 10201, 10301 ... 11801  
 \* 20101, 20201, 20301 ... 21801  
 \* 30001 ... 30018

- Dialling the number of the Sub-Block + Apartment (the Block numbers can be omitted): 101, 201 ...1801

On each floor there is one single-line outdoor panel per Apartment, which is programmed as a sub-block outdoor panel.

### DIALLING from the pushbutton panel to the SUB-BLOCK

The call from the Sub-Block is placed using the pushbutton of the outdoor panel (with this type of coding there is no need to map the pushbutton of the outdoor panel). This means that the number of the outdoor panel is the same (00) in the different apartments in the block. What changes are the numbers of the sub-blocks.

### AUTO SWITCH-ON

Auto switch-on with Outdoor Panel 0 or 1 of the Block in question and also with Outdoor Panel 0 of the General Entrance.

(Selected from the monitor).

There is no Auto Switch-On feature in Sub-Block outdoor panels.

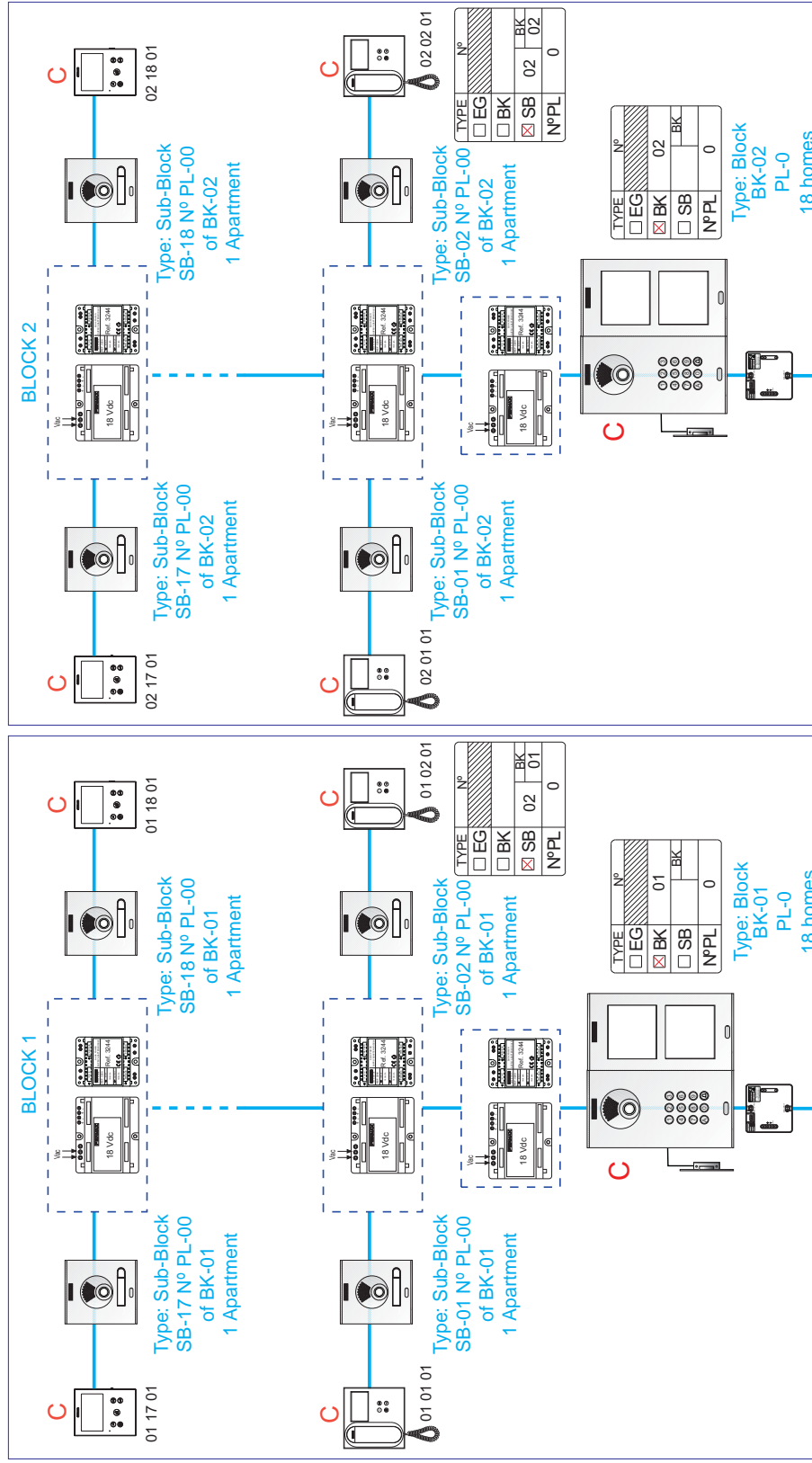

### GENERAL ENTRANCE

**5-DIGIT DIALLING / 6 digits in the event of there being a Block 10, 11, 12...99**  
 (100101 - 110101 - 120101 ... 990101)

The call is placed from the direct outdoor panel of the EG by dialling (Block No. + Sub-Block No. + Apartment No.):

Block 01: 10101, 10201, 10301 ... 11801.

Block 02: 20101, 20201, 10301 ... 21801.

Block 99: 990101, 990201, 990301 ... 991801.

### GENERAL ENTRANCES

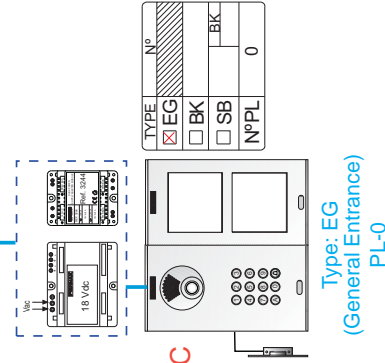

## 2. DUOX OUTDOOR PANELS.

All of the DUOX video door panels include a video amplifier with a highly sensitive wide-angle camera incorporating a focus regulation system as standard. The audio amplifier is incorporated in the audio door panels.

The amplifier manages all of the functions of an installation (calling, communication in both directions, door release, programming and so on).

These are available in all of the FERMAX styles: Cityline, Skyline and Marine.

Depending on their function (the way in which they make the call) and the intrinsic specifications of the model, the outdoor panels may be: Pushbuttons, Direct or Digital.

The digital outdoor panels incorporate a high-brightness 3.5" EXTRA DISPLAY for outdoor environments, which aids usage and boosts the outdoor panel's possibilities.

The DUOX amplifier incorporates a voice-guided programming system which facilitates the configuration and commissioning of the installation in the pushbutton panels. It also includes a voice synthesiser as standard. When actuated, the lock release issues the message: "Door open. Please close after entering".

Outdoor panels with different aesthetics:

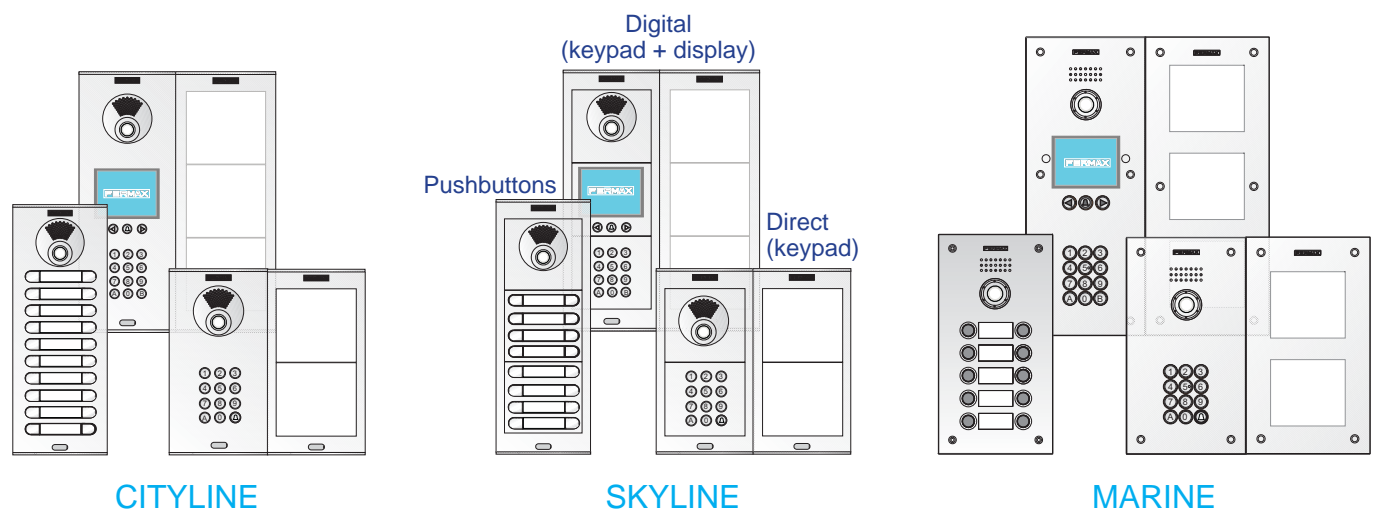

### 2.1 DUOX AMPLIFIERS

Several different DUOX amplifier models are included in the outdoor panels depending on the type of panel. Regardless of the outdoor panel model, they are compatible with one another and can therefore coexist within the same installation.

Amplifier models and outdoor panels in which they are included:

#### 2.1.1 Video Amplifier for Cityline and Marine Outdoor Panels with Pushbuttons

- \* Cityline Video Outdoor Panels with Pushbuttons.
- \* Marine Video Outdoor Panels with Pushbuttons.

#### 2.1.2 Video Amplifier for Skyline, Direct and Digital Outdoor Panels.

- \* Skyline Video Outdoor Panels: with Pushbuttons, Direct and Digital.
- \* Cityline Video Outdoor Panels: Direct and Digital.
- \* Marine Video Outdoor Panels: Direct and Digital.

#### 2.1.3 Audio Amplifier for Cityline and Marine Outdoor Panels with Pushbuttons

- \* Cityline Audio Outdoor Panels with Pushbuttons.
- \* Marine Audio Outdoor Panels with Pushbuttons.

#### 2.1.4 Audio Amplifier for Skyline, Direct and Digital Outdoor Panels.

- \* Skyline Audio Outdoor Panels: with Pushbuttons, Direct and Digital.
- \* Cityline Audio Outdoor Panels: Direct and Digital.
- \* Marine Audio Outdoor Panels: Direct and Digital.

2.1.1 VIDEO AMPLIFIER FOR CITYLINE AND MARINE OUTDOOR PANELS WITH PUSHBUTTONS

a) SETTINGS

1a) Outdoor panel settings

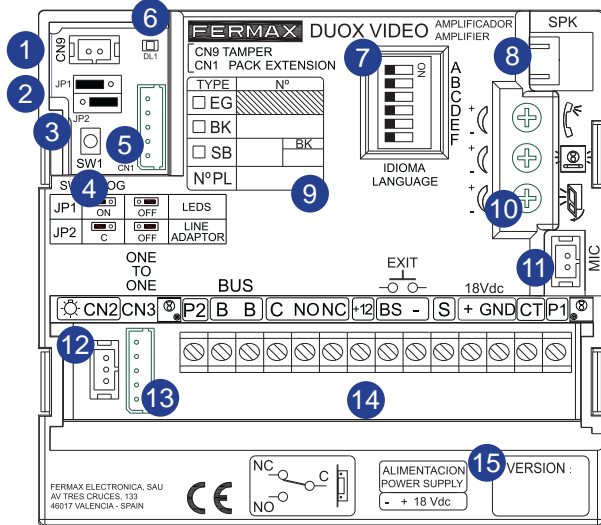

- 1 CN9: TAMPER connection
- 2 JP1: Camera LEDs  
LEDS ON. switched on when the camera is activated.  
LEDS OFF. always switched off.
- 3 JP2: Line adapter  
Integrated in the amplifier for potential use.
- 4 SW1 button
- 5 CN1 (5 pins)  
Connection of the call extension module.
- 6 DL1: Status LED  
Intermittent slow blinking. Inverse or Sequential Programming (mapping).  
Shut down. Standby.
- 7 Language selection<sup>1</sup>  
of the "door open" message.
- 8 SPK: Loudspeaker connection
- 9 Programming details label
- 10 Audio settings  
of the Monitor/Telephones, the outdoor panel and the open door.
- 11 Microphone connection
- 12 CN2: Individual pushbutton connection (Cityline outdoor panel)
- 13 CN3: OneToOne module connection
- 14 Outdoor Panel Connectors:  
B,B: DUOX Bus: power supply to telephones/monitors/ data, audio and video.  
C, NO, NC: relay contacts, 2A@30Vdc (lock release connection).  
+12: output 12 Vdc-250mA (maximum 500mA for 100 sec.).  
BS, -: egress pushbutton, (exit button).  
S, -: door sensor input.  
+, GND: not available. Later versions.  
P1, P2: connection to pushbuttons integrated in the amplifier of the Cityline outdoor panel.
- 15 Amplifier version

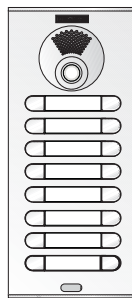
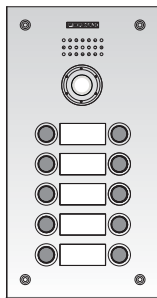

<sup>1</sup>Door open warning language selection

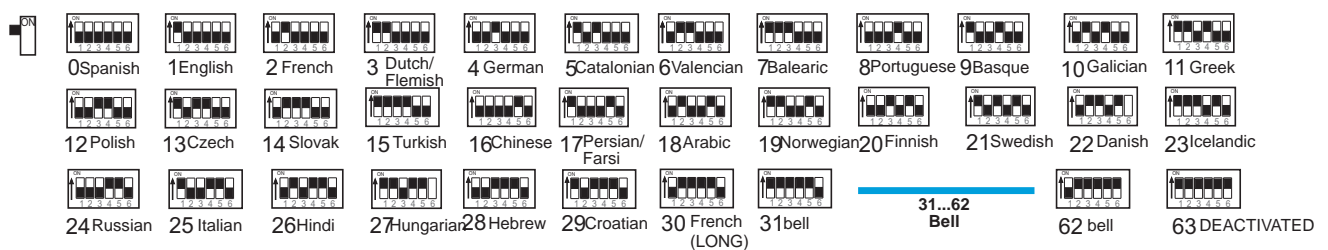

2a) Configuration as master outdoor panel

Required in the event that it is necessary to program the apartment terminal.

**Press button SW1** 3 times in quick succession. Once 2 seconds have elapsed, a confirmation tone will sound and the master outdoor panel will be activated. Once the programming of the monitors/telephones is complete, it is advisable to deactivate the master outdoor panel by **pressing button SW1** 3 times in quick succession.

*Note: When an outdoor panel is configured as master, this will advise the rest of the outdoor panels which are connected in the installation and if a different outdoor panel has previously been configured as master, it will then cease to be configured as such.*

3a) Outdoor panel coding\*

Whenever there is more than one outdoor panel, it will be necessary to program the number of outdoor panels.

4a) Camera focus / Lock release activation time\*

This adjusts the camera image or adjusts the door opening time.

*\*Note: Check sub-section 2b) Voice-assisted configuration in pushbutton panels.*

## 5a) Technical specifications of the amplifier

Power supply	18 Vdc
Standby consumption	165mA
Maximum active audio consumption	480mA
Audio power in the apartment-outdoor panel direction	1 W
Audio power in the outdoor panel-apartment direction	0.15 W
Operating temperature	[-25° , +55°C] / [-13° , 131°F]
Volume adjustable in both directions	
Video	
Resolution	QVGA (320x240) pixels
Sensor	1/3" CMOS colour
Effective number of pixels	1M
Minimum exterior lighting 0.5 lux	
S/N relation	>40dB
Picture refresh	= 25 fps
Auto iris	
Automatic backlighting setting	
Vision angle	90° H, 70°V
Vision in night colour with white LEDs	

## 6a) Outdoor panel amplifier parameters

Lock release activation time	01...99 sec. (by default: 03)
Exit button activation time	00...99 sec. (by default: 06) / (deactivated: 00)
Maximum conversation time	90 sec.
Type of outdoor panel	sub-block/block/general entrance. (by default: block)
Block Number	00..99, (by default: 00)
Sub-Block Number	00..99, (by default: 00)
Outdoor Panel Number	0..9, (by default: 0)
Door sensor time	000..250, (by default: 000, non-active)
Volume monitoring	0..9, (by default: 5)
Non-active MASTER outdoor panel	
Mapping	
Sequential programming time of pushbuttons following halt of activity	60 sec.
Inverse programming time of pushbuttons following halt of activity	300 sec.

**b) CONFIGURATION**

The DUOX amplifier includes "Restore" and "Change Value" functions which enable users to restore/change the parameters that have been programmed.

## 1b) Reset of the mapping of the call code of the pushbuttons

In order to reset the mapping that has been made:

- Remove the power supply.
- Press the SW1 programming button to supply power to the amplifier and hold this button down for 5 seconds. You should hear a "beep" sound. The Led (DL1) will blink rapidly to indicate that the restore process has taken place.

*Note: This mapping reset function is for all of the outdoor panels with PUSHBUTTONS regardless of the aesthetic design:*

- Cityline outdoor panels
- Marine outdoor panels
- Skyline outdoor panels

2b) Voice-assisted configuration in pushbutton panels

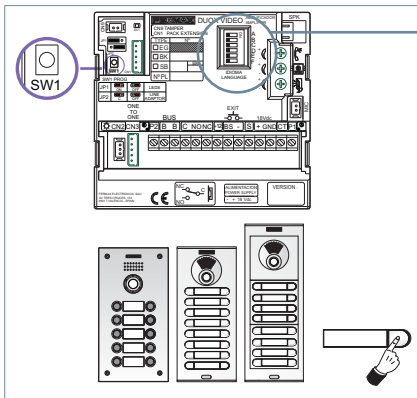

Selection of the language of voice messages by means of the **Synthesiser**. (Languages available: Spanish, English, French, German, Italian and Portuguese).

Note: Voice-assisted configuration is for all of the outdoor panels with **PUSHBUTTONS** regardless of the aesthetic design:

- Cityline outdoor panels
- Marine outdoor panels
- Skyline outdoor panels

1. Access the configuration by pressing SW1 4 times in a row. The amplifier will reproduce the "CONFIGURATION" message and will initiate the process.

In order to exit the configuration process you may press and hold SW1 for 5 seconds, or the process will be exited automatically if no activity is detected for 30 seconds.

See diagram.

2. Pressing SW1 will move through the different parameters and will reproduce the following by voice: **parameter and current configured value**.

Once the message has been reproduced, pressing on any call button will modify the value (a BEEP will be heard each time the button is pressed and the value will rise).

Once the entry has been completed it is possible to listen to the reproduction of the new value by allowing 5 seconds to elapse without pressing anything. When the value of the parameter reaches the maximum possible value, a "BOOP" sound will be heard and the value will be situated in the minimum possible of this parameter.

3. Pressing on the call button for 5 seconds will create a "BOOP" sound and the parameter, when this is the selection of a number, will be located at its minimum value and if it is a type of value it will be reset to the default value.

DIAGRAM

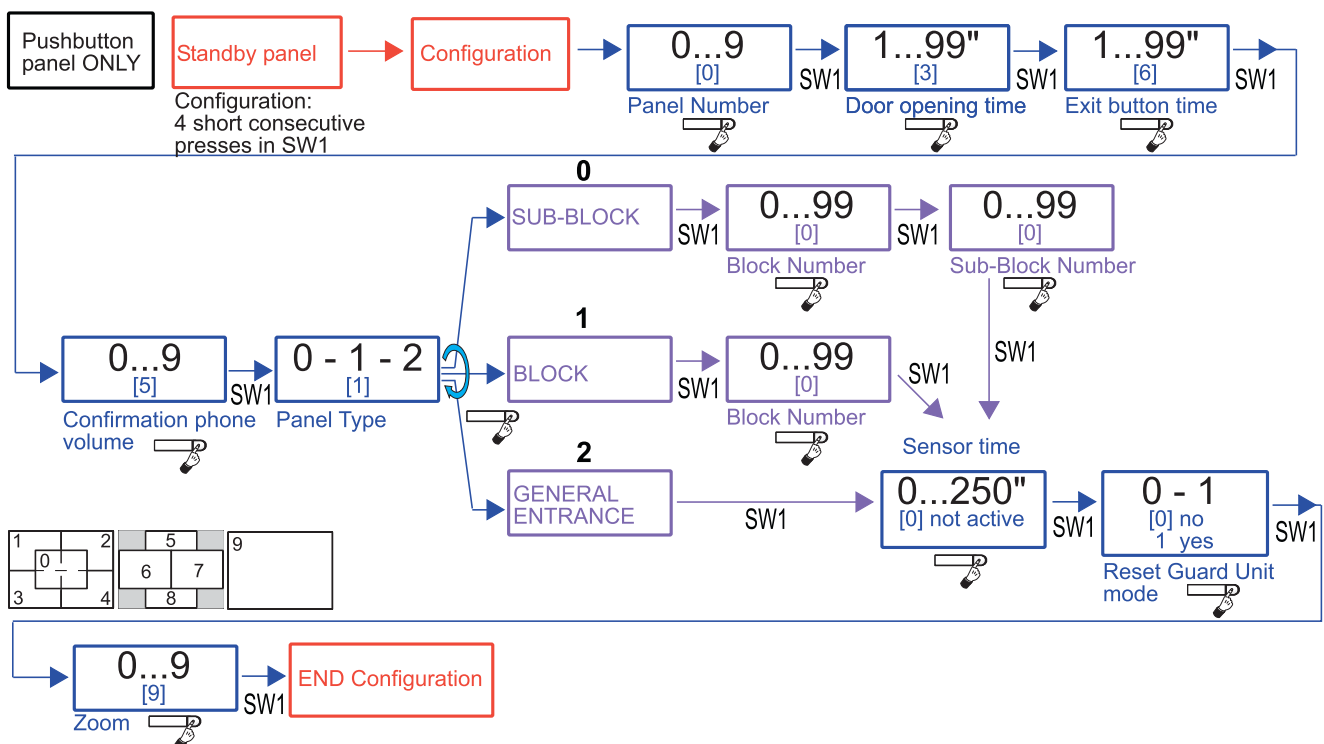

 c) PRE-WIRING

1c) Call extension module

One of the benefits of the DUOX system is the fact that it does not use call wires. This is made possible by the fact that the call is placed through the transmission of a digital code which is generated by the outdoor panel amplifier when a given call button is pressed.

In pushbutton panels (Cityline and Marine), one or more call extension modules are used to generate the specific code for each one of the calls. This module converts the pressing of each button on the outdoor panel into a call code.

The call code that is generated by the pushbutton is determined by the connection from the pushbutton to the call extension module.

There are 2 call extension modules:

- Ref. 2441 16-pushbutton call extension module.
- Ref. 2008 8-pushbutton call extension module.

Cityline kit panels with 1 and 2 pushbuttons

It is only the Cityline kit panels with 1 and 2 pushbuttons that do not require the installation of the call extension module.

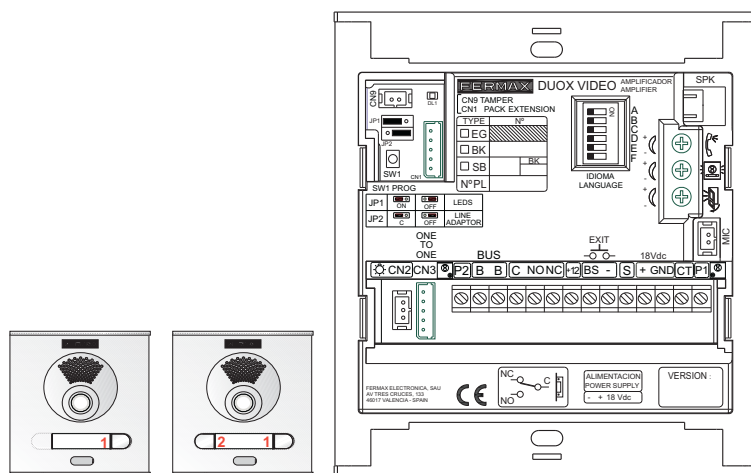

Pre-wiring for Marine kit panels with 1 and 2 pushbuttons with 8-pushbutton call extension module

All of the Marine outdoor panels require the installation of the call extension module, regardless of the number of pushbuttons.

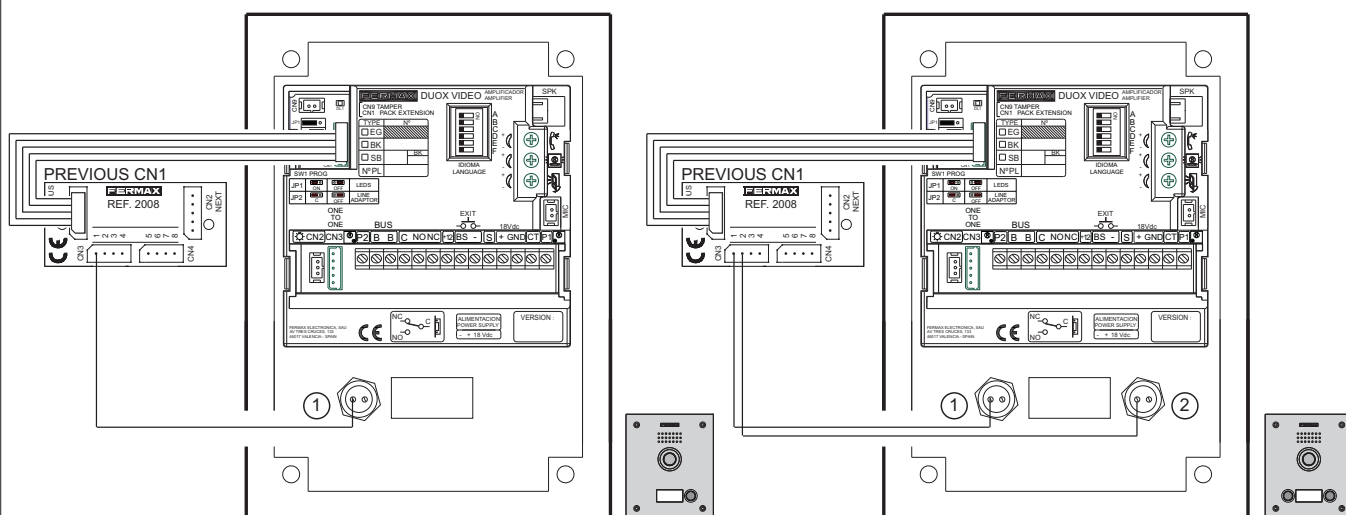



CITYLINE outdoor panel pre-wiring  
 Connection of call extension module Ref. 2441.

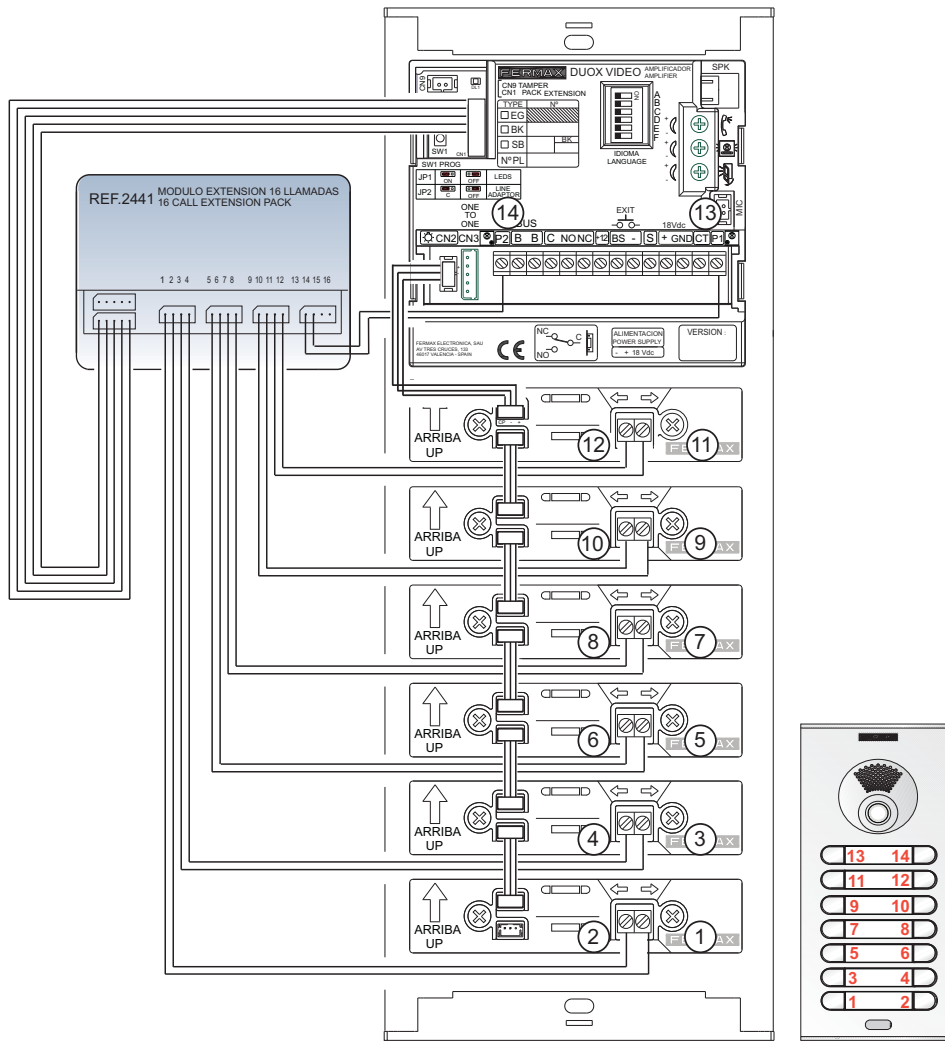

Connection of several call extension modules (more than 16 pushbuttons)

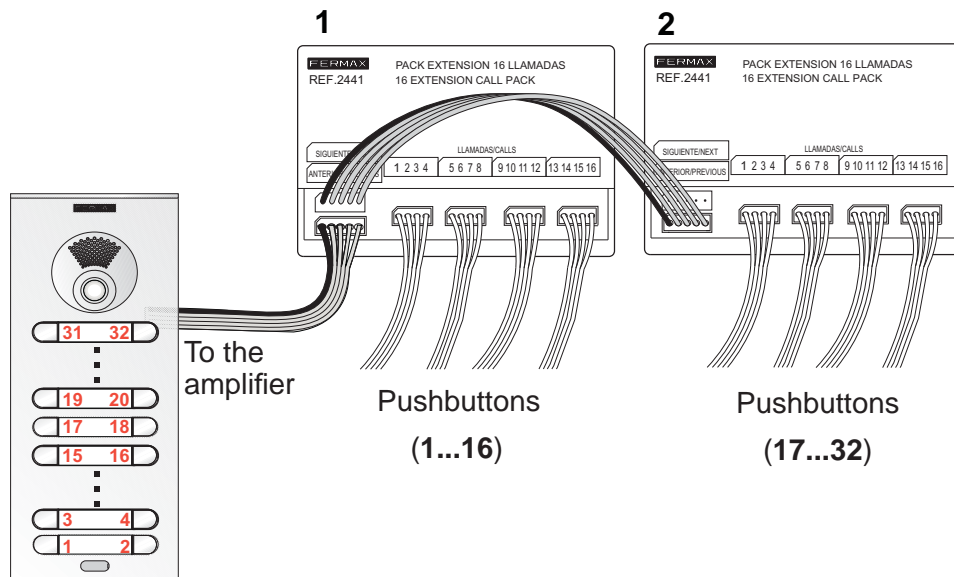

CITYLINE outdoor panel pre-wiring  
 Connection of call extension module Ref. 2008.

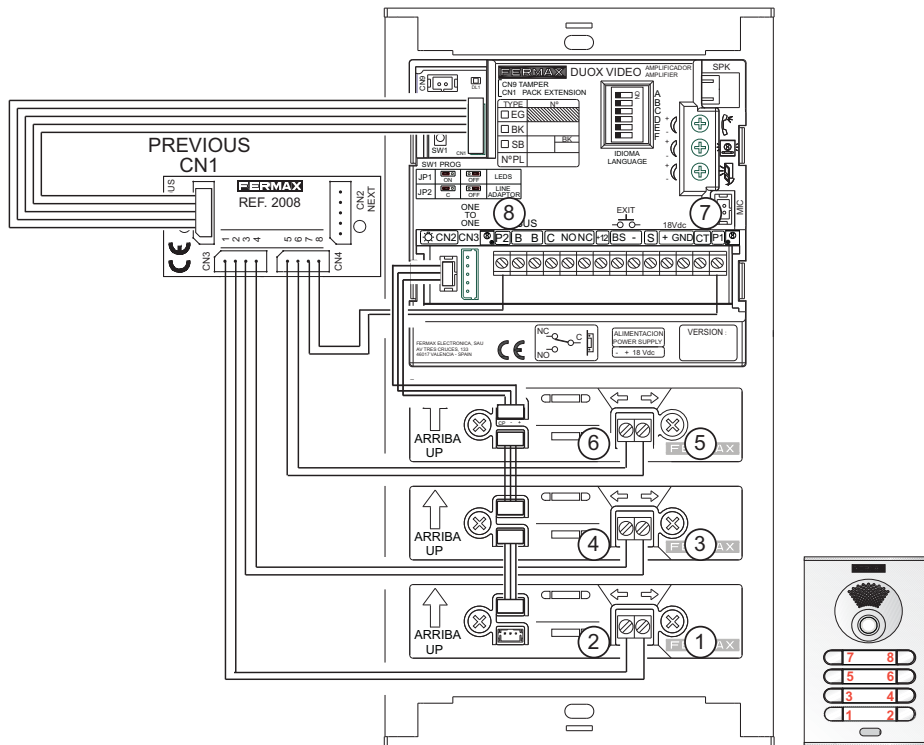

Connection of several call extension modules (more than 8 pushbuttons)

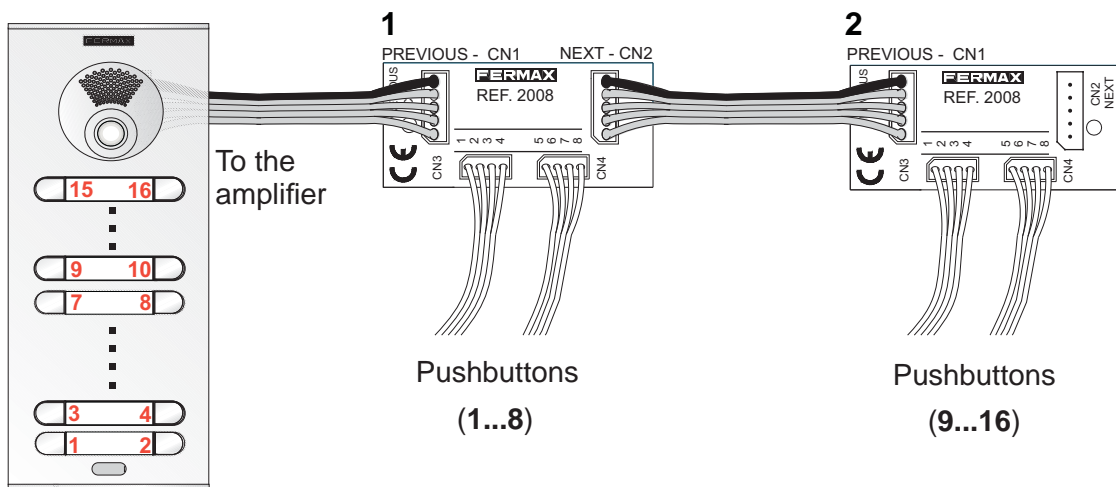

MARINE outdoor panel pre-wiring  
 Connection of call extension module Ref. 2441.

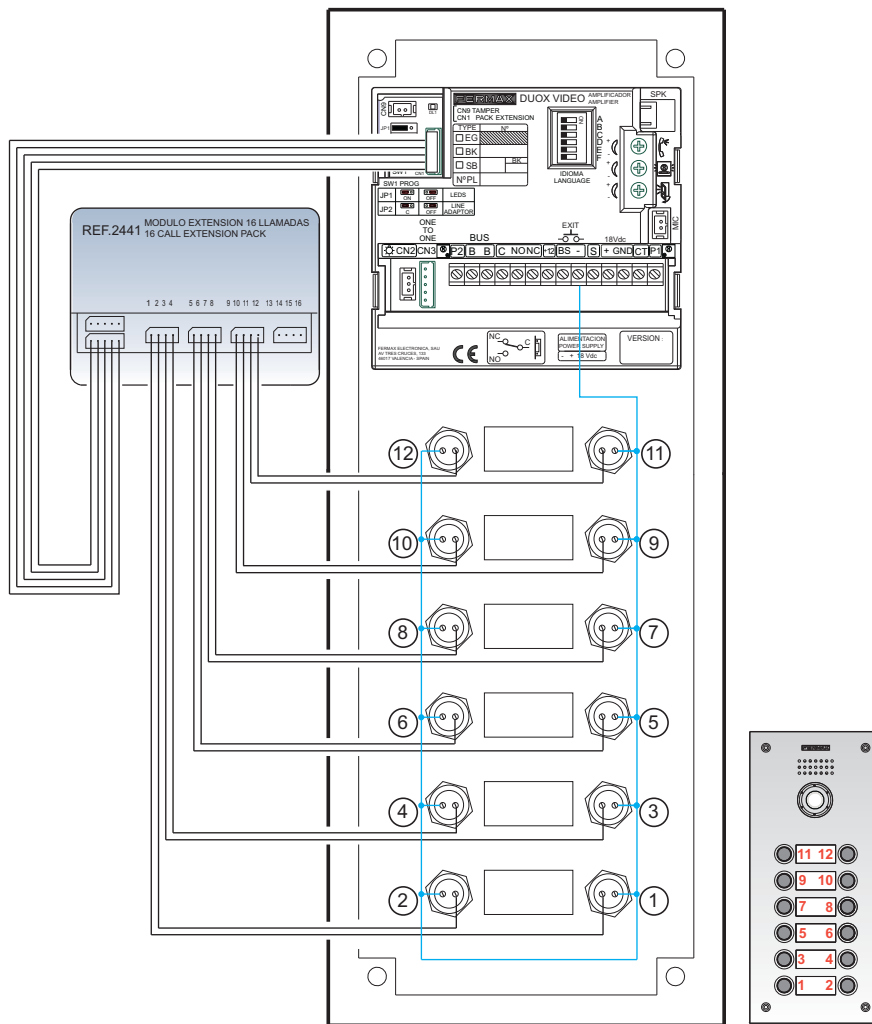

Connection of several call extension modules (more than 16 pushbuttons)

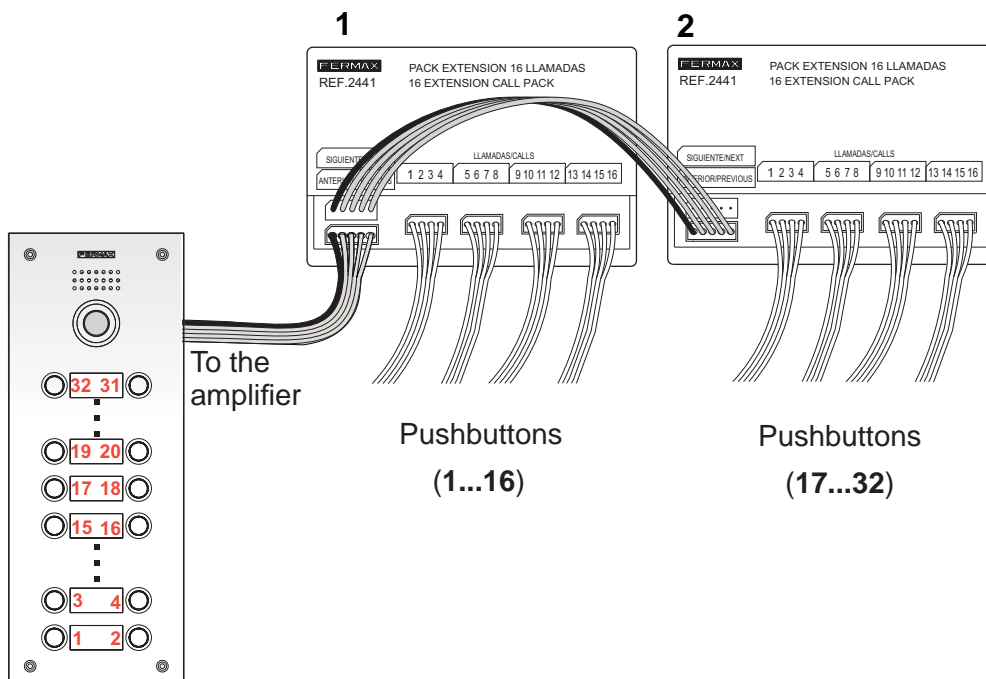

MARINE outdoor panel pre-wiring  
 Connection of call extension module Ref. 2008.

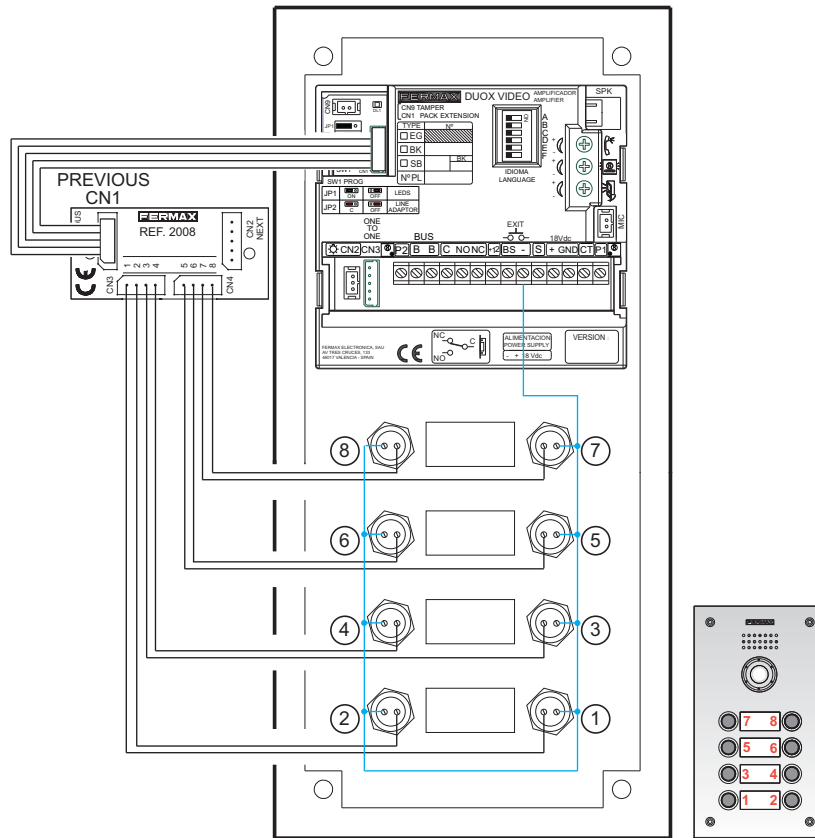

Connection of several call extension modules (more than 8 pushbuttons)

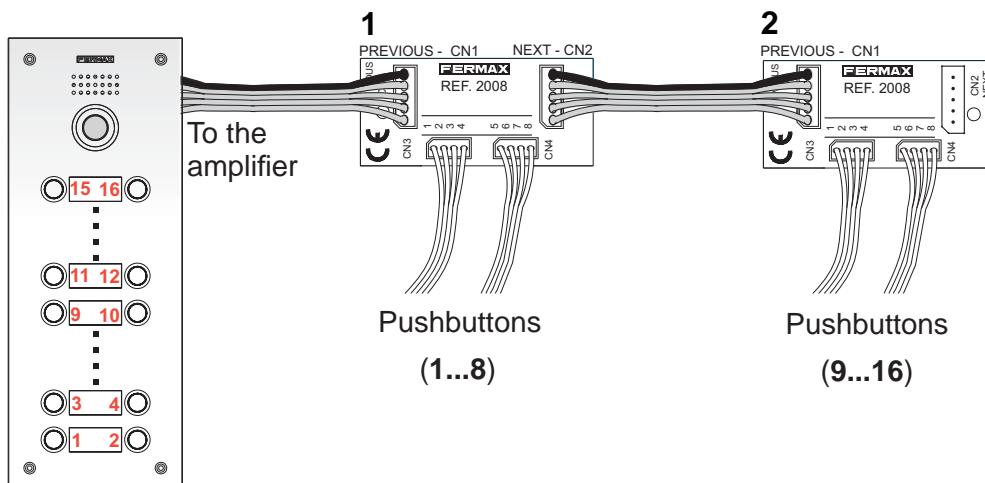

Notes:

- In the event that it is necessary to accommodate a larger amount of pushbuttons, two or more modules may be used, up to the total of the 90 apartments that enable the DUOX system in pushbutton panels.
- The assignment of call codes by the call extension module may be modified using the "Mapping" function which is available in the DUOX amplifier. See subsection 2.2 Advanced Programming.

## 2.1.2 VIDEO AMPLIFIER FOR SKYLINE, DIRECT AND DIGITAL OUTDOOR PANELS

### a) SETTINGS

#### 1a) Outdoor panel settings

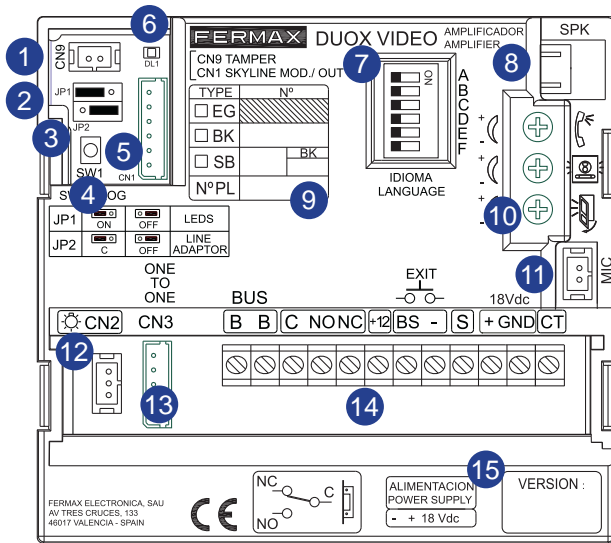

- 1 CN9: TAMPER connection
- 2 JP1: Camera LEDs  
LEDS ON. switched on when the camera is activated.  
LEDS OFF. always switched off.
- 3 JP2: Line adapter  
Integrated in the amplifier for potential use.
- 4 SW1 button
- 5 CN1 (6 pins)  
Connection of modular pushbuttons, keypad and display.
- 6 DL1: Status LED  
Intermittent slow blinking. Inverse or Sequential Programming (mapping of pushbutton panels).  
Shut down. Standby.
- 7 Language selection<sup>1</sup>  
of the "door open" message.
- 8 SPK: Loudspeaker connection
- 9 Programming details label
- 10 Audio settings  
of the Monitor/Telephones, the outdoor panel and the open door.
- 11 Microphone connection
- 12 CN2: Individual pushbutton connection (Cityline outdoor panel)
- 13 CN3: OneToOne module connection
- 14 Outdoor Panel Connectors:  
B,B: DUOX Bus: power supply to telephones/monitors/ data, audio and video.  
C, NO, NC: relay contacts, 2A@30Vdc (lock release connection).  
+12: output 12 Vdc-250mA (maximum 500mA for 100 sec.).  
BS, -: egress pushbutton, (exit button).  
S, -: door sensor input.  
+, GND: not available Later versions.
- 15 Amplifier version

	DIRECT	DIGITAL	PUSH-BUTTONS
CITYLINE			
SKYLINE			
MARINE			

#### <sup>1</sup>Door open<sup>1</sup> warning language selection

#### 2a) Configuration as master outdoor panel

- Pushbutton panels:

Required in the event that it is necessary to program the apartment terminal.

**Press button SW1** 3 times in quick succession. Once 2 seconds have elapsed, a confirmation tone will sound and the master outdoor panel will be activated. Once the programming of the monitors/ telephones is complete, it is advisable to deactivate the master outdoor panel by **pressing button SW1** 3 times in quick succession.

*Note: When an outdoor panel is configured as master, this will advise the rest of the outdoor panels which are connected in the installation and if a different outdoor panel has previously been configured as master, it will then cease to be configured as such.*

- Direct outdoor panels: Check [3b\) Configuration table in direct outdoor panels \(subsequent pages\)](#).

- Digital outdoor panels: Check [4b\) Basic configurations of the extra display \(subsequent pages\)](#).

## 3a) Outdoor panel coding\*

Whenever there is more than one outdoor panel, it will be necessary to program the number of outdoor panels.

## 4a) Camera focus / Lock release activation time\*

This adjusts the camera image or adjusts the door opening time.

\*Note: Consult the relevant sub-section for the type of panel in question:

- Pushbutton panel: 2b) Voice-assisted configuration in pushbutton panels (previous pages).
- Direct outdoor panel: 3b) Configuration table in direct outdoor panels (subsequent pages).
- Digital outdoor panel: 4b) Basic configurations of the extra display (subsequent pages).

## 5a) Technical specifications of the amplifier

Power supply	18 Vdc
Standby consumption	165mA
Maximum active audio consumption	480mA
Audio power in the apartment-outdoor panel direction	1 W
Audio power in the outdoor panel-apartment direction	0,15 W
Operating temperature	[-25° , +55°C] / [-13° , 131°F]
Volume adjustable in both directions	
Video	
Resolution	QVGA (320x240) pixels
Sensor	1/3" CMOS colour
Effective number of pixels	1M
Minimum exterior lighting 0.5 lux	
S/N relation	>40dB
Picture refresh	= 25 fps
Auto iris	
Automatic backlighting setting	
Vision angle	90° H, 70°V
Vision in night colour with white LEDs	

## 6a) Outdoor panel amplifier parameters

Lock release activation time	01...99 sec. (by default: 03)
Exit button activation time	00...99 sec. (by default: 06) / (deactivated: 00)
Maximum conversation time	90 sec.
Type of outdoor panel	sub-block/block/general entrance. (by default: block)
Block Number	00..99, (by default: 00)
Sub-Block Number	00..99, (by default: 00)
Outdoor Panel Number	0..9, (by default: 0)
Door sensor time	000..250, (by default: 000, non-active)
Volume monitoring	0..9, (by default: 5)
Non-active MASTER outdoor panel	
Mapping (pushbutton panel)	
Sequential programming time of pushbuttons following halt of activity	60 sec.
Inverse programming time of pushbuttons following halt of activity	300 sec.
Programming code (direct outdoor panel)	0000..9999, (by default: 4444)
Opening code (direct outdoor panel)	0000..9999, (by default: non-active)

## b) CONFIGURATION

The DUOX amplifier includes “Restore” and “Change Value” functions which enable users to restore/change the parameters that have been programmed.

### SKYLINE PUSHBUTTON PANEL



1b) Reset of the mapping of the call code of the pushbuttons

2b) Voice-assisted configuration in pushbutton panels

*Note: See chapter 2.1.1 VIDEO AMPLIFIER FOR CITYLINE AND MARINE PANELS WITH PUSHBUTTONS, sub-section b) CONFIGURATION.*

### DIRECT OUTDOOR PANELS

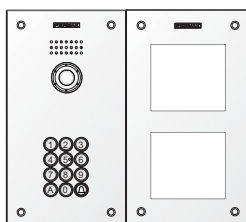
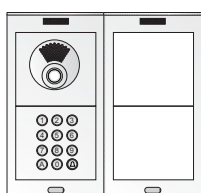

#### 3b) Configuration table in direct outdoor panel

The parameters can be configured using the keypad. In order to do this it is necessary to enter configuration mode using a programming access code after pressing ‘A’.

Entering programming: **A + 4444** (Default programming access code).

If the code is correct, a confirmation tone will sound (beep-beep).

Parameters that may be configured:

Position	Parameter	Setting Values [default]	Commentary
01	Lock release activation time	01-99" [03]	Relay activation of lock release from apartment or access control.
02	Exit button activation time	00-99" [06]	Relay activation of lock release from exit button (terminals <b>Bs</b> and -)
03	Type of outdoor panel	0: Sub-Block [1]: Block 2: General Entrance	Configuration of the type of outdoor panel
04	Block No.	00-99 [00]	Number of the Block which the outdoor panel belongs to
05	Sub-Block No.	00-99 [00]	Number of the Sub-Block which the outdoor panel belongs to
06	Outdoor panel No.	0-9 [0]	Number of the Outdoor Panel
07	Door sensor time	000-250 [000] inactive	Maximum time in which door may remain opened from the opening
08	Opening code	0000-9999 [0000] inactive	Opening code from the keypad. The method of enter the code: A + XXXX (4 digits)
09	Programming Code	0000-9999 [4444]	Programming access code
10	MASTER Outdoor Panel	[0]: No / 1: If	Activation of the outdoor panel as the master for the program. of apart. term.
11	Guard Unit Mode	[0]: No Reset 1: Reset	Reset to night mode by entering “1” in this position
12	Volume Monitoring	0-9 [5]	Set the volume of the outdoor panel monitoring
13	RESET parameters	[0]: No Reset 1: Reset	Recuperate the default values by entering “1” in this position
14	Camera focus	0-9 [9]	The selection of the different 0-9 values represents each one of the video screens

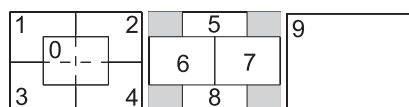

**Configuration of parameters**

Enter the two digits from the position, a “beep” will sound, then enter the chosen value (1, 2, 3 or 4 digits depending on the parameter). If the value is correct, a confirmation tone will sound (beep-beep) and the new value will be saved. If the value is incorrect, the error tone will sound (bop).

**Position + Possible values**

01...14 (beep) 1, 2, 3 or 4 digits (beep-beep)

**Commentary**

Digits based on the parameter chosen

**Examples**

09 (beep) 1128 (beep-beep)

Change of programming code to 1128

01 (beep) 02 (beep-beep)

Change of lock release activation time to 2 seconds

In order to exit the programming, press ‘A’ while entering the menu position number. Programming will also be exited after 60” if no key is pressed, generating a beep-beep tone.

**DIGITAL OUTDOOR PANELS**



**4b) Basic configurations of the extra display**

Different parameters can be configured using the display.. In order to do this it is necessary to enter programming mode.

**ENTER PROGRAMMING MODE**

Press A and enter the access code:  
AB21AB

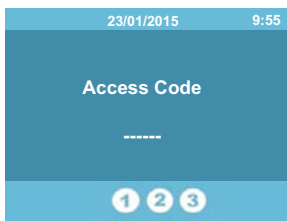

Enter the programming code:  
19025 (by default)



If an incorrect code is entered there will be a revert to standby

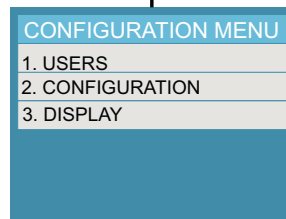

**CONFIGURATION MENU.**

Main options menu. Use the dialling keypad to choose the option desired. Parameters that may be configured::

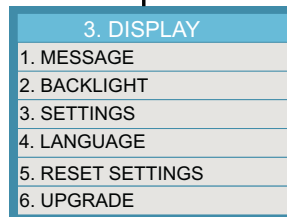
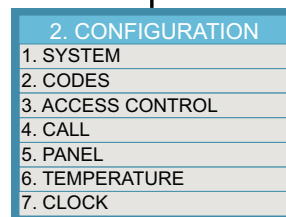
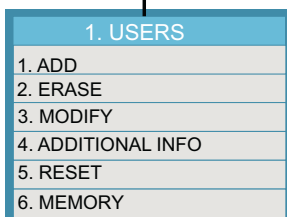

Depending on the **programming code** that has been entered (installer, administrator or concierge code), some of these functions may not appear.

*Note: For more information about the display functions see instructions code. 97869 Quick guide to extra display programming, available on the website.*



**2. CONFIGURATION:** This enables the setting of the parameters of the outdoor panel. Use the numeric keypad to select the desired configuration option.

2. CONFIGURATION	
1. SYSTEM	
2. CODES	
3. ACCESS CONTROL	
4. CALL	
5. PANEL	
6. TEMPERATURE	
7. CLOCK	

3. ACCESS CONTROL	
1. DOOR OPEN TIME	
2. HALL TIME	
3. PROX READER	
4. PIN REQUEST	
5. DOOR SENSOR	

**3. ACCESS CONTROL.**

This option enables the configuration of the parameters relating to the door openings and the access control. Within each option, use the keypad to enter the data and use B to confirm.

1. DOOR OPENING TIME	
03	
Delete	A
Exit	B

Lock release activation time. Activation of the lock release relay from the apartment or the access control.  
*Value settings [default] 01-99" [03].*

2. HALL TIME	
06	
Delete	A
Exit	B

Hall time. Activation of the lock release relay from the exit button (terminalsBs and -).  
*Value settings [default] 00-99" [06].*

5. DOOR SENSOR	
--	
Delete	A
Exit	B

Door sensor time. Maximum time that the door may be open from the door opening.  
*Value settings [default] 000-250" [000] inactive.*

5. PANEL	
1. PANEL NAME	
2. PANEL NUMBER	
3. PANEL TYPE	
4. MASTER	
5. BLOCK	

**5. OUTDOOR PANEL.**

This option enables the configuration of the parameters relating to the panel. Within each of the options, use the arrows as selection tools or use the keypad to enter the data and use B to confirm.

1. PANEL NAME	
EDIFICIO SOL----	
Delete	A
Exit	B

2. PANEL NUMBER	
00	
Delete	A
Exit	B

Outdoor panel number.  
*Value settings [default] 0-9 [0]*

3. PANEL TYPE	
◀ Block Entrance ▶	
Exit	B

Configuration of the type of outdoor panel.  
- General Entrance:  
- Block Entrance (by default).  
- Sub-Block Entrance .

4. MASTER	
◀ Disabled ▶	
Exit	B

Activation of the outdoor panel as the master for the programming of apartment terminals. Once the programming of the monitors/telephones is complete, it is advisable to deactivate the master outdoor panel.

5. BLOCK	
00	
Delete	A
Exit	B

Number of the:  
- Block: 00-99 [00]  
or  
- Sub-Block: 00-99 [00]  
(depending on the type of outdoor panel chosen in option3. **TYPE OF OUTDOOR PANEL**, to which the outdoor panel belongs).

*Note: The camera focus on the digital outdoor panels will take place in the same way as the direct outdoor panels. Convert the digital outdoor panel into a direct outdoor panel by disconnecting the display and connecting the keypad directly to the amplifier until set. See 3b) Configuration table in direct outdoor panels, (previous pages).*

 c) PRE-WIRING

1c) Skyline Outdoor Panels

The DUOX Skyline outdoor panels form the line of continuous profile outdoor panels with modular composition. Assembling the outdoor panel is very simple. Simply select the combination of modules, fit these in position and connect them using the connection cables.

*Note: It is possible to use pushbuttons combined with a keyboard in order to be able to make direct calls to certain apartments (liberal professions), only in digital outdoor panels.*

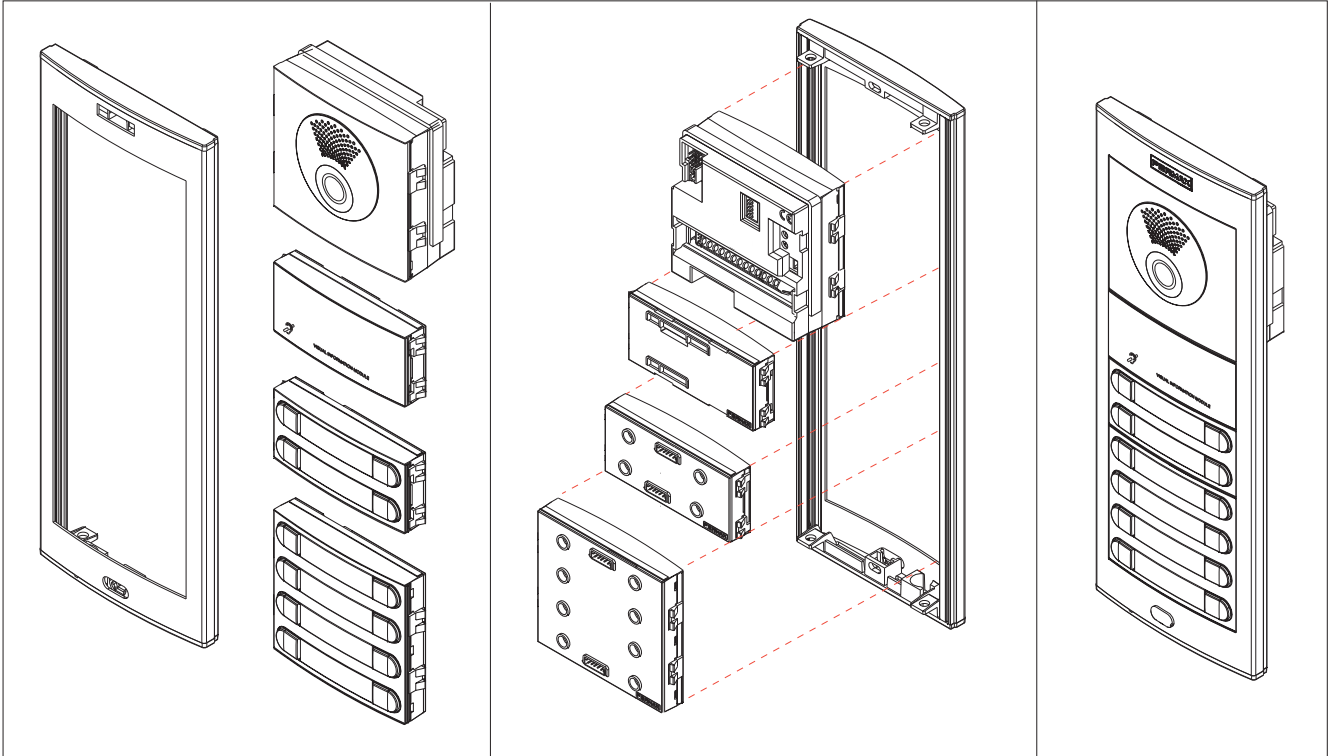

Microphone connection

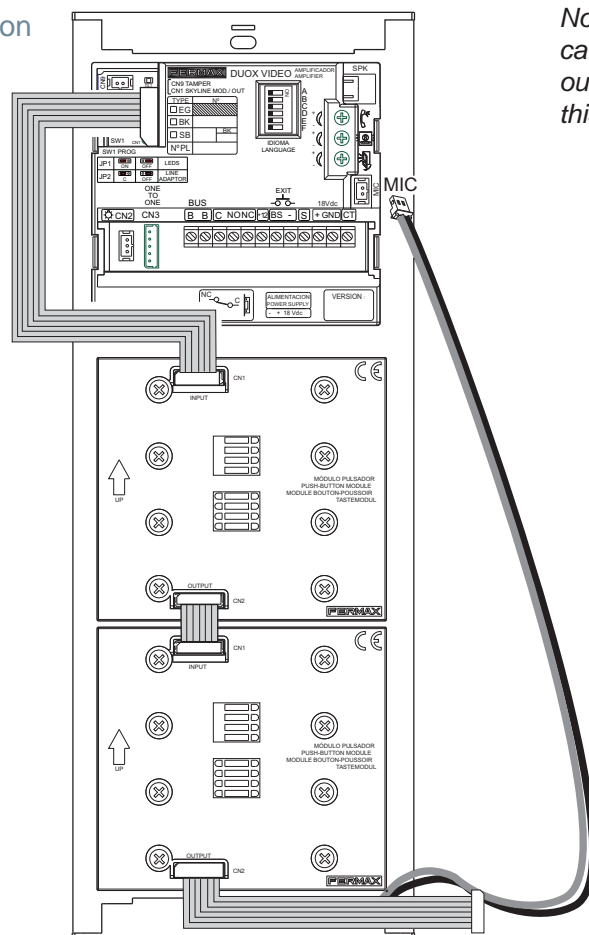

*Note: Do not position the microphone cable inserted along the profile of the outdoor panel. We recommend locating this in the module clippings. See detail.*

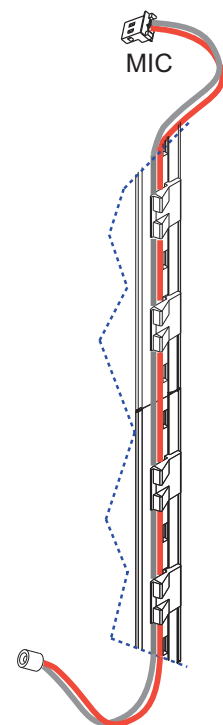

Pre-wiring for PUSHBUTTONS Skyline outdoor panel

The Skyline pushbutton modules do not require call extension modules because these modules include the call code generation feature.

The DUOX amplifier automatically assigns the call codes to the pushbuttons of the connected modules.

The call codes assigned to the pushbuttons can be modified using the mapping function. See subsection 2.2 Advanced Programming.

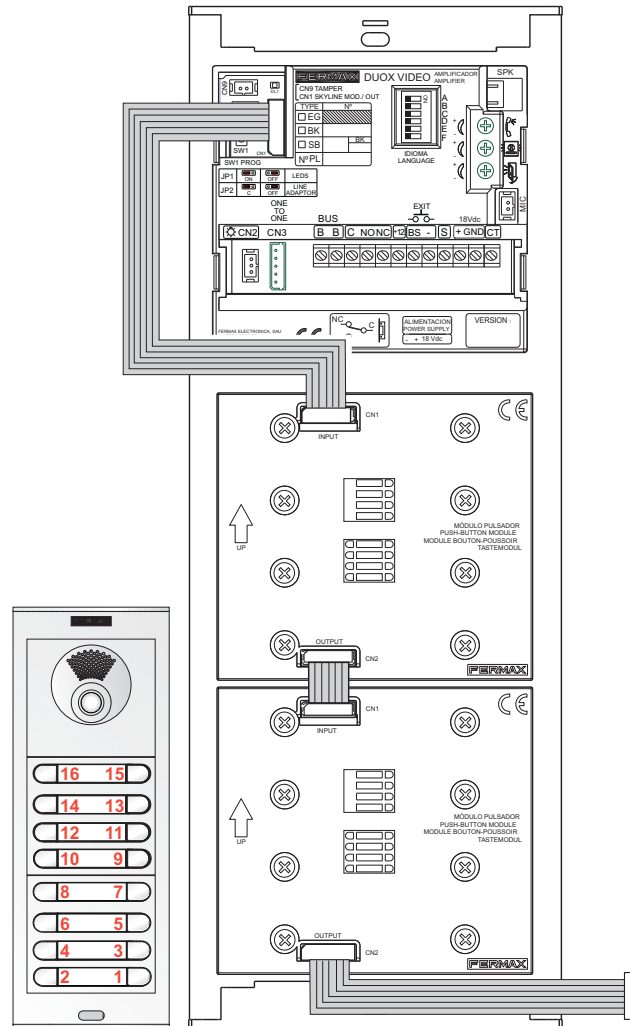

To the following pushbutton module

DUOX addresses assigned by the amplifier

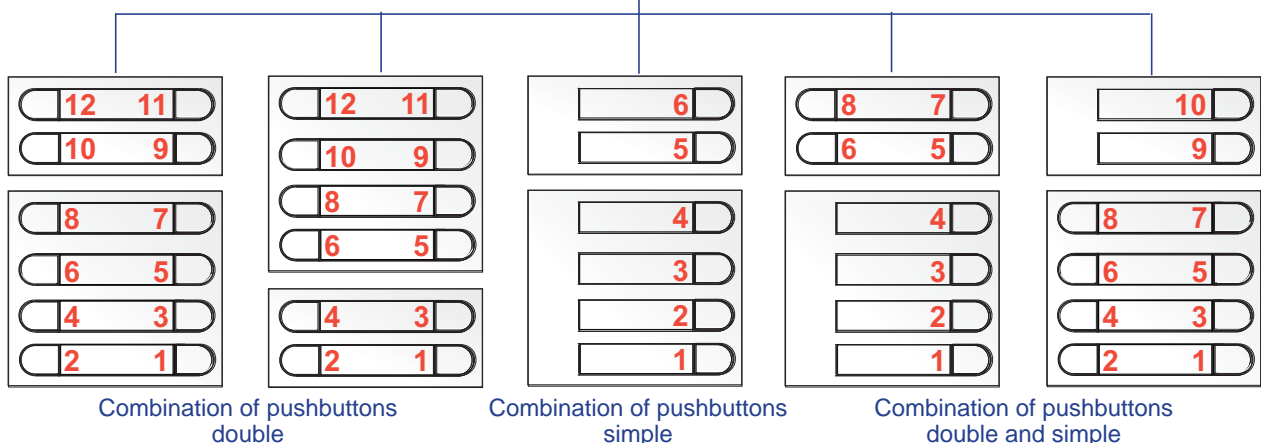

Pre-wiring for DIRECT Skyline outdoor panel

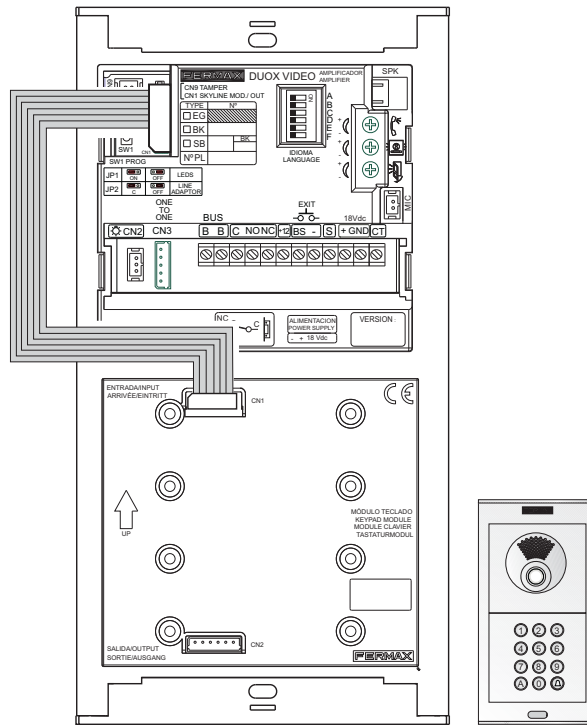

Pre-wiring for DIGITAL Skyline outdoor panel

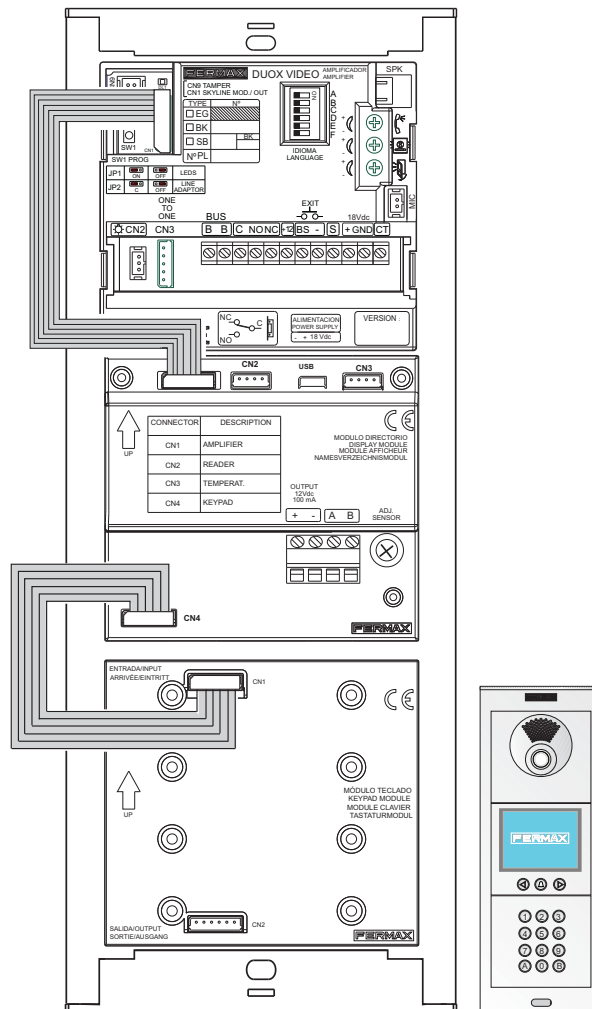

2c) Cityline Outdoor Panels

Pre-wiring for DIRECT Cityline outdoor panel

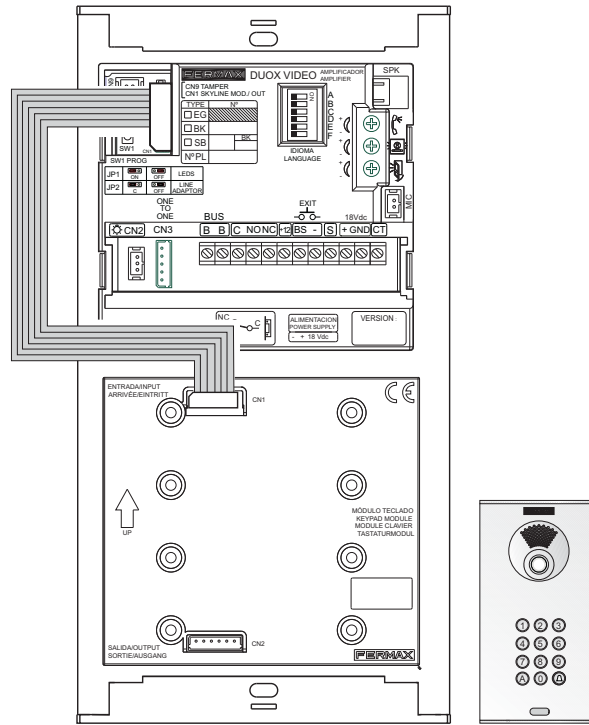

Pre-wiring for DIGITAL City outdoor panel

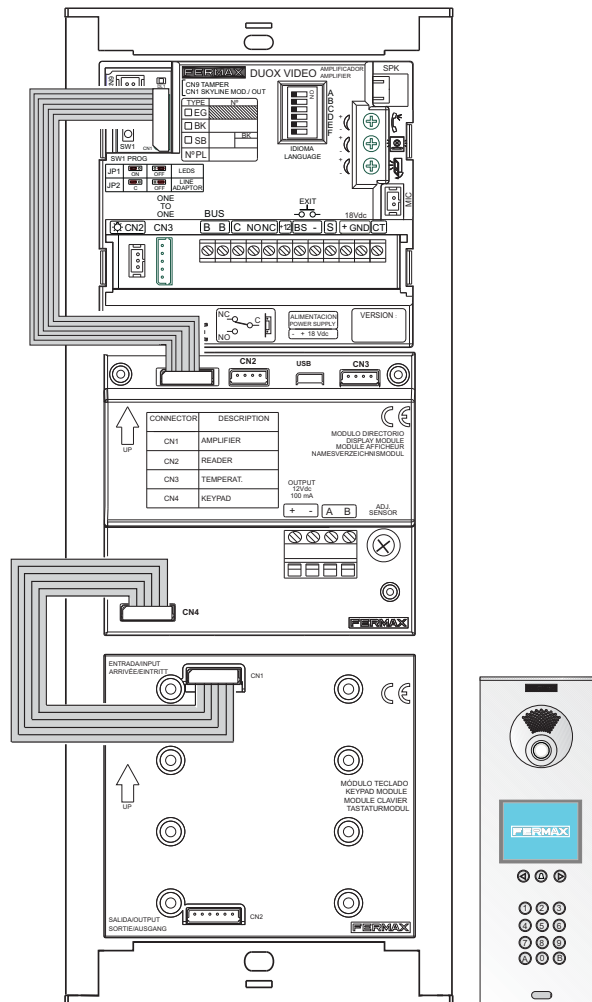

### 3c) Marine Outdoor Panels

#### Pre-wiring for DIRECT Marine outdoor panel

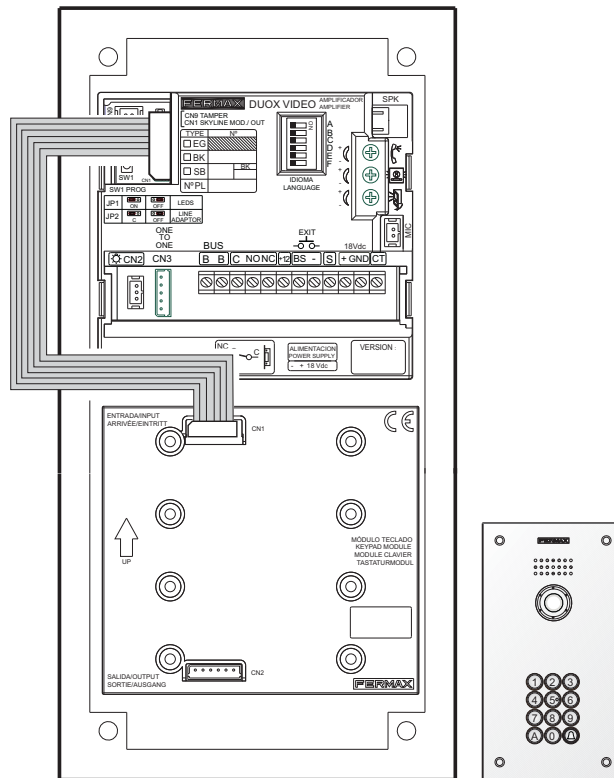

#### Pre-wiring for DIGITAL Marine outdoor panel

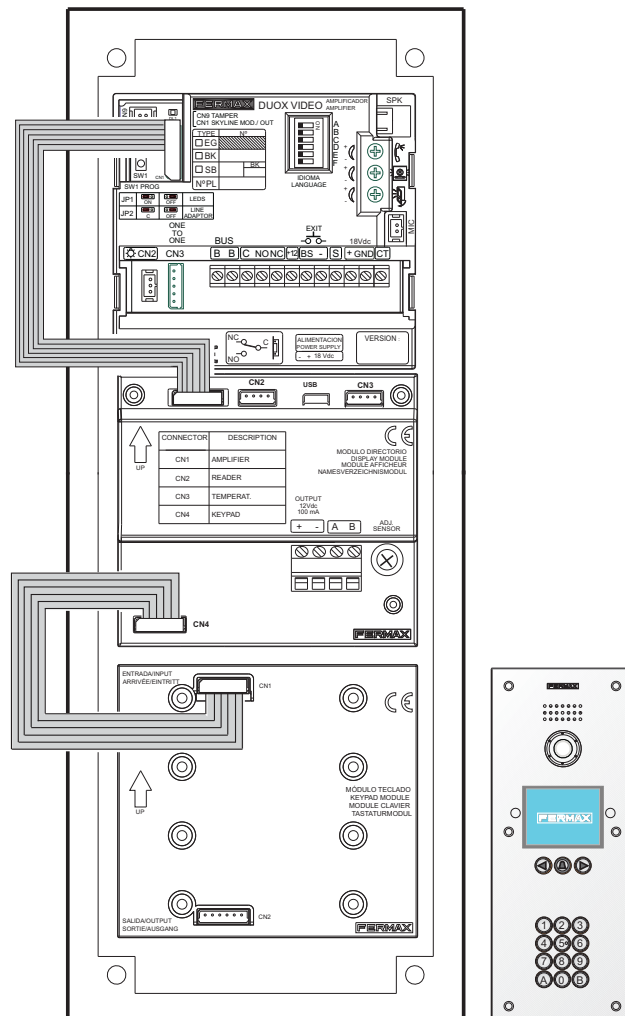

2.1.3 AUDIO AMPLIFIER FOR CITYLINE AND MARINE OUTDOOR PANELS WITH PUSHBUTTONS

a) SETTINGS

1a) Outdoor panel settings

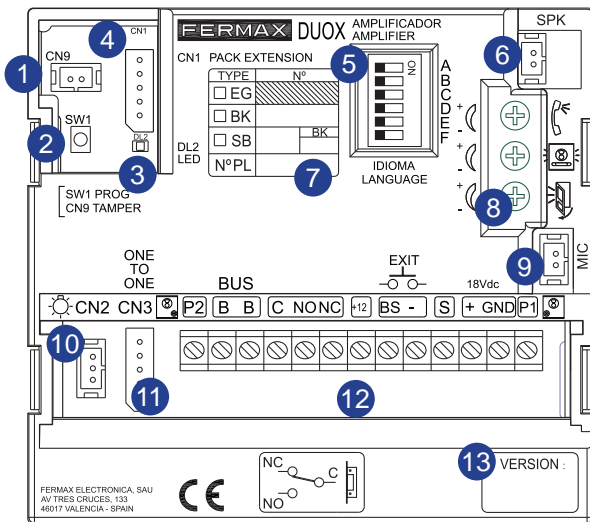

- 1 CN9: TAMPER connection
- 2 SW1 button
- 3 DL2: Status Led
- 3 Intermittent slow blinking. Inverse or Sequential Programming (mapping).  
Shut down. Standby
- 4 CN1 (5 pins)  
Connection of the call extension module.
- 5 Language selection<sup>1</sup>  
of the "door open" message
- 6 SPK: Loudspeaker connection
- 7 Programming details label
- 8 Audio settings  
of the Telephones, the outdoor panel and the open door.
- 9 Microphone connection
- 10 bus(es)  
CN2: μαφιλιφνη βημερηνου συλλεξιου (Cυλιμυ οηφου)
- 11 CN3: OneToOne module connection
- 12 Outdoor Panel Connectors:  
B,B: DUOX Bus: power supply telephones, data and audio.  
C, NO, NC: relay contacts, 2A@30Vdc (lock release connection).  
+12: output 12 Vdc-250mA (maximum 500mA for 100 sec.).  
BS, -: egress pushbutton, (exit button).  
S, -: door sensor input.  
+, GND: not available Later versions.  
P1, P2: connection to pushbuttons integrated in the amplifier of the Cityline outdoor panel.
- 13 Amplifier version

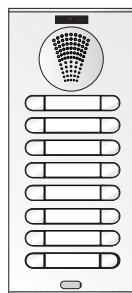
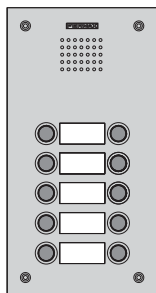

<sup>1</sup>Door open' warning language selection

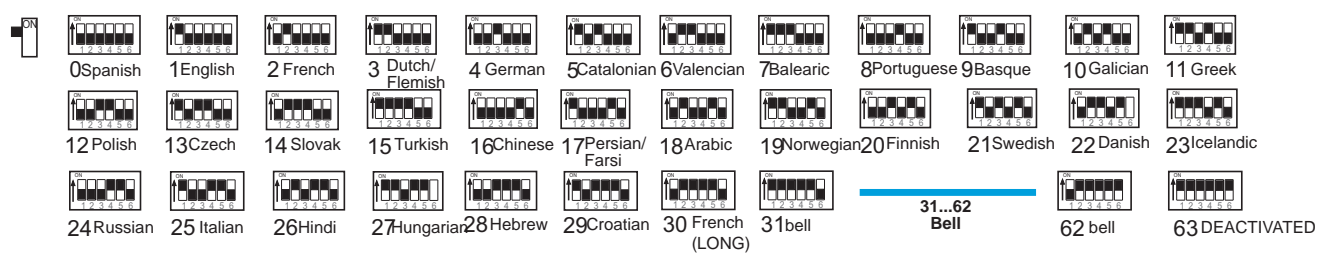

2a) Configuration as master outdoor panel

Required in the event that it is necessary to program the apartment terminal.

**Press button SW1** 3 times in quick succession. Once 2 seconds have elapsed, a confirmation tone will sound and the master outdoor panel will be activated. Once the programming of the telephones is complete, it is advisable to deactivate the master outdoor panel by **pressing button SW1** 3 times in quick succession.

*Note: When an outdoor panel is configured as master, this will advise the rest of the outdoor panels which are connected in the installation and if a different outdoor panel has previously been configured as master, it will then cease to be configured as such.*

3a) Outdoor panel coding\*

Whenever there is more than one outdoor panel, it will be necessary to program the number of outdoor panels.

4a) Lock release activation time\*

Adjusts the door opening time.

*Note: Check sub-section 2b) Voice-assisted configuration in pushbutton panels.*

## 5a) Technical specifications of the amplifier

Power supply	18 Vdc
Standby consumption	94mA
Active audio consumption	550 mA
Audio power in the apartment-outdoor panel direction	1 W
Audio power in the outdoor panel-apartment direction	0,15 W
Operating temperature	[-10° , +60°C] / [-14° , 140°F]
Volume adjustable in both directions	

## 6a) Outdoor panel amplifier parameters

Lock release activation time	01...99 sec. (by default: 03)
Exit button activation time	00...99 sec. (by default: 06) / (deactivated: 00)
Maximum conversation time	90 sec.
Type of outdoor panel	sub-block/block/general entrance. (by default: block)
Block Number	00..99, (by default: 00)
Sub-Block Number	00..99, (by default: 00)
Outdoor Panel Number	0..9, (by default: 0)
Door sensor time	000..250, (by default: 000, non-active)
Volume monitoring	0..9, (by default: 5)
Non-active MASTER outdoor panel	
Mapping	
Sequential programming time of pushbuttons following halt of activity	60 sec.
Inverse programming time of pushbuttons following halt of activity	300 sec.

 b) CONFIGURATION

The DUOX amplifier includes “Restore” and “Change Value” functions which enable users to restore/change the parameters that have been programmed.

## 1b) Reset of the mapping of the call code of the pushbuttons

In order to reset the mapping that has been created:

- Remove the power supply.
- Press the SW1 programming button to supply power to the amplifier and hold this button down until the “beep-beep” confirmation signal is heard (5 seconds).

*Note: This mapping reset function is for all of the outdoor panels with PUSHBUTTONS regardless of the aesthetic design:*

- Cityline outdoor panels
- Marine outdoor panels
- Skyline outdoor panels



2b) Voice-assisted configuration in pushbutton panels

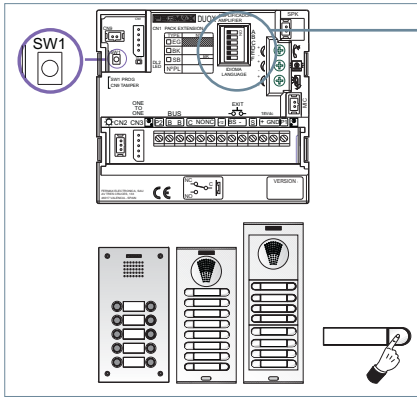

Selection of the language of voice messages by means of the **Synthesiser**. (Languages available: Spanish, English, French, German, Italian and Portuguese).

Note: Voice-assisted configuration is for all of the outdoor panels with **PUSHBUTTONS** regardless of the aesthetic design:

- Cityline outdoor panels
- Marine outdoor panels
- Skyline outdoor panels

1. Access the configuration by pressing SW1 4 times in a row. The amplifier will reproduce the "CONFIGURATION" message and will initiate the process.

In order to exit the configuration process you may press and hold SW1 for 5 seconds, or the process will be exited automatically if no activity is detected for 30 seconds.

See diagram.

2. Pressing SW1 will move through the different parameters and will reproduce the following by voice: **parameter and current configured value**.

Once the message has been reproduced, pressing on any call button will modify the value (a BEEP will be heard each time the button is pressed and the value will rise).

Once the entry has been completed it is possible to listen to the reproduction of the new value by allowing 5 seconds to elapse without pressing anything. When the value of the parameter reaches the maximum possible value, a BOOP sound will be heard and the value will be situated in the minimum possible of this parameter.

3. Pressing on the call button for 5 seconds will create a BOOP sound and the parameter, when this is the selection of a number, will be located at its minimum value and if it is a type of value it will be reset to the default value.

DIAGRAM

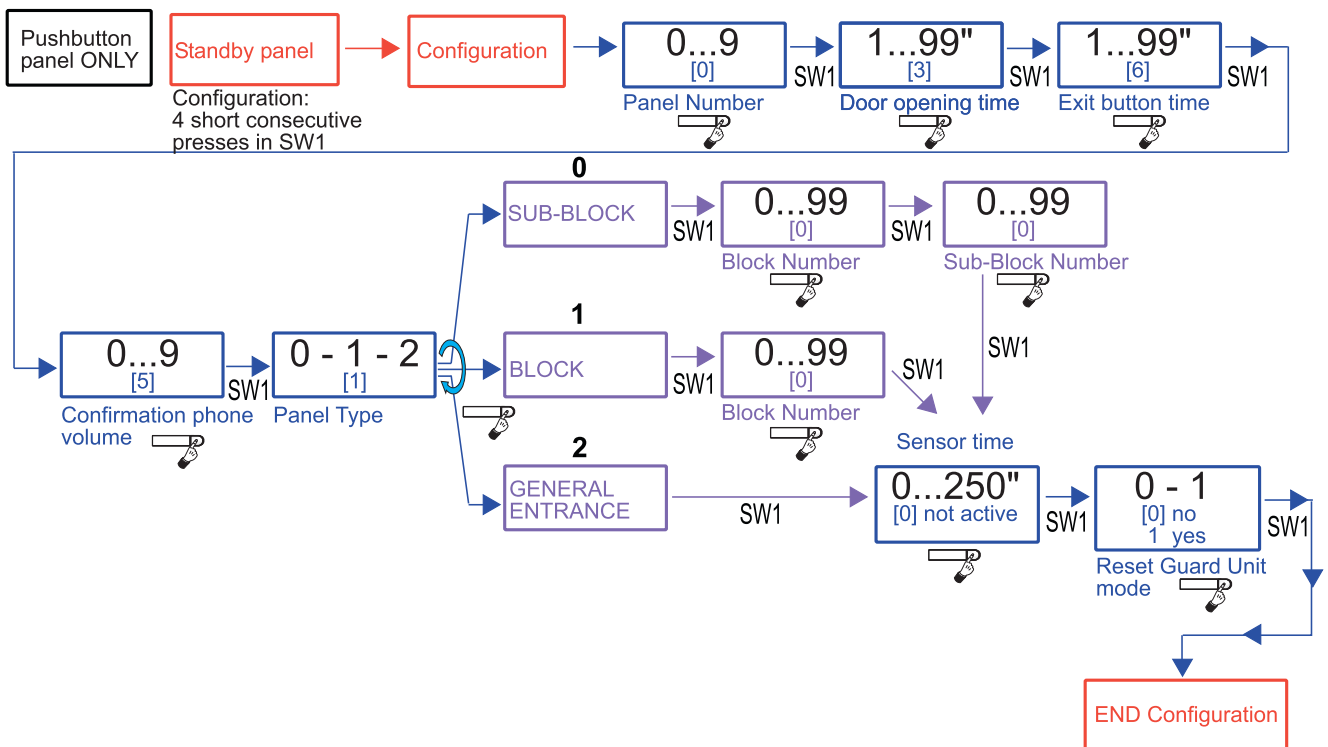

 c) PRE-WIRING

1c) Call extension module

One of the benefits of the DUOX system is the fact that it does not use call wires. This is made possible by the fact that the call is placed through the transmission of a digital code which is generated by the outdoor panel amplifier when a given call button is pressed.

In pushbutton panels (Cityline and Marine), one or more call extension modules are used to generate the specific code for each one of the calls. This module converts the pressing of each button on the outdoor panel into a call code.

The call code that is generated by the pushbutton is determined by the connection from the pushbutton to the call extension module.

There are 2 call extension modules:

- Ref. 2441 16-pushbutton call extension module.
- Ref. 2008 8-pushbutton call extension module.

Cityline kit panels with 1 and 2 pushbuttons

It is only the Cityline kit panels with 1 and 2 pushbuttons that do not require the installation of the call extension module.

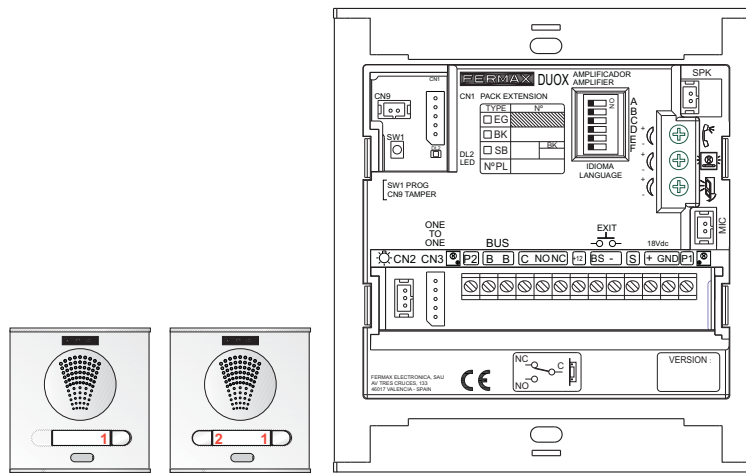

Pre-wiring for Marine kit panels with 1 and 2 pushbuttons with 8-pushbutton call extension module

All of the Marine outdoor panels require the installation of the call extension module, regardless of the number of pushbuttons.

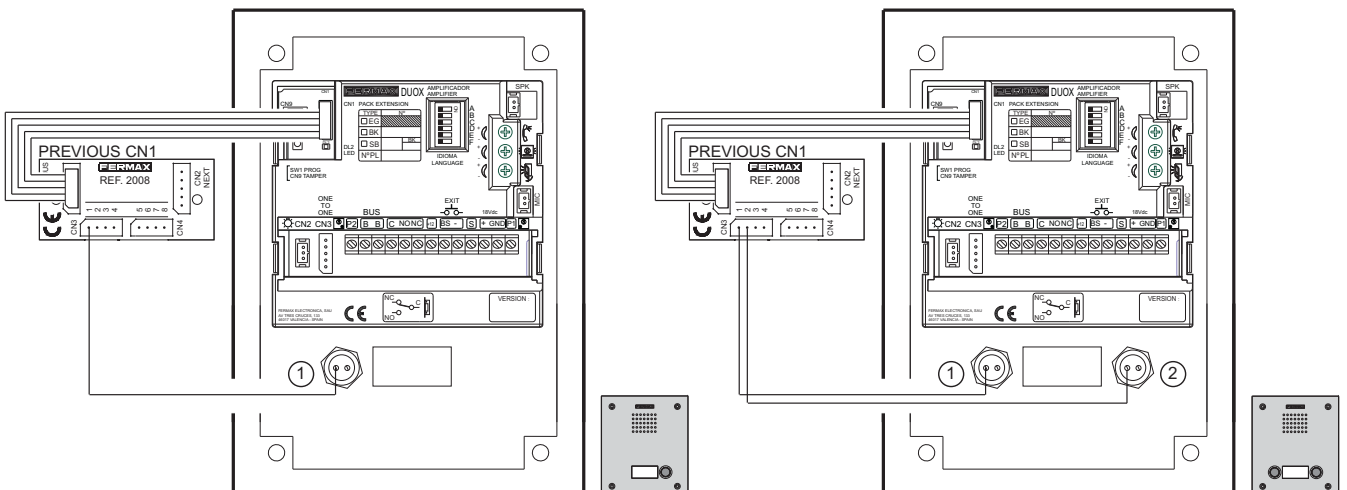

CITYLINE outdoor panel pre-wiring  
 Connection of call extension module Ref. 2441.

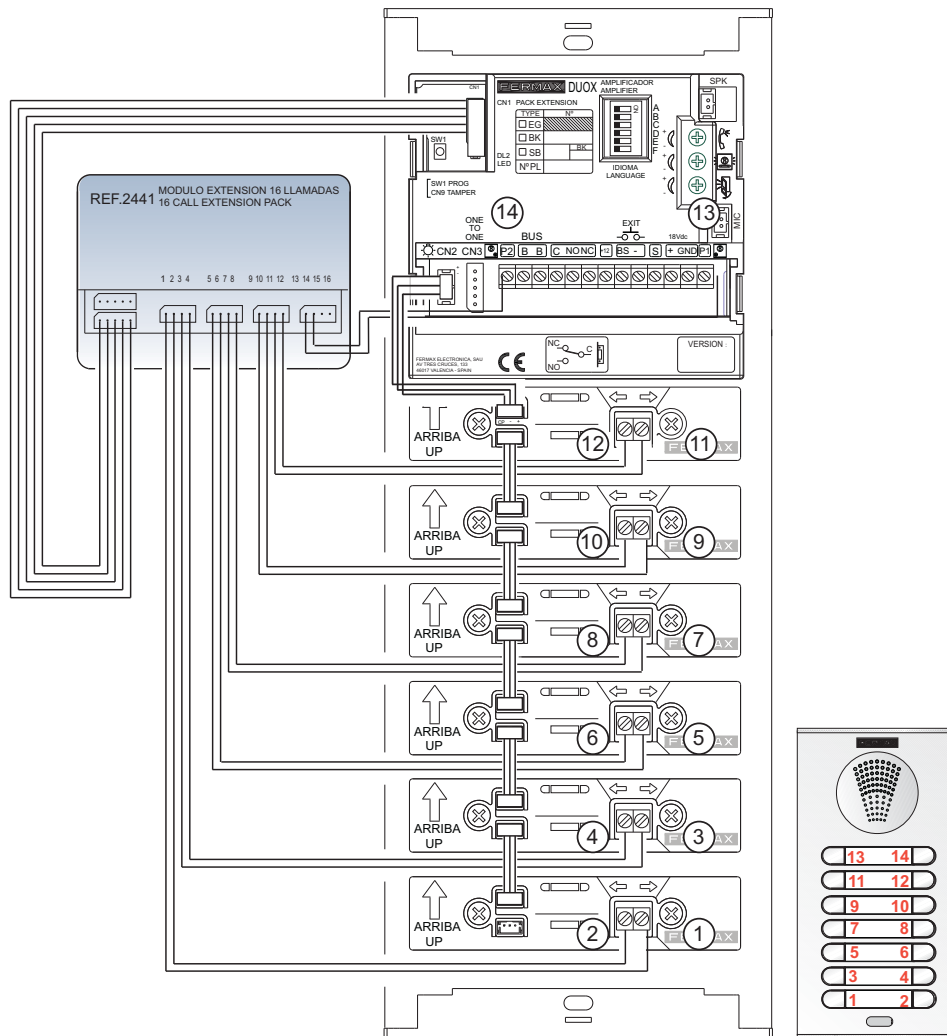

Connection of several call extension modules (more than 16 pushbuttons)

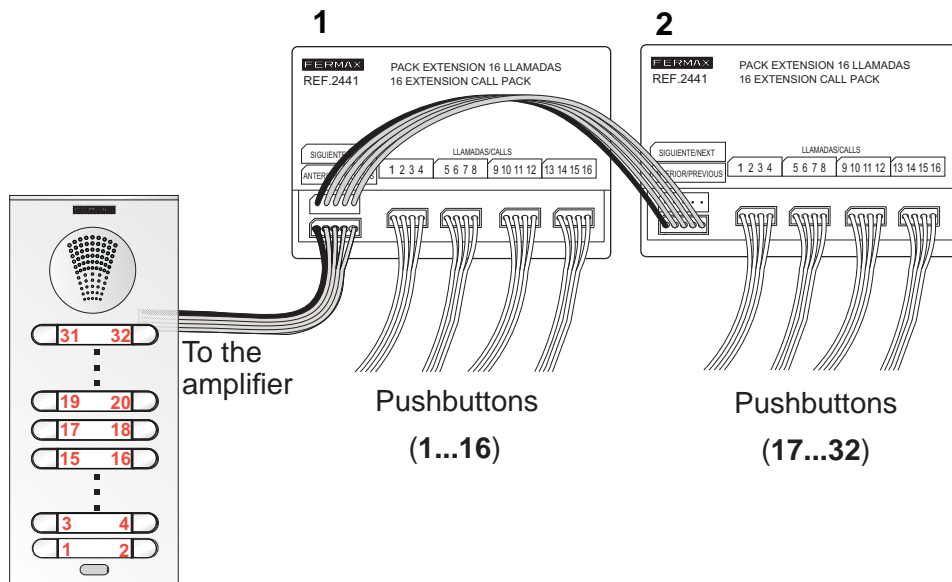

CITYLINE outdoor panel pre-wiring  
 Connection of call extension module Ref. 2008.

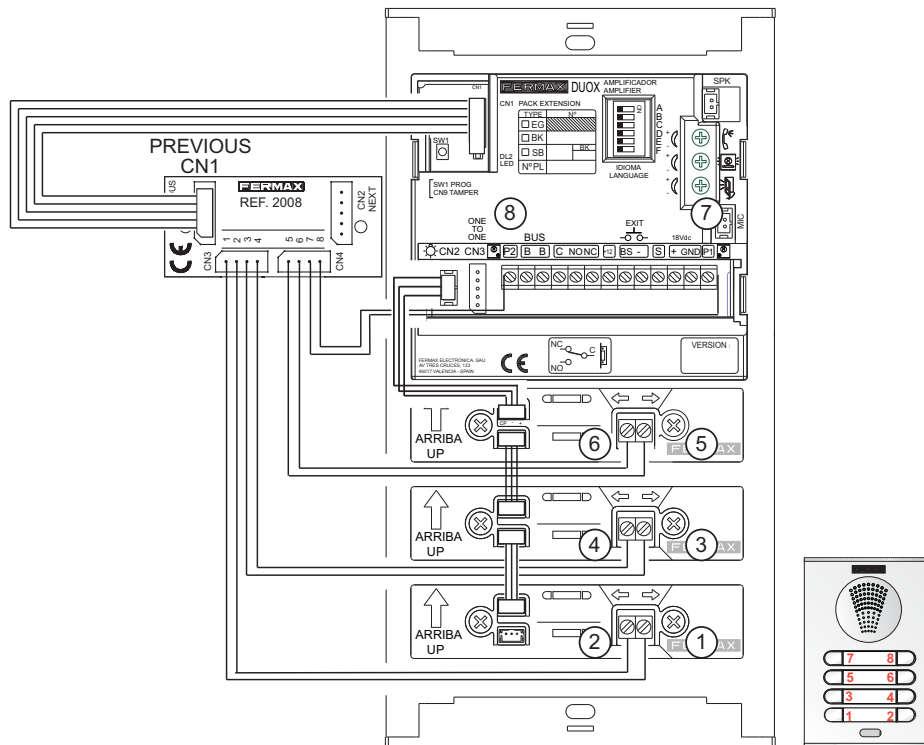

Connection of several call extension modules (more than 8 pushbuttons)

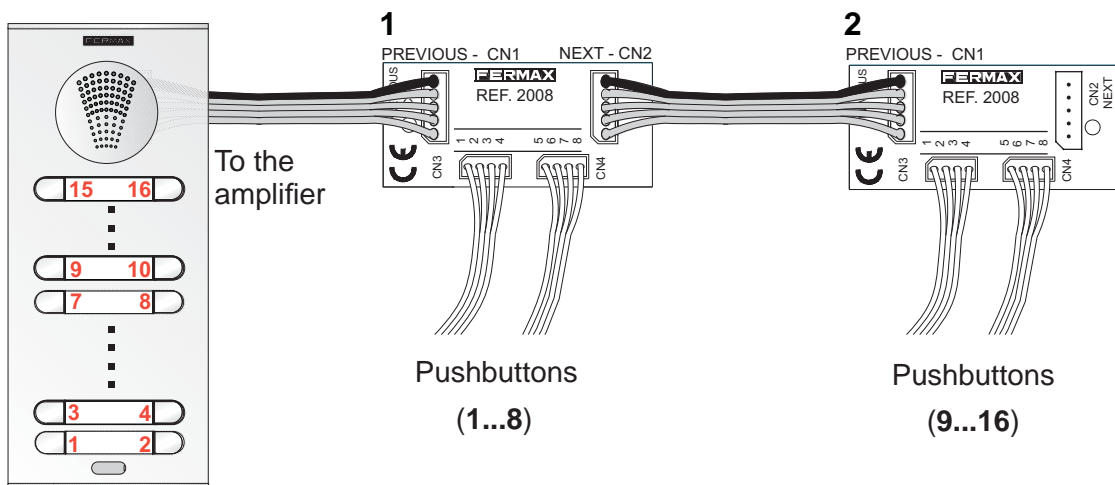

MARINE outdoor panel pre-wiring  
 Connection of call extension module Ref. 2441.

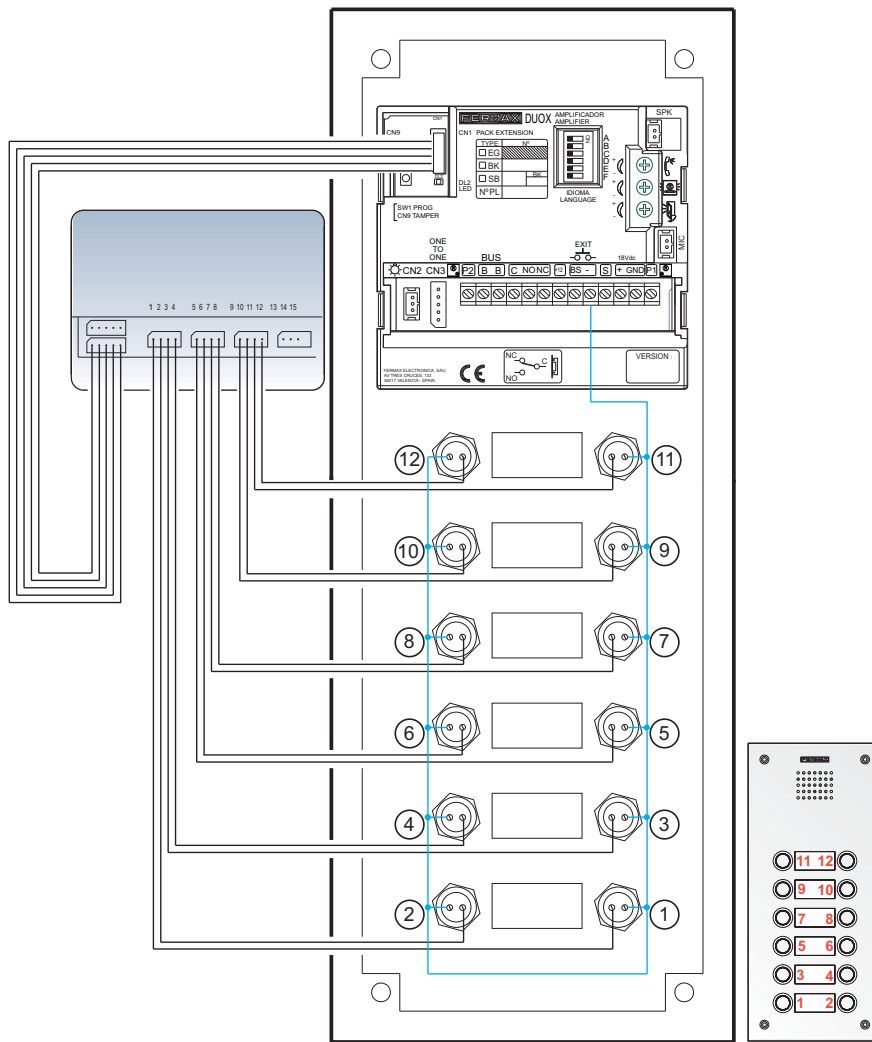

Connection of several call extension modules (more than 16 pushbuttons)

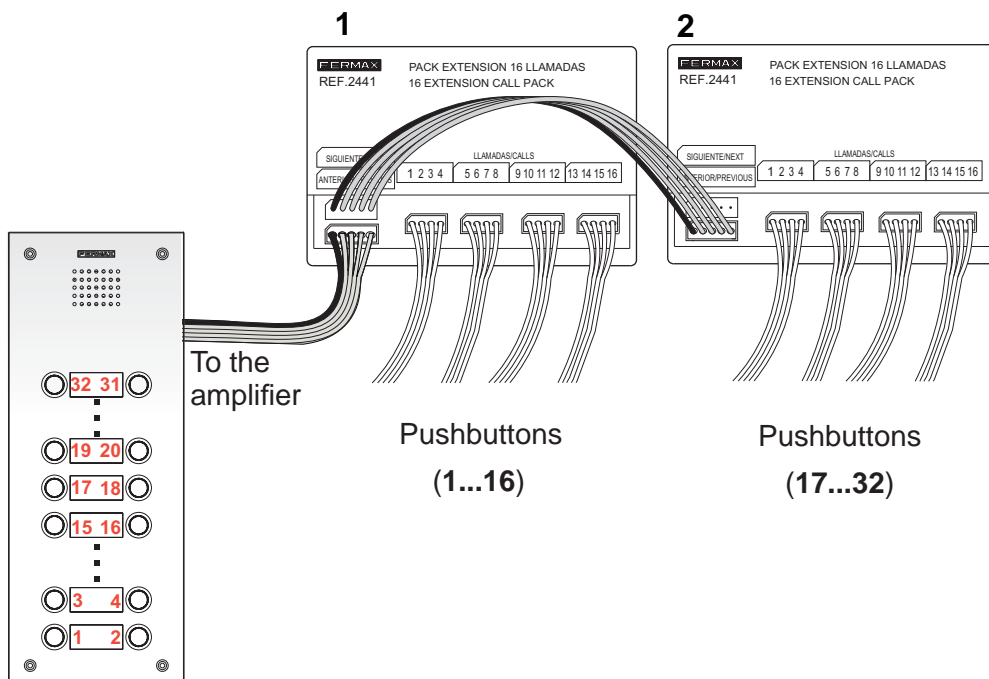

MARINE outdoor panel pre-wiring  
 Connection of call extension module Ref. 2008.

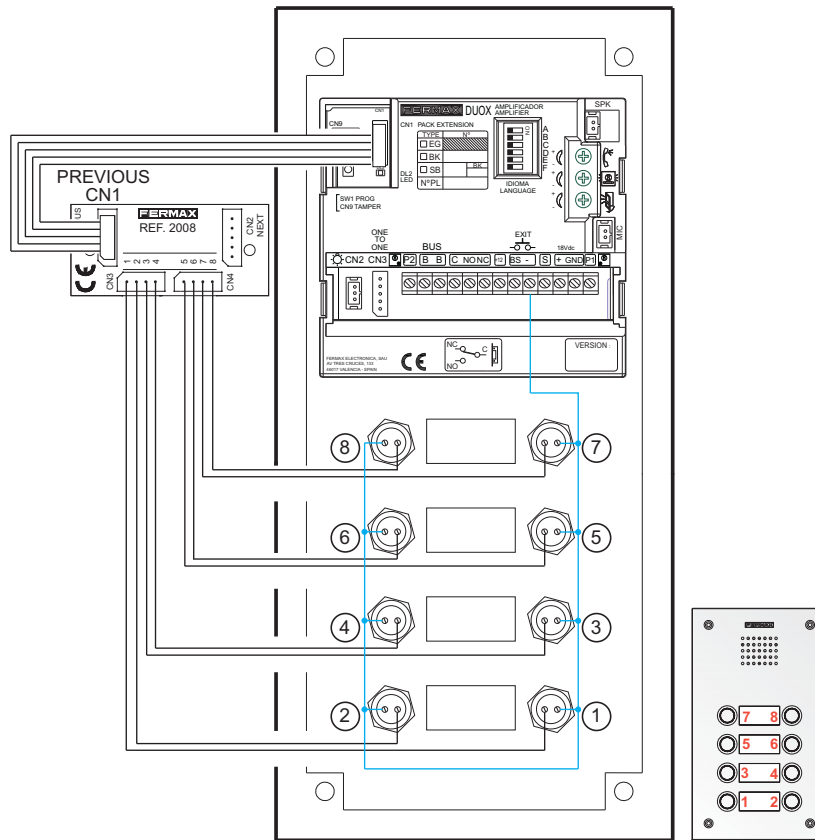

Connection of several call extension modules (more than 8 pushbuttons)

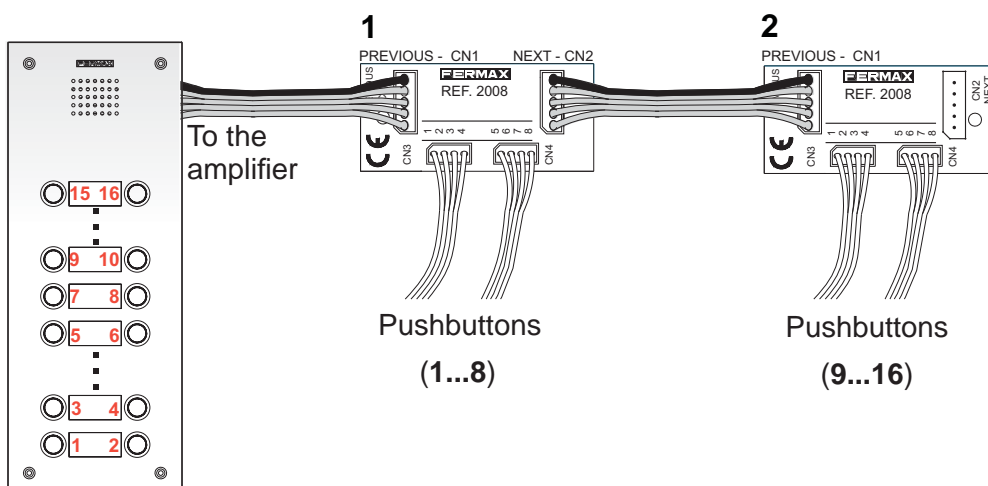

Notes:

- In the event that it is necessary to cover a larger amount of pushbuttons, two or more modules may be used, up to the total of the 90 apartments that enable the DUOX system in pushbutton panels.
- The assignment of call codes by the call extension module may be modified using the "Mapping" function which is available in the DUOX amplifier. See subsection 2.2 Advanced Programming.

2.1.4 AUDIO AMPLIFIER FOR SKYLINE, DIRECT AND DIGITAL OUTDOOR PANELS.

a) SETTINGS

1a) Outdoor panel settings

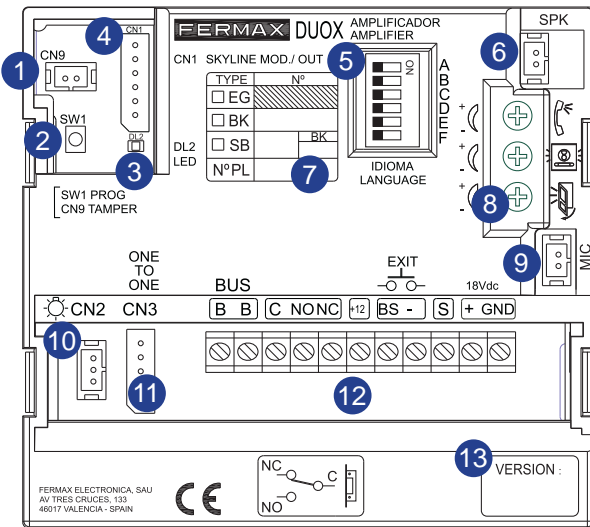

- 1 CN9: TAMPER connection
- 2 SW1 button
- 3 DL2: Status Led  
Intermittent slow blinking. Inverse or Sequential Programming (mapping of pushbutton panels).  
Shut down. Standby.
- 4 CN1 (6 pins)  
Connection of modular pushbuttons, keypad and display.
- 5 Language selection<sup>1</sup>  
of the "door open" message.
- 6 SPK: Loudspeaker connection
- 7 Programming details label
- 8 Audio settings  
of the telephones, the outdoor panel and the open door.
- 9 Microphone connection
- 10 CN2: Individual pushbutton connection (Cityline outdoor panel)
- 11 CN3: OneToOne module connection
- 12 Outdoor Panel Connectors:  
B,B: DUOX Bus: power supply telephones, data and audio.  
C, NO, NC: relay contacts, 2A@30Vdc (lock release connection).  
+12: output 12 Vdc-250mA (maximum 500mA for 100 sec.).  
BS, -: egress pushbutton, (exit button).  
S, -: door sensor input.  
+, GND: not available Later versions.
- 13 Amplifier version

	DIRECT	DIGITAL	PUSH-BUTTONS
CITYLINE			
SKYLINE			
MARINE			

<sup>1</sup>Door open warning language selection

2a) Configuration as master outdoor panel

- Pushbutton panels:

Required in the event that it is necessary to program the apartment terminal.

**Press button SW1** 3 times in quick succession. Once 2 seconds have elapsed, a confirmation tone will sound and the master outdoor panel will be activated. Once the programming of the telephones is complete, it is advisable to deactivate the master outdoor panel by **pressing button SW1** 3 times in quick succession.

*Note: When an outdoor panel is configured as master, this will advise the rest of the outdoor panels which are connected in the installation and if a different outdoor panel has previously been configured as master, it will then cease to be configured as such.*

- Direct outdoor panels: Check [3b\) Configuration table in direct outdoor panels \(subsequent pages\)](#).

- Digital outdoor panels: Check [4b\) Basic configurations of the extra display \(subsequent pages\)](#).

## 3a) Outdoor panel coding\*

Whenever there is more than one outdoor panel, it will be necessary to program the number of outdoor panels.

## 4a ) Lock release activation time\*

Adjusts the door opening time.

\*Note: Consult the relevant sub-section for the type of panel in question:

- Pushbutton panel: 2b) Voice-assisted configuration in pushbutton panels (previous pages).
- Direct outdoor panel: 3b) Configuration table in direct outdoor panels (subsequent pages).
- Digital outdoor panel: 4b) Basic configurations of the extra display (subsequent pages).

## 5a) Technical specifications of the amplifier

Power supply	18 Vdc
Standby consumption	94mA
Active audio consumption 550 mA	
Audio power in the apartment-outdoor panel direction	1 W
Audio power in the outdoor panel-apartment direction	0.15 W
Operating temperature	[-10° , +60°C] / [-14° , 140°F]
Volume adjustable in both directions	

## 6a) Outdoor panel amplifier parameters

Lock release activation time	01...99 sec. (by default: 03)	
Exit button activation time	00...99 sec. (by default: 06) / (deactivated: 00)	
Maximum conversation time	90 sec.	
Type of outdoor panel	sub-block/block/general entrance. (by default: block)	
Block Number	00..99, (by default: 00)	
Sub-Block Number	00..99, (by default: 00)	
Outdoor Panel Number	0..9, (by default: 0)	
Door sensor time	000..250, (by default: 000, non-active)	
Volume monitoring	0..9, (by default: 5)	
Non-active MASTER outdoor panel		
Mapping (pushbutton panel)		
Sequential programming time of pushbuttons following halt of activity	60 sec.	
Inverse programming time of pushbuttons following halt of activity	300 sec.	
Programming code (direct outdoor panel)	0000..9999, (by default: 4444)	
Opening code (direct outdoor panel)	0000..9999, (by default: non-active)	



## b) CONFIGURATION

The DUOX amplifier includes “Restore” and “Change Value” functions which enable users to restore/change the parameters that have been programmed.

### SKYLINE PUSHBUTTON PANEL

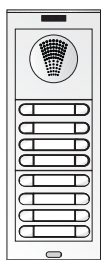

1b) Reset of the mapping of the call code of the pushbuttons

2b) Voice-assisted configuration in pushbutton panels

*Note: See chapter 2.1.3 AUDIO AMPLIFIER FOR CITYLINE AND MARINE PANELS WITH PUSHBUTTONS, sub-section b) CONFIGURATION.*

### DIRECT OUTDOOR PANELS

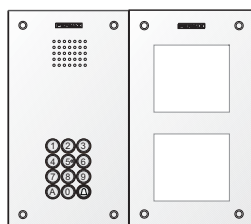
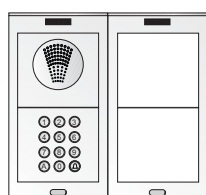

#### 3b) Configuration table in direct outdoor panel

The parameters can be configured using the keypad. In order to do this it is necessary to enter configuration mode using a programming access code after pressing ‘A’.

Entering programming: **A + 4444** (Default programming access code).

If the code is correct, a confirmation tone will sound (beep-beep).

Parameters that may be configured::

Position	Parameter	Setting Values [default]	Commentary
01	Lock release activation time	01-99" [03]	Relay activation of lock release from apartment or access control.
02	Exit button activation time	00-99" [06]	Relay activation of lock release from exit button (terminals <b>Bs</b> and -)
03	Type of outdoor panel	0: Sub-Block [1]: Block 2: General Entrance	Configuration of the type of outdoor panel
04	Block No.	00-99 [00]	Number of the Block which the outdoor panel belongs to
05	Sub-Block No.	00-99 [00]	Number of the Sub-Block which the outdoor panel belongs to
06	Outdoor panel No.	0-9 [0]	Number of the Outdoor Panel
07	Door sensor time	000-250 [000] inactive	Maximum time in which door may remain opened from the opening
08	Opening code	0000-9999 [0000] inactive	Opening code from the keypad. The method of enter the code: A + XXXX (4 digits)
09	Programming	Code 0000-9999 [4444]	Programming access code
10	MASTER Outdoor Panel	[0]: No / 1: If	Activ. of the outdoor panel as the master for the program. of apart. terminals
11	Guard Unit Mode	[0]: No Reset 1: Reset	Reset to night mode by entering “1” in this position
12	Volume Monitoring	0-9 [5]	Set the volume of the outdoor panel monitoring
13	RESET parameters	[0]: No Reset 1: Reset	Recuperate the default values by entering “1” in this position

**Configuration of parameters**

Enter the two digits from the position, a “beep” will sound, then enter the chosen value (1, 2, 3 or 4 digits depending on the parameter). If the value is correct, a confirmation tone will sound (beep-beep) and the new value will be saved. If the value is incorrect, the error tone will sound (bop).

**Position + Possible values**

01...14 (beep) 1, 2, 3 or 4 digits (beep-beep)

**Commentary**

Digits based on the parameter chosen

**Examples**

09 (beep) 1128 (beep-beep)

Change of programming code to 1128

01 (beep) 02 (beep-beep)

Change of lock release activation time to 2 seconds

In order to exit the programming, press ‘A’ while entering the menu position number. Programming will also be exited after 60” if no key is pressed, generating a beep-beep tone.

**DIGITAL OUTDOOR PANELS**



**4b) Basic configurations of the extra display**

Different parameters can be configured using the display.. In order to do this it is necessary to enter programming mode.

**ENTER PROGRAMMING MODE**

Press A and enter the access code:  
AB21AB

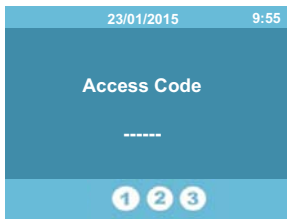

Enter the programming code:  
19025 (by default)



If an incorrect code is entered there will be a revert to standby

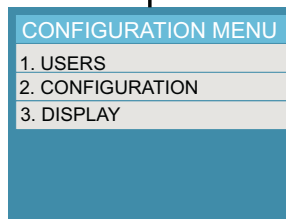

**CONFIGURATION MENU.**

Main options menu. Use the dialling keypad to choose the option desired. Parameters that may be configured::

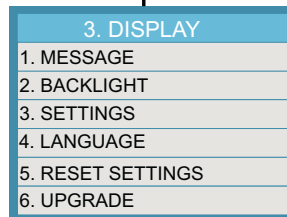
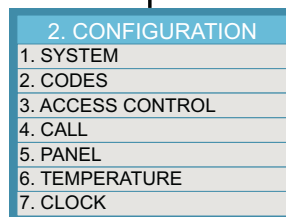
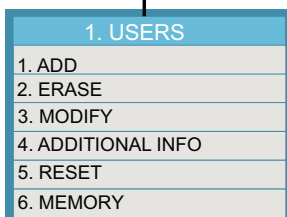

Depending on the **programming code** that has been entered (installer, administrator or concierge code), some of these functions may not appear.

*Note: For more information about the display functions see instructions code. 97869 Quick guide to extra display programming, available on the website.*

**2. CONFIGURATION:** This enables the setting of the parameters of the outdoor panel. Use the numeric keypad to select the desired configuration option.

2. CONFIGURATION	
1. SYSTEM	
2. CODES	
3. ACCESS CONTROL	
4. CALL	
5. PANEL	
6. TEMPERATURE	
7. CLOCK	

3. ACCESS CONTROL	
1. DOOR OPEN TIME	
2. HALL TIME	
3. PROX READER	
4. PIN REQUEST	
5. DOOR SENSOR	

**3. ACCESS CONTROL.**  
This option enables the configuration of the parameters relating to the door openings and the access control. Within each option, use the keypad to enter the data and use B to confirm.

1. DOOR OPENING TIME	
03	
Delete	A
Exit	B

Lock release activation time. Activation of the lock release relay from the apartment or the access control.  
*Value settings [default] 01-99" [03].*

2. HALL TIME	
06	
Delete	A
Exit	B

Hall time. Activation of the lock release relay from the exit button (terminalsBs and -).  
*Value settings [default] 00-99" [06].*

5. DOOR SENSOR	
--	
Delete	A
Exit	B

Door sensor time. Maximum time that the door may be open from the door opening.  
*Value settings [default] 000-250" [000] inactive.*

5. PANEL	
1. PANEL NAME	
2. PANEL NUMBER	
3. PANEL TYPE	
4. MASTER	
5. BLOCK	

**5. OUTDOOR PANEL.**  
This option enables the configuration of the parameters relating to the panel. Within each of the options, use the arrows as selection tools or use the keypad to enter the data and use B to confirm.

1. PANEL NAME	
EDIFICIO SOL----	
Delete	A
Exit	B

2. PANEL NUMBER	
00	
Delete	A
Exit	B

Outdoor panel number.  
*Value settings [default] 0-9 [0]*

3. PANEL TYPE	
◀ Block Entrance ▶	
Exit	B

Configuration of the type of outdoor panel.  
- General Entrance:  
- Block Entrance (by default).  
- Sub-Block Entrance .

4. MASTER	
◀ Disabled ▶	
Exit	B

Activation of the outdoor panel as the master for the programming of apartment terminals. Once the programming of the monitors/telephones is complete, it is advisable to deactivate the master outdoor panel.

5. BLOCK	
00	
Delete	A
Exit	B

Number of the:  
- Block: 00-99 [00]  
or  
- Sub-Block: 00-99 [00]  
(depending on the type of outdoor panel chosen in option3. **TYPE OF OUTDOOR PANEL**, to which the outdoor panel belongs).

**c) PRE-WIRING**

**1c) Skyline Outdoor Panels**

The DUOX Skyline outdoor panels form the line of continuous profile outdoor panels with modular composition. Assembling the outdoor panel is very simple. Simply select the combination of modules, fit these in position and connect them using the connection cables.

*Note: It is possible to use pushbuttons combined with a keyboard in order to be able to make direct calls to certain apartments (liberal professions).*

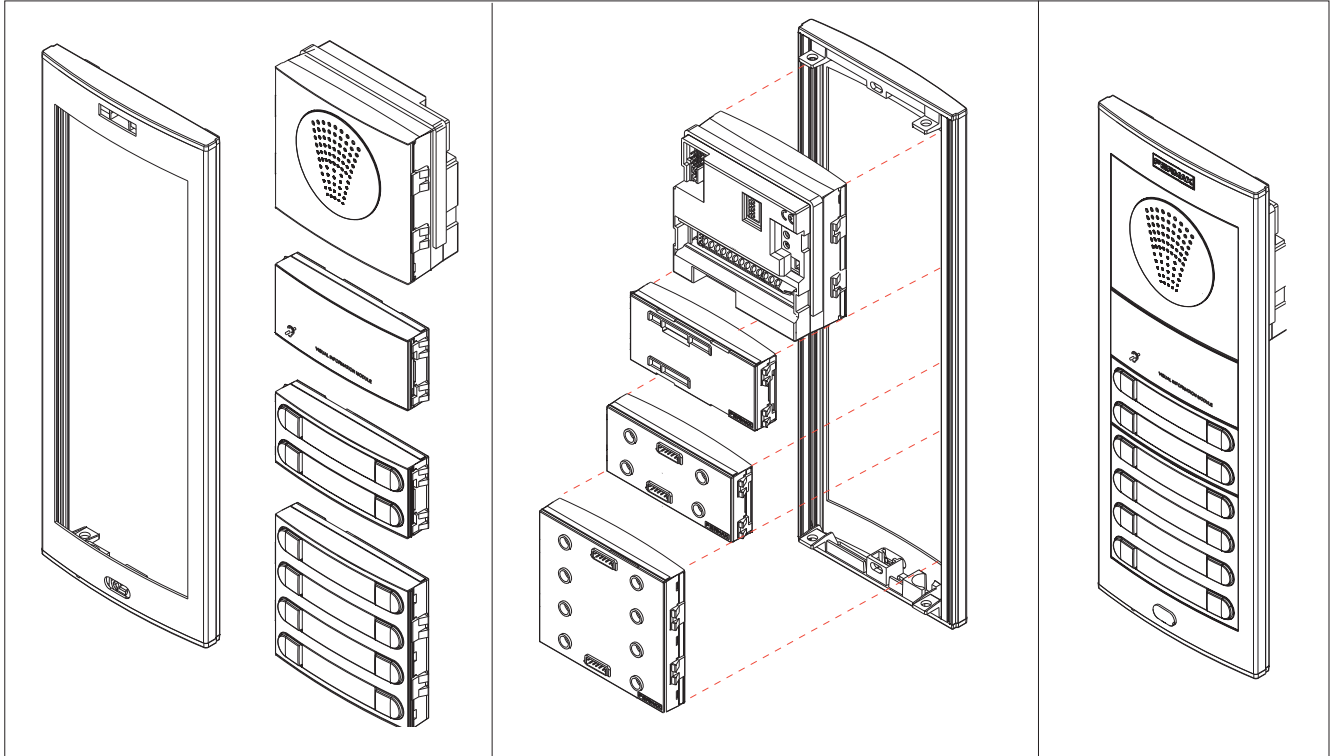

**Microphone connection**

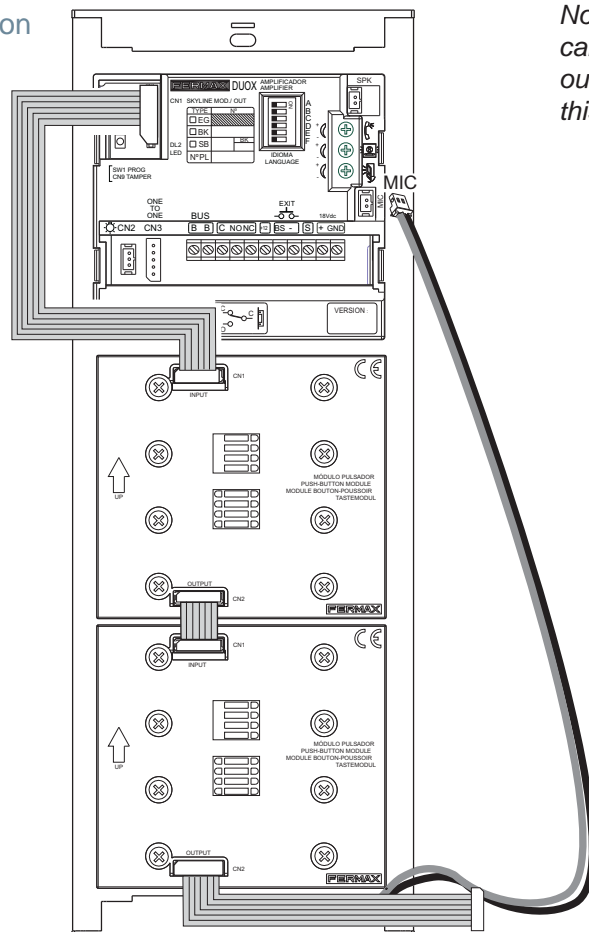

*Note: Do not position the microphone cable inserted along the profile of the outdoor panel. We recommend locating this in the module clippings. See detail.*

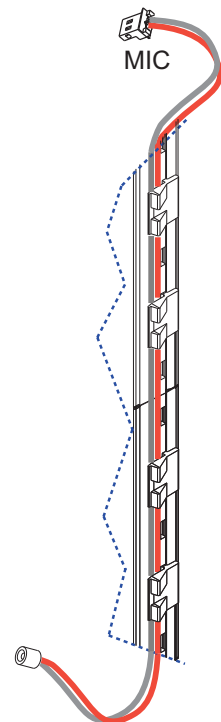

Pre-wiring for PUSHBUTTONS Skyline outdoor panel

The Skyline pushbutton modules do not require call extension modules because these modules include the call code generation feature.

The DUOX amplifier automatically assigns the call codes to the pushbuttons of the connected modules.

The call codes assigned to the pushbuttons can be modified using the mapping function. [See subsection 2.2 Advanced Programming.](#)

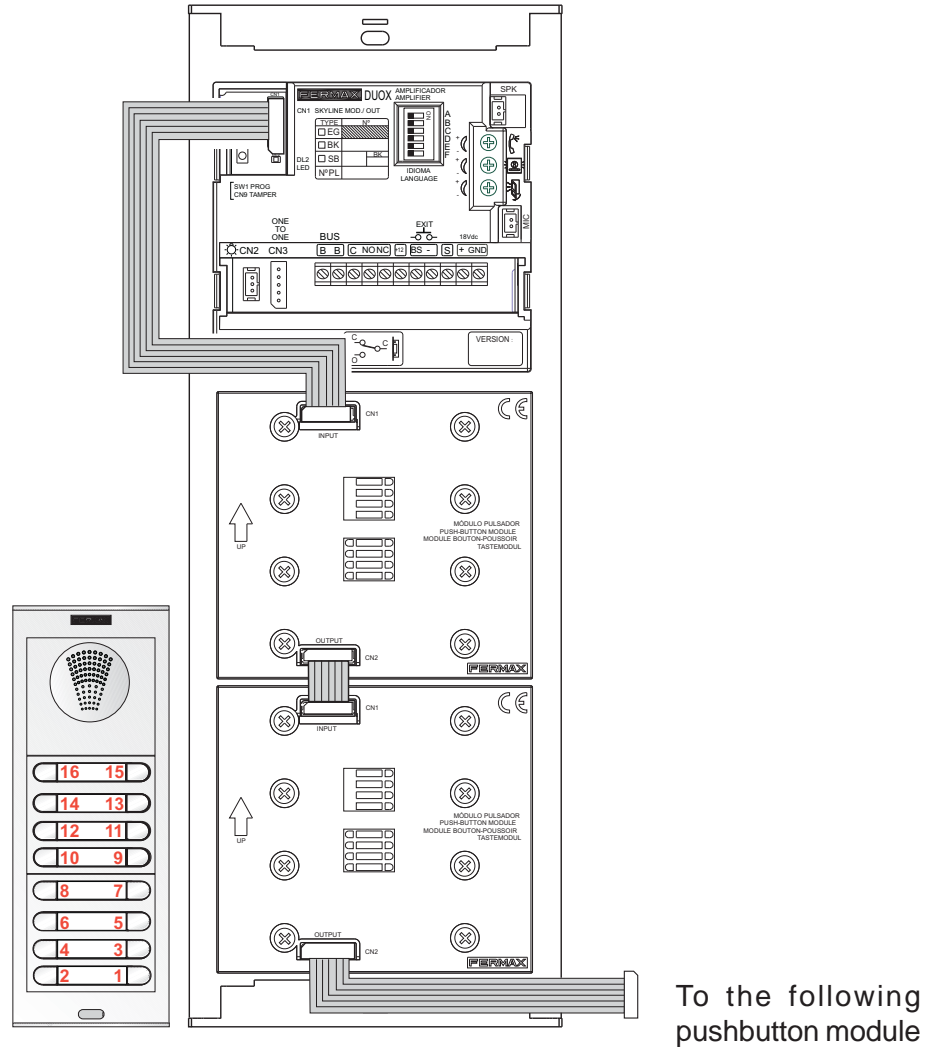

DUOX addresses assigned by the amplifier

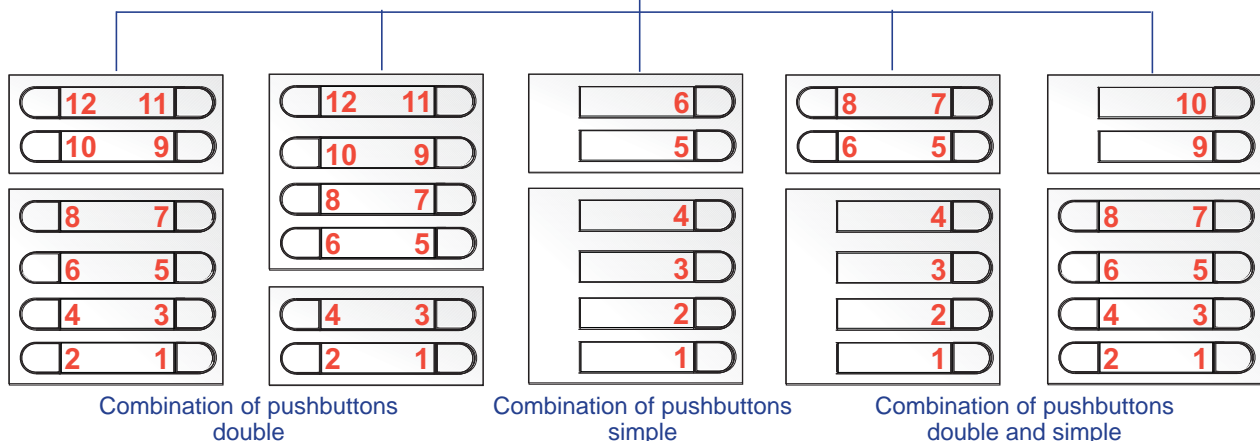

Pre-wiring for DIRECT Skyline outdoor panel

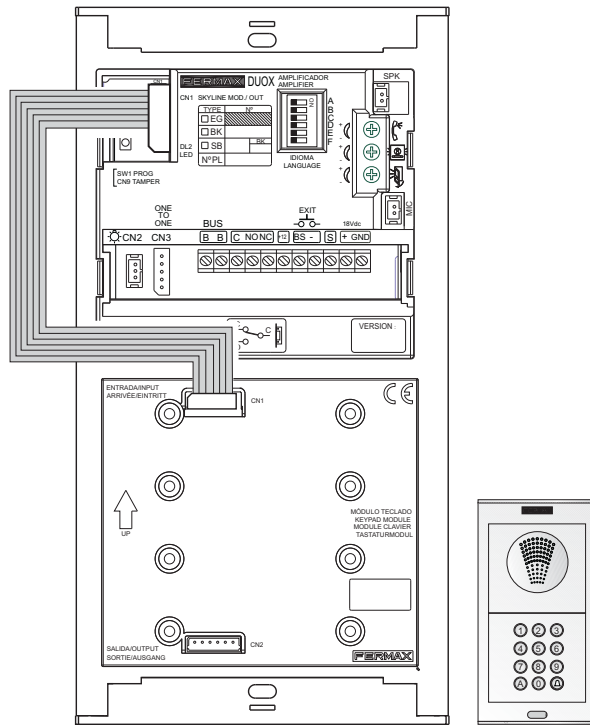

Pre-wiring for DIGITAL Skyline outdoor panel

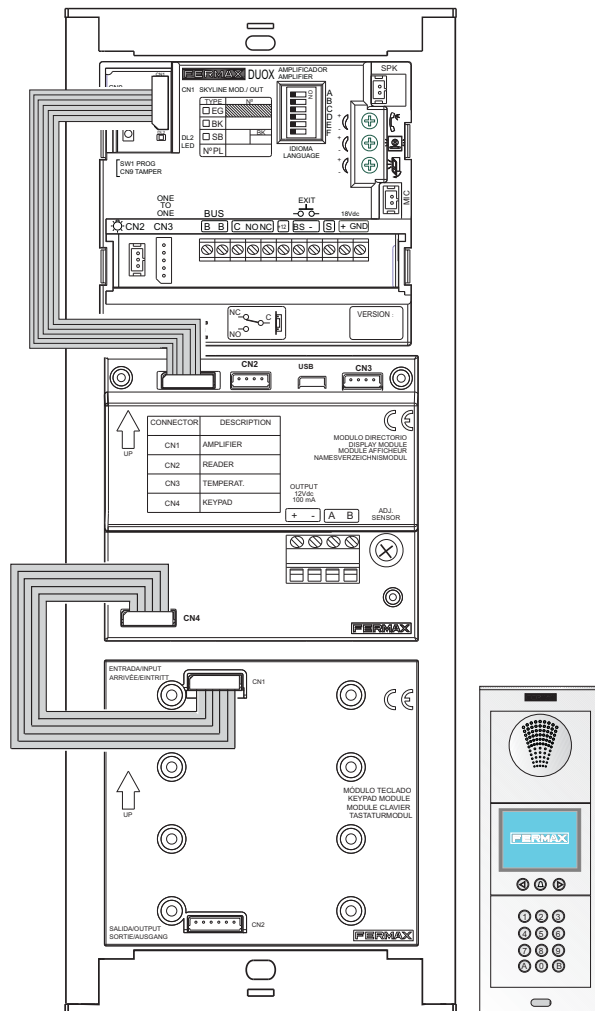

### 2c) Cityline Outdoor Panels

#### Pre-wiring for DIRECT Cityline outdoor panel

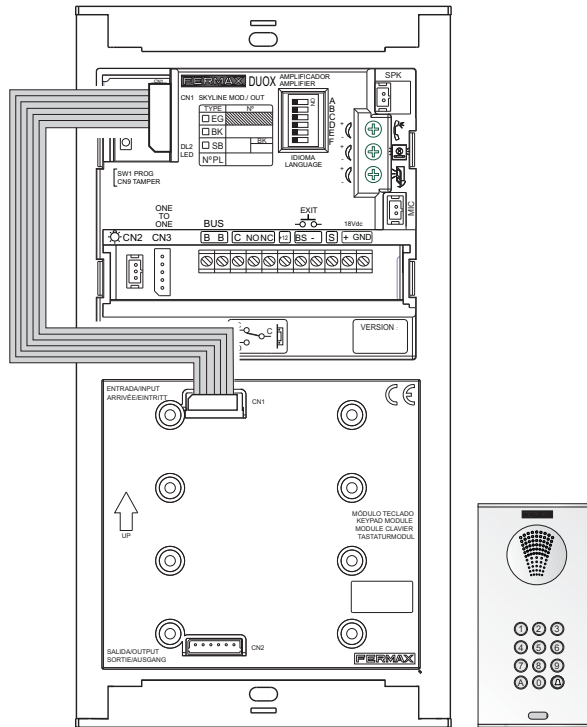

#### Pre-wiring for DIGITAL City outdoor panel

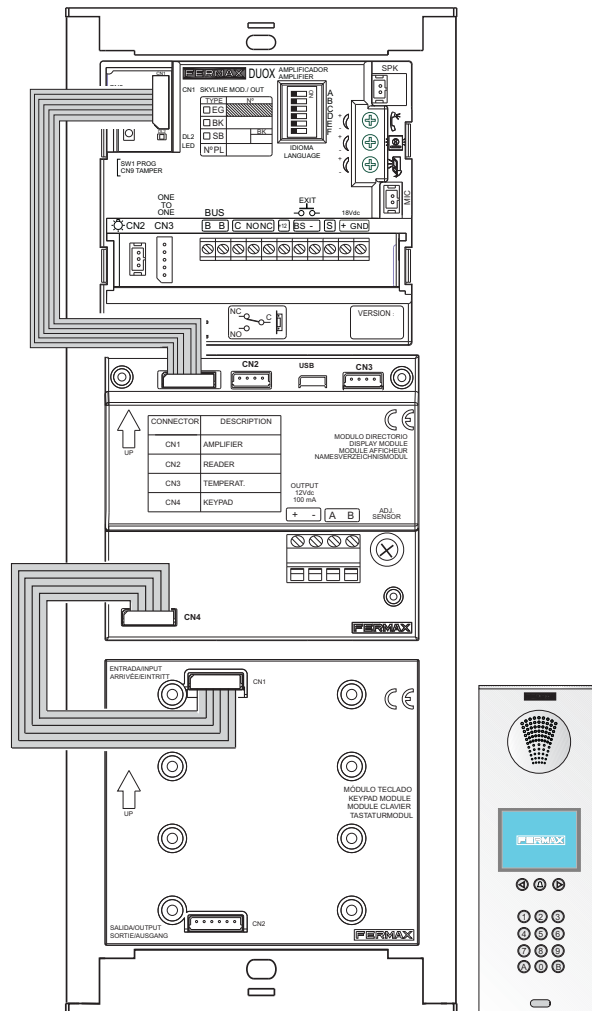

### 3c) Marine Outdoor Panels

#### Pre-wiring for DIRECT Marine outdoor panel

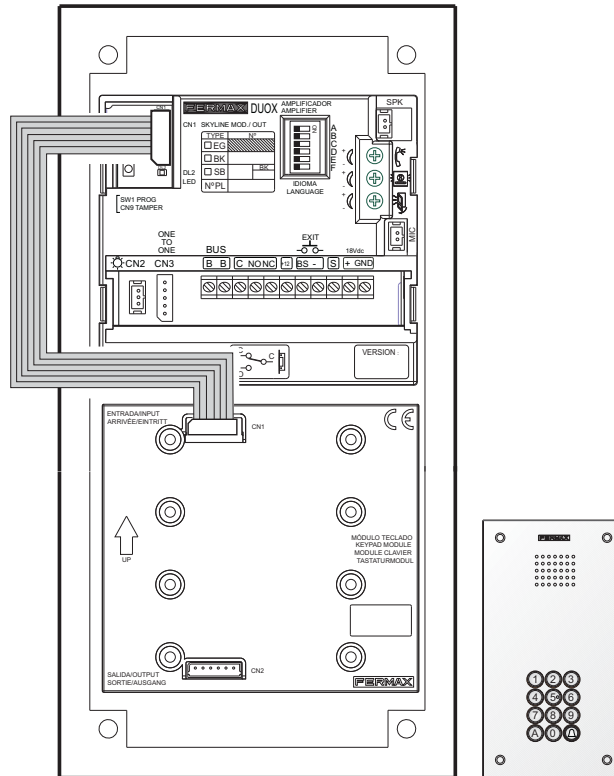

#### Pre-wiring for DIGITAL Marine outdoor panel

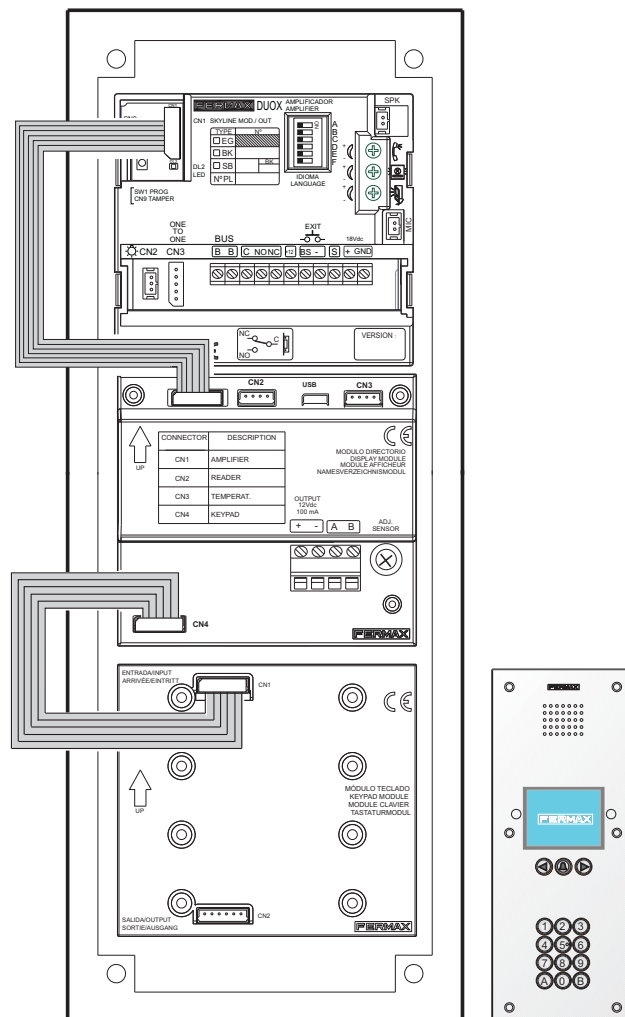



## 2.2 ADVANCED PROGRAMMING

### 2.2.1 MAPPING IN PUSHBUTTON PANELS

The call code generated by a pushbutton of a pushbutton panel is determined by:

- Integrated pushbuttons in the “amplifier” of Cityline 1- or 2-line outdoor panels.
- The connection to the “call extension module”:
  - in Cityline outdoor panels with more than 2 pushbuttons and
  - in all of the Marine outdoor panels with pushbuttons
- The interconnection of the “pushbutton module” in Skyline modular outdoor panels.

**Mapping** is an advanced programming function which is available in the pushbutton panels. Mapping enables users to modify the call code that is assigned to pushbuttons:

- “naturally”, by the position in a call extension module
- or
- sequentially, per pushbutton module (from bottom to top and from right to left).

Mapping makes it possible to cover all eventualities in the coding of pushbuttons:

#### Standard assignment

Depends on the wiring of the call extension module.

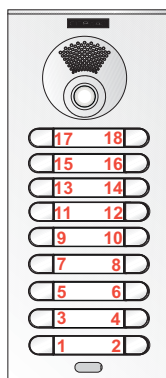

Pushbutton module: sequential, from bottom to top and from right to left.

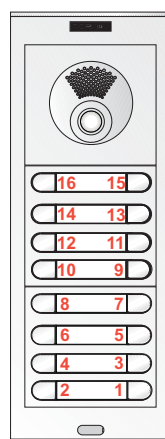

#### Mapping

Examples of possible assignments using the mapping function:

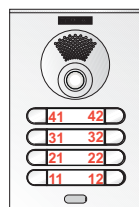

Floor/Apartment  
Very useful in installations with a general entrance

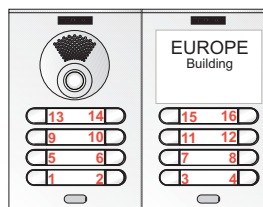

Includes double panel: call assignment per floor based on the distribution of apartments.

There are 2 mapping methods:

#### 1. Inverse Programming.

In the event that it is necessary for the pushbuttons to generate non-consecutive call codes as is the case for codes which include a floor number and an apartment number.

#### 2. Sequential Programming.

In the event that a special distribution is required. On the outdoor panel(s), press the call buttons in the order in which the codes are to be assigned, beginning with 0 (video amplifier)/ beginning with 1 (audio amplifier) and continuing in consecutive order until reaching the final one. *Check the examples in the Notes in subsequent pages.*

Notes:

- Programming is always performed using the activated outdoor panel as the master. Press button SW1 3 times in quick succession. Once 2 seconds have elapsed, a confirmation tone will sound and the panel will be activated as the master. Once the programming is complete, it is advisable to deactivate the master outdoor panel by pressing button SW1 3 times in quick succession.
- To enter in any of the pushbutton mapping modes the amplifier must be in standby mode.

## VIDEO Amplifier

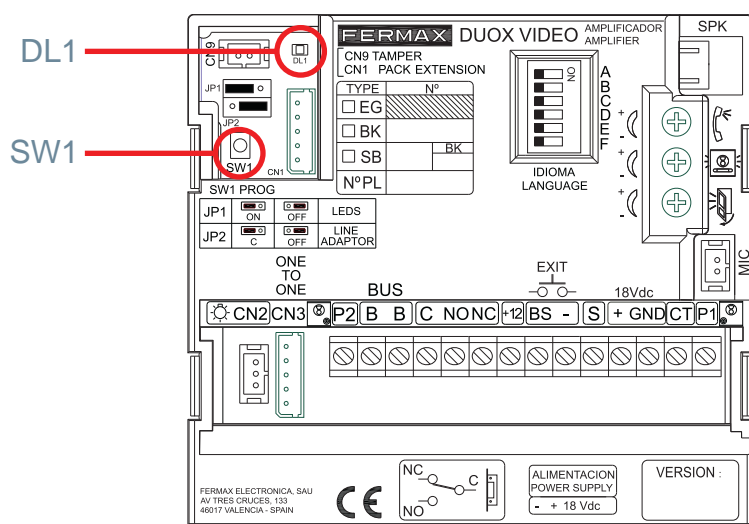

## INVERSE PROGRAMMING.

2 operators are required.

This mode enables the assignment of non-consecutive call codes (addresses).

The steps to be taken are as follows:

1. The outdoor panel should first be configured as the master outdoor panel (*see note on previous page*).
2. Programme the monitor locally and independently using an outdoor panel, a guard unit or from the monitor itself. *See subsection 7. Apartment Terminals.*
3. Enter the “inverse pushbutton programming” mode of the amplifier.

Hold down button SW1 for 10 seconds until you hear a “beep” noise. Release button SW1. The Mode LED (DL1) is activated to indicate entry into inverse programming mode (intermittent slow: 1 blink/second slow).

4. Assign the new addresses to each pushbutton:

4.1 Enter the programming mode of the apartment terminal. An enter programming mode tone will sound. Picking up, a conversation will begin with the master outdoor panel to indicate the pushbutton of the apartment to be programmed.

4.2. Hang up the monitor, press the outdoor panel, the call button associated with this apartment.

This pushbutton will be assigned the call code that has previously been programmed in the monitor (store in the amplifier).

Repeat step 4 with all of the apartment terminals-pushbuttons in the installation.

*Note: If a pushbutton is pressed in inverse programming without monitor programming having been entered, the amplifier will emit a “bop” error tone.*

5. Exit programming:

Press the pushbutton of amplifier SW1 again.

The amplifier will automatically exit programming after 5 minutes of inactivity.

Notes:

- Depending on the range of call codes it will be necessary to configure the outdoor panel (amplifier) accordingly. If all of the monitors:

- Have the same block and sub-block address (BBSSNN) the outdoor panel will be configured as a sub-block (or block) outdoor panel with these values.
- Only have the block address in common, the outdoor panel will be configured as a block outdoor panel.
- Have different block numbers the outdoor panel will be configured as a general entrance.

- Configuration - Amplifier Programming: The DUOX amplifier may be configured to enable operation as a general entrance outdoor panel, a block entrance outdoor panel or a sub-block entrance outdoor panel. *See chapter 1. INTRODUCTION - 1.5 Call coding.*

## SEQUENTIAL PROGRAMMING.

Only 1 operator is required.

This mode enables the sequential assignment of call codes (directions) in the order desired.

The steps to be taken are as follows:

1. The outdoor panel should first be configured as the master outdoor panel (*see note on previous page*).

2. Enter the “sequential pushbutton programming” mode of the amplifier.

Hold down the SW1 button for 10 seconds until a “beep” sounds and keep it held down for a further 5 seconds (a double “beep” will sound). On releasing the button, the Mode LED (DL1) will be activated to indicate that we have entered sequential programming mode (intermittent slow: 1 blink/second fast).

3. Assign the new addresses to each pushbutton:

On the outdoor panel, press the call button in the order in which you wish to associate the codes, starting with 0 and working sequentially until reaching the last one.

- 1st Push = Code 0 (BBSS00). *See Notes.*

- 2nd Push = Code 1 (BBSS01).

- 3rd Push = Code 2 (BBSS02).

- and so on and so forth.

The amplifier will store the new call codes of each pushbutton.

4. Exit programming:

Press the SW1 amplifier “pushbutton programming” pushbutton again.

The amplifier will automatically exit programming after 5 minutes of inactivity.

*Notes:*

- *If you wish to programme the buttons without starting from the number 0 or to suddenly alter the number from which you wish to continue programming, press the pushbutton to be configured repeatedly until reaching the value of the calculation that you wish to assign.*

• **For example:** *if you wish to assign the values 1, 5 and 10 to three pushbuttons on an outdoor panel, press the first button twice, the second button 4 times and the third button 5 times.*

- *You may configure a pushbutton with Code 0 to make a call to the Guard Unit (if applicable).*

- *Depending on the range of call codes it will be necessary to configure the outdoor panel (amplifier) accordingly.*

## RESET mapping in pushbutton panels

In order to reset the mapping that has been made:

- Remove the power supply.

- Press the SW1 programming button to supply power to the amplifier and hold this button down for 5 seconds. You should hear a “beep” sound. The LED (DL1) will blink rapidly to indicate that the restore process has taken place.

## AUDIO Amplifier

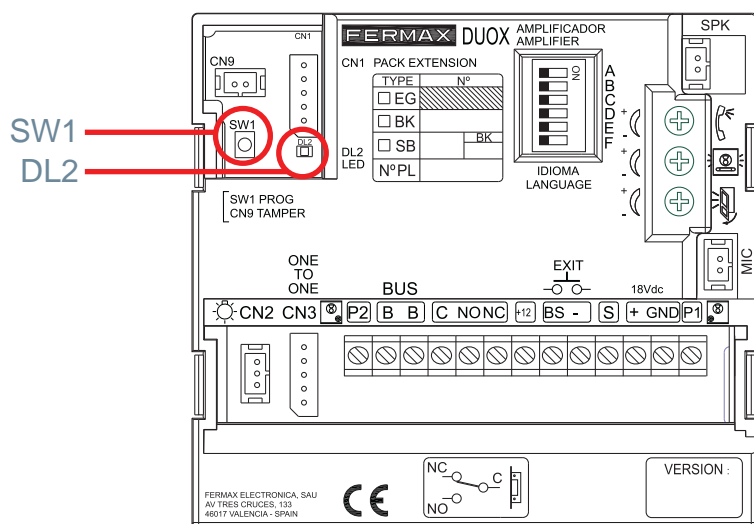

## INVERSE PROGRAMMING.

2 operators are required.

This mode enables the assignment of non-consecutive call codes (addresses).

The steps to be taken are as follows:

1. The outdoor panel should first be configured as the master outdoor panel (*see note on previous page*).
2. Programme the telephone locally and independently using an outdoor panel or guard unit. *See subsection 7. Apartment Terminals.*
3. Enter the “inverse pushbutton programming” mode of the amplifier.

Hold down the SW1 button for 10 seconds until you hear a “beep” noise. Release button SW1. The Mode Led (DL2) is activated to indicate that we have entered inverse programming mode (intermittent slow: 1 blink/second slow).

4. Assign the new addresses to each pushbutton:

4.1 Enter the programming mode of the apartment terminal. An enter programming mode tone will sound. Picking up, a conversation will begin with the master outdoor panel to indicate the pushbutton of the apartment to be programmed.

4.2 Hang up the telephone and press the outdoor panel, the call button associated with this apartment. This pushbutton will be assigned the call code that has previously been programmed in the monitor (stored in the amplifier).

Repeat step 4 with all of the apartment terminals-pushbuttons in the installation.

5. Exit programming:

Press the pushbutton of amplifier SW1 again.

The amplifier will automatically exit programming after 5 minutes of inactivity.

## Notes:

- Depending on the range of call codes it will be necessary to configure the outdoor panel (amplifier) accordingly. If all of the telephones:
  - Have the same block and sub-block address (BBSSNN) the outdoor panel will be configured as a sub-block (or block) outdoor panel with these values.
  - Only have the block address in common, the outdoor panel will be configured as a block outdoor panel.
  - Have different clock numbers the outdoor panel will be configured as a general entrance.
- Configuration - Amplifier Programming: The DUOX amplifier may be configured to enable operation as a general entrance outdoor panel, a block entrance outdoor panel or a sub-block entrance outdoor panel. *See chapter 1. INTRODUCTION - 1.5 Call coding.*

## SEQUENTIAL PROGRAMMING.

Only 1 operator is required.

This mode enables the sequential assignment of call codes (directions) in the order desired.

The steps to be taken are as follows:

1. The outdoor panel should first be configured as the master outdoor panel (*see note on previous page*).

2. Enter the “sequential pushbutton programming” mode of the amplifier.

Hold down the SW1 button for 10 seconds until a “beep” sounds and keep it held down for a further 5 seconds (a double “beep” will sound). On releasing the button, the Mode LED (DL2) will be activated to indicate that we have entered sequential programming mode (intermittent slow: 1 blink/second fast).

3. Assign the new addresses to each pushbutton:

On the outdoor panel, press the call button in the order in which you wish to associate the codes, starting with 1 and working sequentially until reaching the last one.

- 1st Push = Code 1 (BBSS01).
- 2nd Push = Code 2 (BBSS02).
- 3rd Push = Code 3 (BBSS03).
- and so on and so forth.

The amplifier will store the new call codes of each pushbutton.

4. Exit programming:

Press the SW1 amplifier “pushbutton programming” pushbutton again.

The amplifier will automatically exit programming after 5 minutes of inactivity.

Notes:

- *If you wish to programme the buttons without starting from the number 1 or to suddenly alter the number from which you wish to continue programming, press the pushbutton to be configured repeatedly until reaching the value of the calculation that you wish to assign.*
- **For example:** *if you wish to assign the values 1, 5 and 10 to three pushbuttons on one outdoor panel, press the first button once, the second button 4 times and the third button 5 times.*
- *Depending on the range of call codes it will be necessary to configure the outdoor panel (amplifier) accordingly.*

## RESET mapping in pushbutton panels

In order to reset the mapping that has been made:

- Remove the power supply.
- Press the SW1 programming button to supply power to the amplifier and hold this button down until the “beep-beep” confirmation signal is heard (5 seconds).

## 2.2.2 MAPPING IN DIGITAL OUTDOOR PANELS

62

**Mapping** is an advanced programming option which is also available in digital outdoor panels. Mapping enables the modification of the call code that has been inherently assigned by the system for another different call code in order to cover all of the coding requirements.

In these outdoor panels call coding can be effectuated using any character (letters and numbers) up to a maximum of 6.

Mapping can be effectuated from the outdoor panel (keypad + display) or using the extra display software. The Display Plus software is a PC-based application which serves to exchange data with the FERMAX EXTRA DISPLAY unit.

This exchange of data makes it possible to perform different operations with the display, meaning that the Display Plus software can be considered as a tool which enables the installer to perform certain tasks that would be more cumbersome if they were to be performed through the keypad of the outdoor panel in which the display is installed.

Notes:

- For more information about the display functions see [instructions code. 97869 Quick guide to extra display programming](#), available on the website.
- Both the software application and the [manual code. 97830 Manual software display extra](#), are available on our webpage.

### Mapping from the keypad + display in digital outdoor panels

- Enter programming mode.
- Enable the alphanumeric keypad (in order to be able to write user names).
- Add users.
- Enable mapped calling.

#### a) ENTER PROGRAMMING MODE

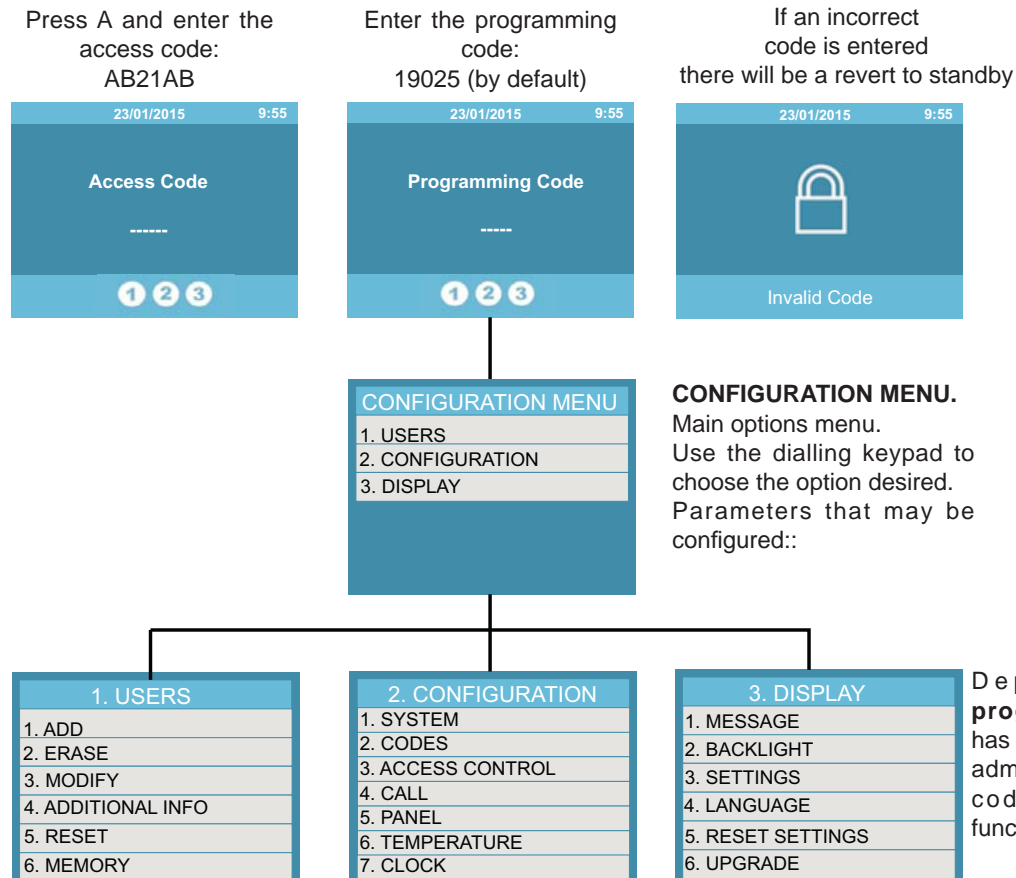

**b) ENABLE ALPHANUMERIC KEYPAD (in order to be able to write user names)**

**3. DISPLAY:** Enables the performance of settings relating to information from the display. Use the numeric keypad to select the desired configuration option.

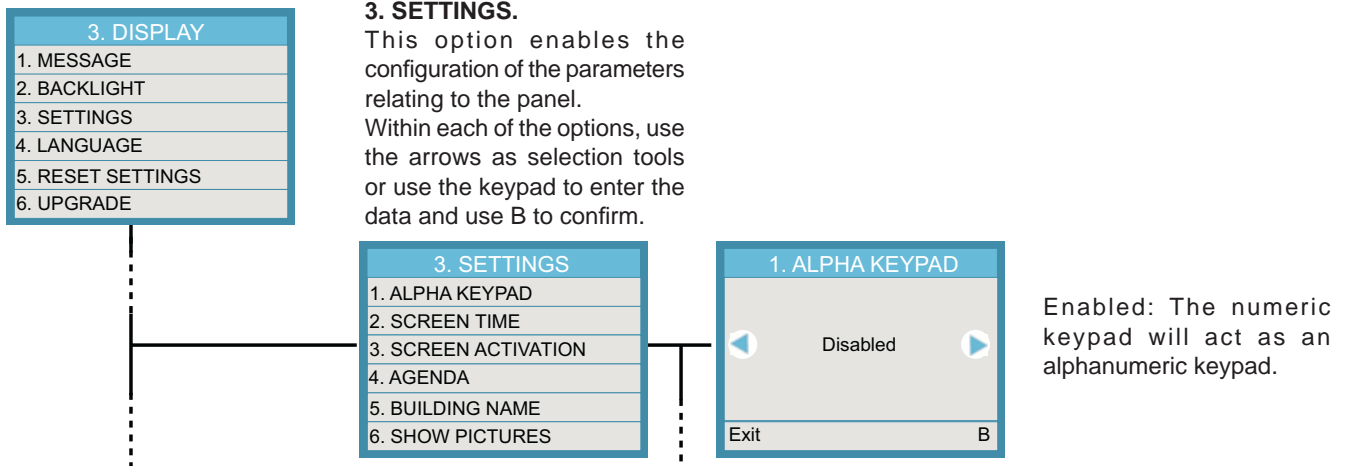

**c) ADD USERS**

**1. USERS:** Enables the configuration of the data of different users.

**1. Add:** Use the arrows to scroll through the different menus. Pressing B from any sub-menu saves the data and reverts to the USER menu.

- Apartment is the unmapped call.
- Call code is the mapped call.

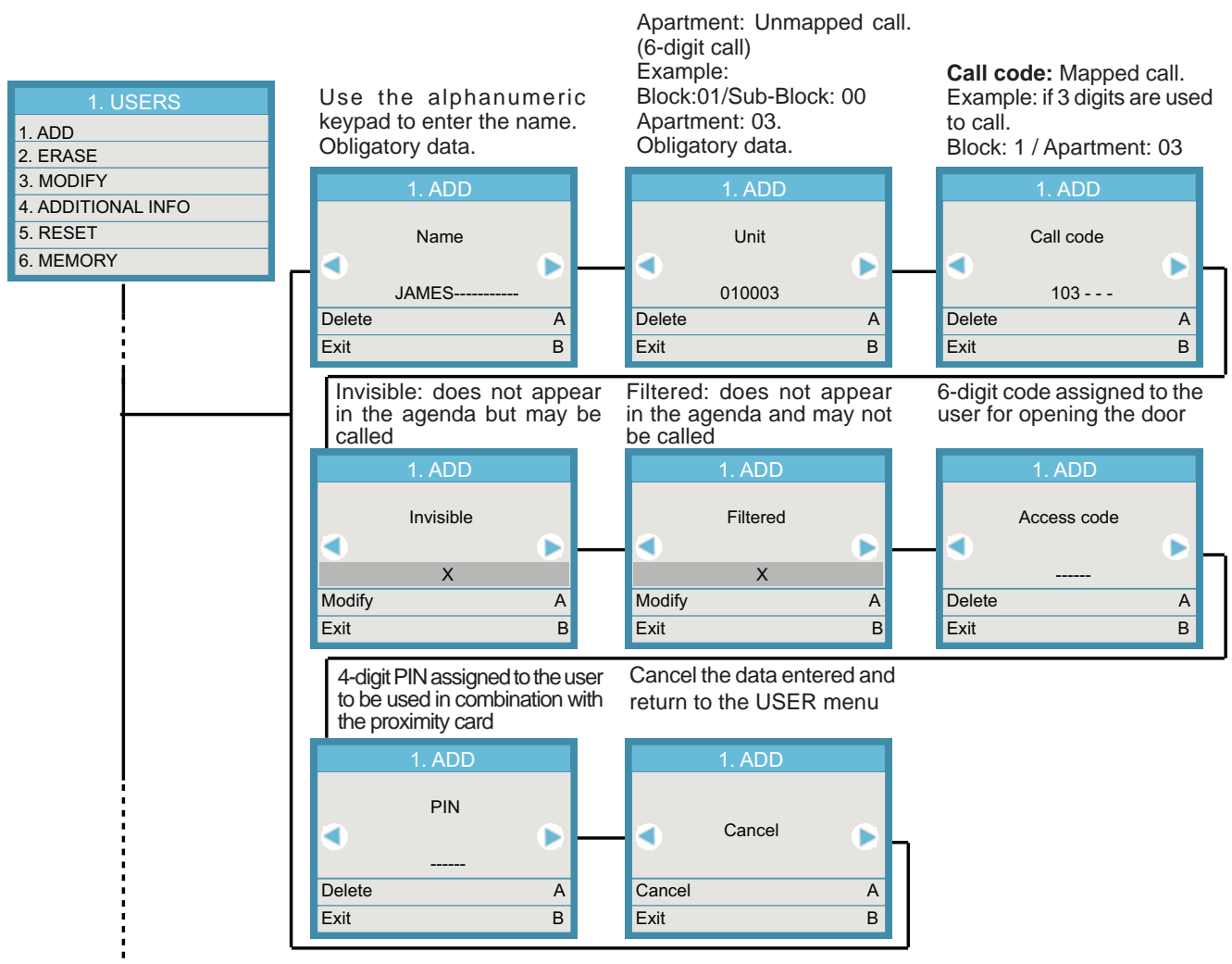

## d) ENABLE MAPPED CALLING

**2. CONFIGURATION:** This enables the setting of the parameters of the outdoor panels. Use the numeric keypad to select the desired configuration option.

2. CONFIGURATION
1. SYSTEM
2. CODES
3. ACCESS CONTROL
4. CALL
5. PANEL
6. TEMPERATURE
7. CLOCK

### 4. CALLING.

This option makes it possible to configure the manner in which calls are made to the apartments.

Within each of the options, use the arrows as selection tools or use the keypad to enter the data and use B to confirm.

4. CALL
1. CALL FILTER
2. CALL CODES

2. CALL CODES
Disabled
Exit B

Enabled: Enables the use of alphanumeric and mapped calls from the numeric keypad.

## 2.2.3 ADVANCED PROGRAMMING OPTIONS IN DIRECT OUTDOOR PANELS

### CHANGING THE DOOR RELEASE CODE (when this has already been enabled)

It is possible to change the door release code at any time using the keypad (if this has been enabled), without having to enter the configurations. This is convenient if you wish to allow neighbours this change.

The door release code can be changed using the following sequence:

**A + 3141 + Current Code** (4 digits) + **New Code** (4 digits)

If the change is correct a confirmation tone will sound (beep-beep) and if the change is not correct an error tone will sound (bop-bop). In this case it is not possible to enter any digit with the value "A" as a "New Code".

### RESTORING THE PROGRAMMING ACCESS CODE (in the event that the latter is forgotten)

If the programming access code has been forgotten, it can be restored to the default setting.

The following steps must be performed:

1. With the power supply disconnected, create a short circuit between the "Bs" and "-" (negative) terminals of the amplifier (or press the exit button if applicable).
2. Maintaining the previously-mentioned short circuit, connect the power supply of the system.
3. The outdoor panel will respond with the default code (4444) and a "beep-beep" tone will sound.
4. From then on, the short circuit between terminals "Bs" and "-" may be removed and the amplifier may be used as normal.

*Note: If there is a situation in which the door release code has been assigned the same code as the default enter programming mode code, when the access code for programming is restored the access code of the door release will be immediately deactivated. This is due to the fact that the two fields of the programming parameters cannot have the same programming code.*





### 3. DUOX AUDIO GUARD UNIT

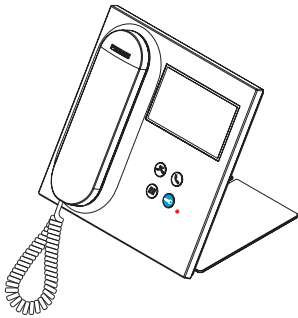

The DUOX system can be complemented with one or more GUARD UNITS (in the general entrance and/or in internal blocks) which can be wall-mounted or desk-mounted.

The central unit of the guard unit acts as a “filter” between residents of a building and visitors.

The VEO DUOX guard unit includes a 4.3” touch screen with which users may navigate through the different guard unit screens. Navigation may be performed via the icons, and selections made by pressing on the screen.

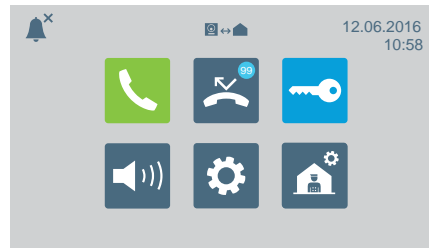

#### Notes:

- It is also possible to refrain from employing the outdoor panel as long as there is at least 1 Guard Unit.
- For more information, [consult manual code 970034 DUOX Audio Guard Unit Manual](#).

The guard unit includes 3 operation modes: Day, Combined and Night.

The modes which are available are:



#### DAY Mode

All of the calls from outdoor panels are intercepted by the guard unit.

The apartments/outdoor panels can call the guard unit directly.



#### MIXED Mode

The call sounds in the apartment. If there is no response within 15 seconds the call will also sound in the guard unit.

From then on, the guard unit may pick up the call and it will cease to sound in the apartment, or vice versa.

The apartments/outdoor panels can call the guard unit directly.



#### NIGHT Mode

The guard unit will not receive calls of any kind.

*Note: The mode that has been selected will appear on the main menu screen.*

#### 1. CONTROL BUTTONS

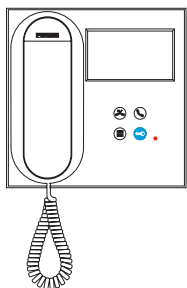

Direct access buttons to missed calls



Direct access button to communication



Menu button

1. In standby mode the main menu is accessed.
2. When active, if in the main menu the screen will shut down. In any other screen it will revert to the main menu.



Lock release button

Press to open the door while in conversation or on the “Door Release” screen.

## 2. OPERATION



### 2.1 SCREENS AND ICONS



COMMUNICATION

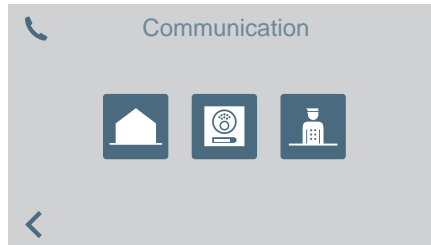

MISSED CALLS

Date	Hour	Unit
01/02	17:10	010003
01/02	11:25	010002
01/02	09:37	020001
01/02	08:45	040008



OPEN DOOR

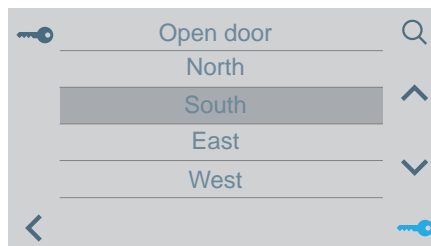

CALL VOLUME

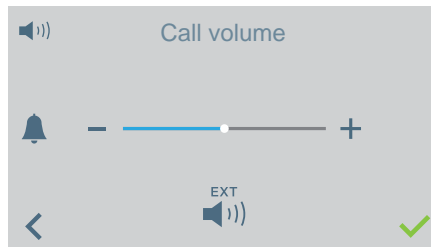

SETTINGS

Via this icon it is possible to go to the Settings menu:

- Date and time.
- Touch volume.
- Melody selection.
- Brightness.
- Block screen.
- Parameters (Administrator Menu).

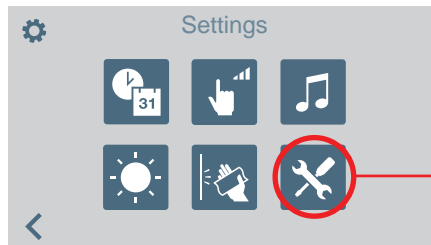

PARAMETERS  
(ADMINISTRATOR MENU)



The **Parameters** icon allows access to the administrator menu.

The Administrator Code (4444 by default) must be entered.

Options:

- Select language.
- Change passwords.
- Programme a terminal.
- Select the guard type.
- Directory settings.



SELECTING A GUARD UNIT MODE

Selection of the guard unit mode. Enter the concierge password, which by default is 1111.

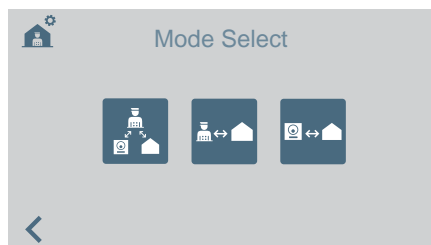

### 2.2 LED SIGNALLING

The guard unit includes an LED:

Switched on: Guard unit with power supply in standby mode (screen shut down).

Shut down: Guard unit with screen switched on or without power supply.

Blinking: Missed calls.

### 3. CONNECTION TERMINALS, TECHNICAL SPECIFICATIONS AND DEFAULT VALUES

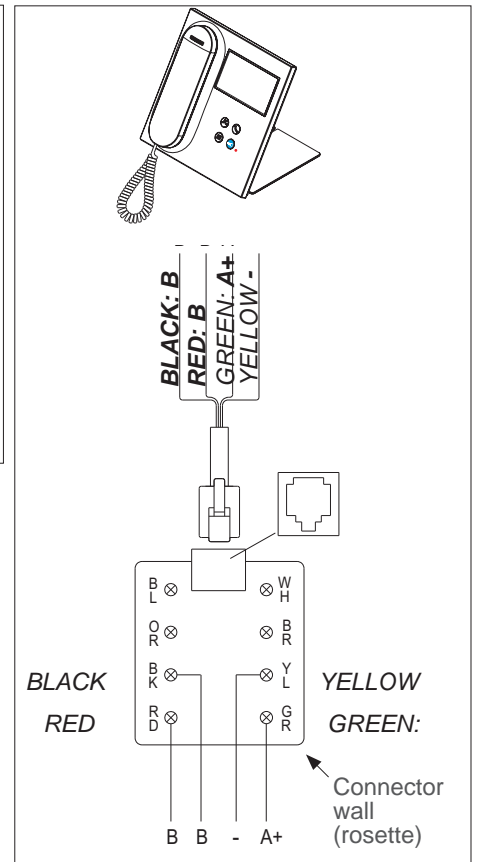
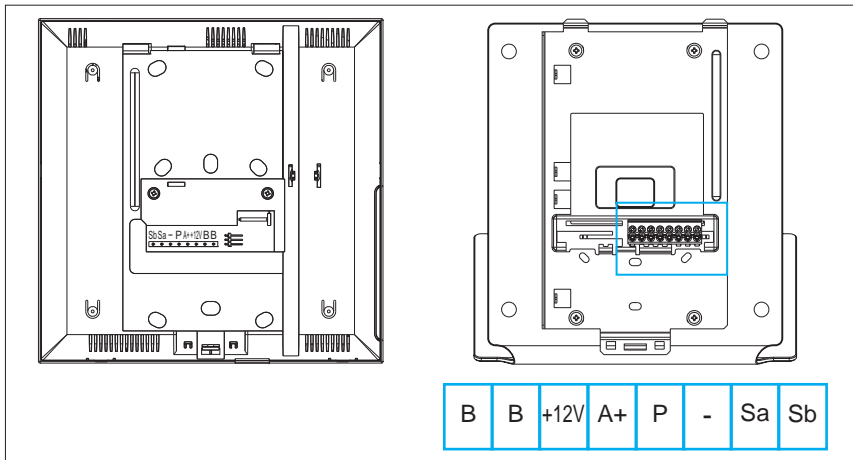

#### Terminals

**B, B:** DUOX Bus.

**+12V:** +12 Vdc output. Not in use.

**A+, -:** Electronic Extension Call Repeater ref 2040 / VDS Light / Buzzer Activator Ref. 2438.

**P:** Panic alarm input. Not in use.

**- :** Negative.

**Sa, Sb:** Bus RS485. Not in use.

#### Technical Specifications:

Power supply	18 Vdc
Standby consumption	63 mA
Call consumption (maximum volume tone)	435 mA
Number of guard units per installation	10 in General Entrance / 10 per Block
Operating temperature	[-5°, +40°C] / [-23°, 104°F]
OSD Screen	TFT 4.3"
Resolution	Hor: 480 Line TV / Ver: 272 Line TV
Monitor dimensions (excluding support):	200 x 200 x 46 - 8" x 8" x 1.8" (Height x Width x Depth)

#### Default values

Language	Spanish
Installer code	4444
Concierge code	1111
Encoding	
Block	
Block Number	00
Guard Unit Number	0
Brightness	4
Time and date format	DD/MM/YYYY and 24 hours
Call volume	4
Vibrate volume	0
Conversation volume	4
Melody	BLEEPER
Guard unit mode	Night
External bell output	Disabled

## 4. POWER SUPPLY SET: POWER SUPPLY + DUOX FILTER

The DUOX system has a power supply with a voltage of 18Vdc.

The power supply that should be used is: Ref. 4830 Power supply 18Vdc/3.5A.

The power supply cannot be connected directly to the bus, given the DUOX System features, as the power supply and the data travel along the same wires.

The power supply requires DUOX filter ref. 3244. This module prevents the power supply from interrupting the operation of the rest of the signals circulating through the system. Similarly, this module will be used to connect more sources if required by the system.

The power supplies must always be accompanied by DUOX filter ref. 3244. We refer to the combination of the power supply and the filter as the "Power Supply Set".

The DUOX filter must be connected directly to the bus with the shortest possible cable length.

The distance between the power supply set and the last terminal that it supplies will depend on the type of cable, the topology of the installation and the model of the apartment terminals.

**Notes:**

- The power supply set is not necessary with the DUOX 2S Regenerator (ref. 3253), as this device has a filter included. This means that this regenerator need only receive its power supply from the source.
- Extensions of terminals within the same apartment will also require a power supply set. A maximum of 3 terminals may be installed in each apartment.

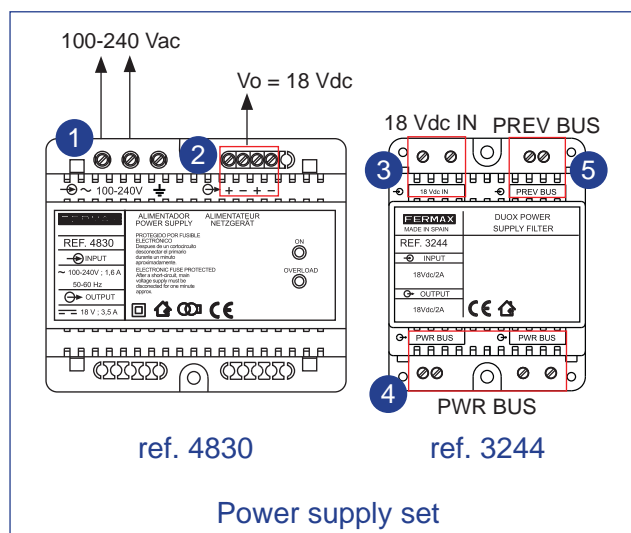

**ref. 4830**

- 1 100-240V: Input voltage  
100 ~ 240 Vac.  
Input frequency: 50 ~ 60 Hz.
- 2 +, -: Output voltage  
18 Vdc ±2%.  
Output current: 3.5 A.

**ref. 3244**

- 3 18 Vdc IN: Power supply connection  
18 Vdc, non-polarised
- 4 PWR BUS: Bus connection  
Duplicated terminal for ease of installation.
- 5 PREV BUS:  
Bus input with voltage from another source.  
Bus output without voltage for another device which has a power supply.

**Connection of various sources**

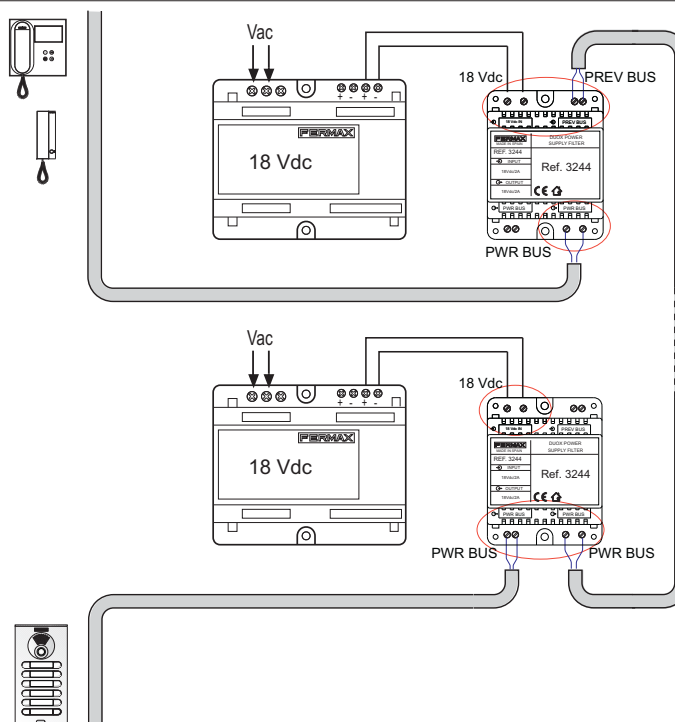

## 5. DUOX LINE ADAPTER

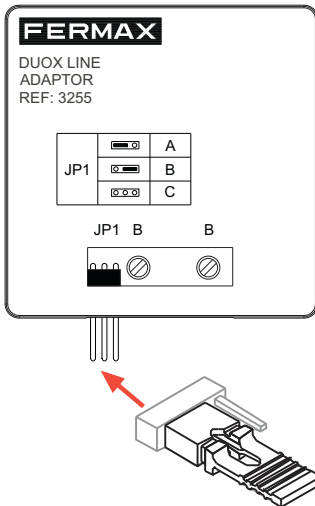

With the DUOX system it is necessary to adapt the transmission line. Line adapter ref. 3255 can be used for this purpose.

There are also other devices that include a line adapter in their structure.

This adapter balances impedances in the transmission line. This is a small element (44 x 44 x 26 mm / height x width x depth). The location and configuration of the element depend on the topology of the installation (number of risers, additional elements and so on).

We will now provide instructions about how to install and how to configure the line adapters in a suitable manner.

5.1 Devices that include a line adapter in their structure.

5.2 Where to install the adapter and how to configure it.

### 5.1 DEVICES WHICH INCLUDE A LINE ADAPTER IN THEIR STRUCTURE

In addition to Line Adapter ref. 3255, other DUOX devices can also be used as line adapters:

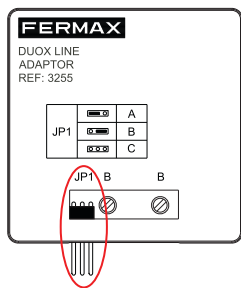

#### LINE ADAPTER (Ref.3255)

Includes a jumper (JP1) which enables configuration as “C” or “A”. The device includes a connection terminal to be installed in parallel with the cable of the installation. The default configuration is “C”.

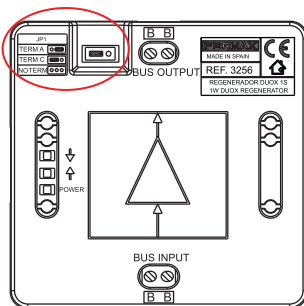

#### 1S REGENERATOR (Ref.3256)

Line adapter integrated to the (BUS INPUT) input, with configurable adaptation (“C”, “A” or “no adaptation”) using jumper JP1. The default configuration is “C”; if no adaptation is required, remove the jumper (NO TERM).

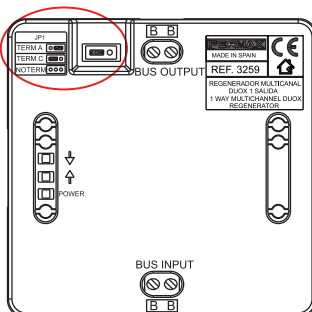

#### 1S MULTI-CHANNEL REGENERATOR (Ref.3259)

Line adapter integrated to the (BUS INPUT) input, with configurable adaptation (“C”, “A” or “no adaptation”) using jumper JP1. The default configuration is “C”; if no adaptation is required, remove the jumper (NO TERM).

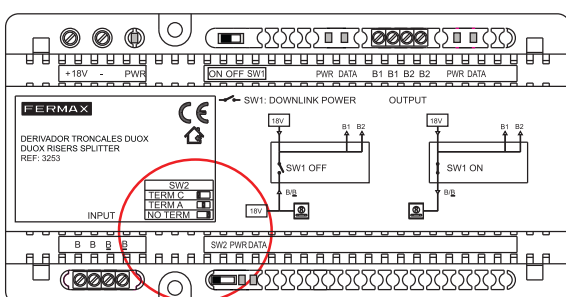

#### 2S REGENERATOR (Ref.3253)

Line adapter integrated to the (B, B) input, with configurable adaptation (“C”, “A” or “no adaptation”) using switch SW2. The default configuration is “NO TERM”; if no adaptation is required, leave the SW2 switch in the default position (NO TERM).

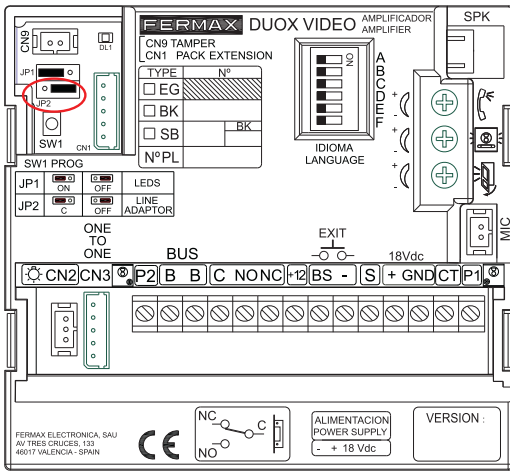

### VIDEO AMPLIFIER

Line adapter integrated to the output bus, with configurable adaptation (“C” or “no adaptation”) using jumper JP2. The default configuration is “no adaptation” (OFF).

*Note: DUOX audio amplifiers do not have an integrated line adapter.*

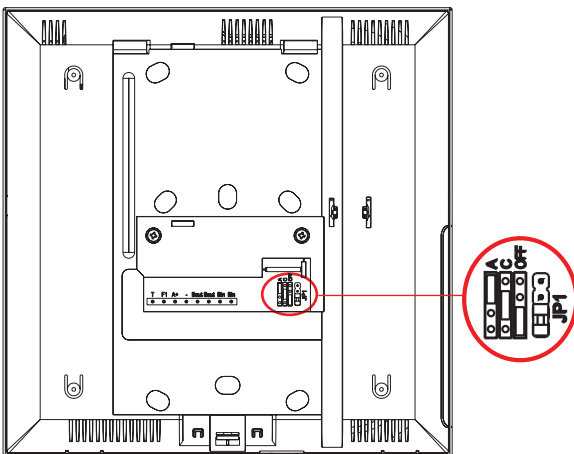

### VEO MONITOR:

Includes a JP1 jumper: Line adaptation bridge, which enables configuration as:

- Top: Adaptation type A.
- Centre: Adaptation type C.
- Bottom: Without line adaptation.

The default configuration is “no adaptation” (OFF).

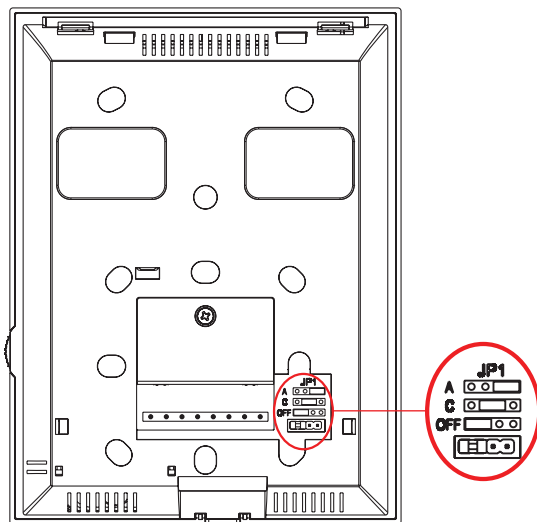

### VEO XS Monitor

Includes a JP1 jumper: Line adaptation bridge, which enables configuration as:

- Right: Adaptation type A.
- Centre: Adaptation type C.
- Left: Without line adaptation.

The default configuration is “no adaptation” (OFF).

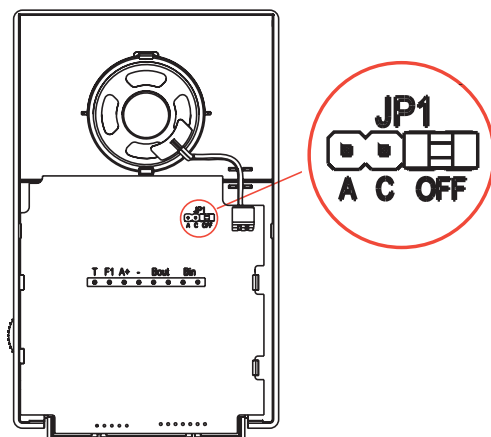

### iLOFT TELEPHONE

Includes a JP1 jumper: Line adaptation bridge, which enables configuration as:

- Right: Without line adaptation.
- Centre: Adaptation type C.
- Left: Adaptation type A.

The default configuration is “no adaptation” (OFF).

## 5.2.WHERE TO INSTALL A LINE ADAPTER AND HOW TO CONFIGURE IT

### VIDEO INSTALLATIONS

Generally speaking, when working with video installations we can state that adapters are always installed at the beginning and at the end of the riser, but the place in which the adapters should be situated will depend slightly on the number of risers and on whether the installation is in cascade format or whether it involves several terminals per derivation point.

*Note: In mixed installations (audio + video) the adapters should be installed in the same way as in the video installations.*

#### a) In cascade installations:

- One riser: position a line adapter at the first terminal and another line adapter at the last terminal.
- More than one riser: place a line adapter at the fork and a line adapter at the last terminal of each riser.
- All adapters **are configured** as “C”.

*Note: Depending on the type of installation, if possible the line adapter included in certain devices may be used. In this case, the one from the monitor.*

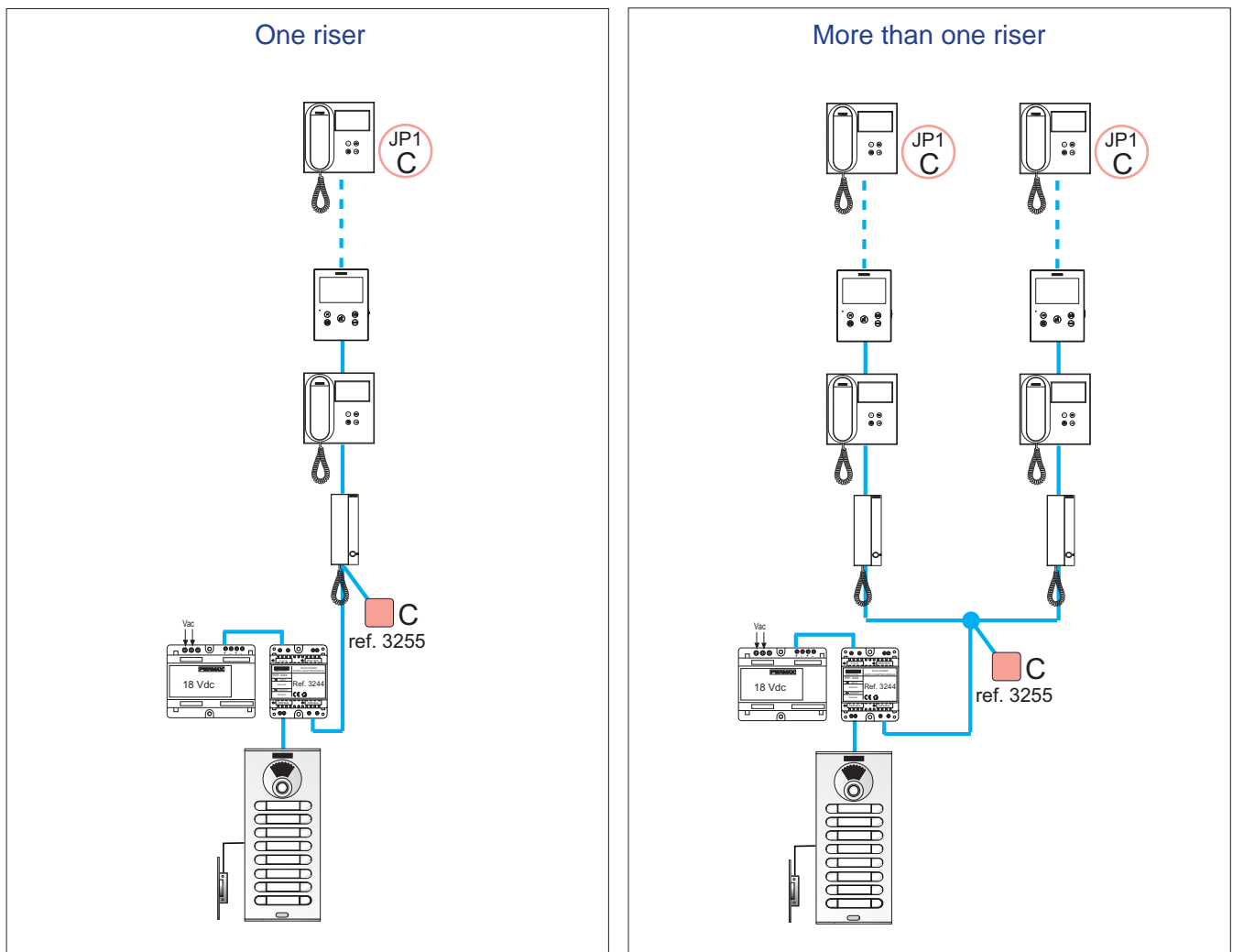

#### b) In installations with several terminals per storey:

- One riser: place a line adapter at the first storey fork and another line adapter at the last storey fork.
- More than one riser: place a line adapter at the first fork and another line adapter at the furthest fork from each riser with respect to the outdoor panel.
- The adapters **are configured**:
  - \* At the first fork, starting from the outdoor panel, configure the adapter as “C”.
  - \* At the last fork of each riser, configure the adapter in “A” (the furthest away with respect to the outdoor panel).

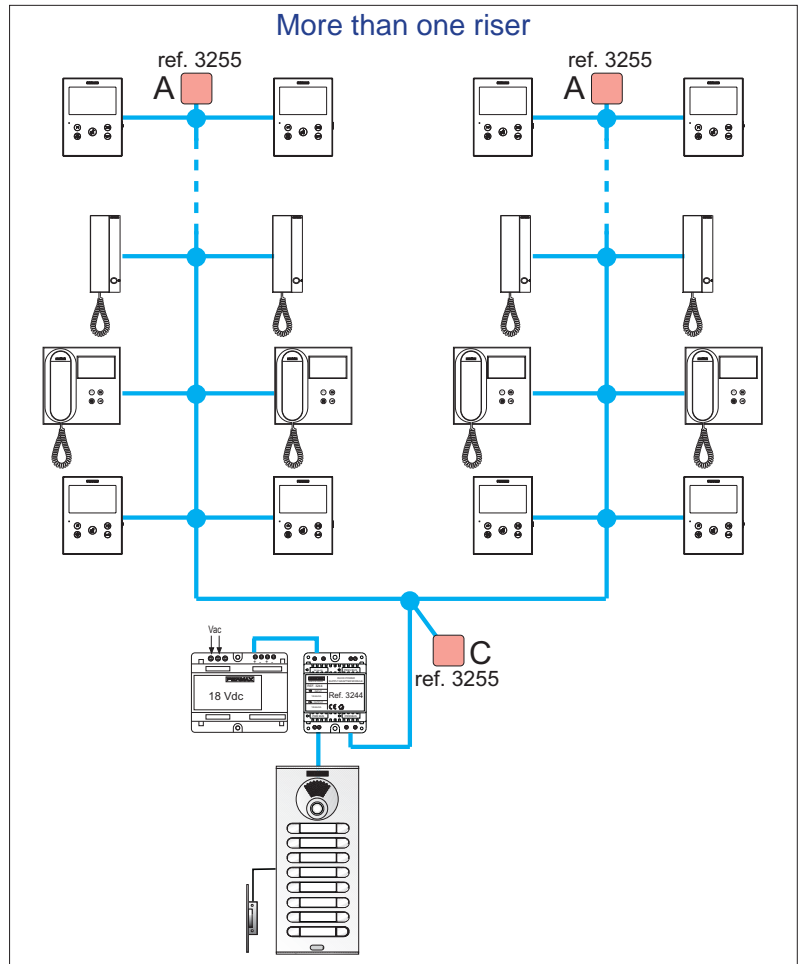
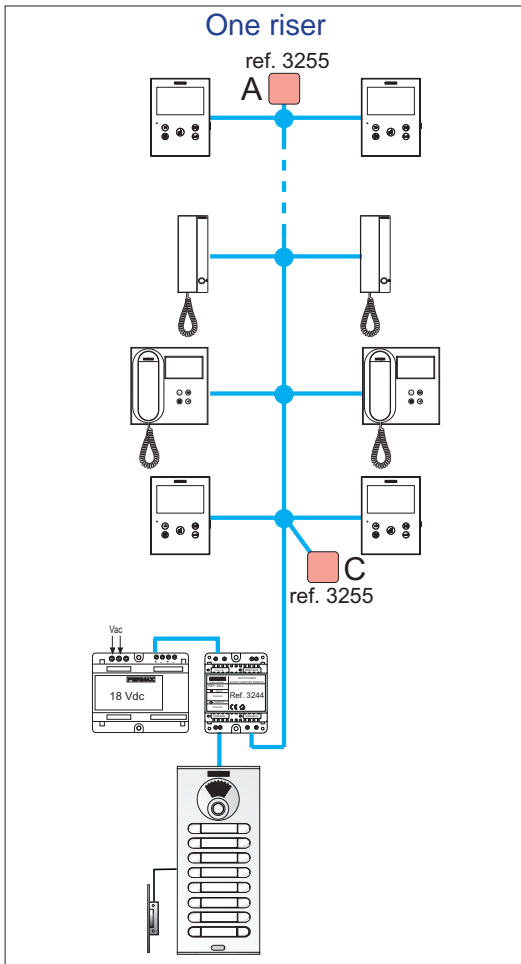

- c) In the specific event that a bus has no terminals (for example, when there are regenerators and the bus that joins these has no telephone or monitor connected).
- In this case, one adapter is connected at the beginning of the bus and another is connected at the end.
  - The adapters are configured as "C" at the beginning and at the end of the bus.

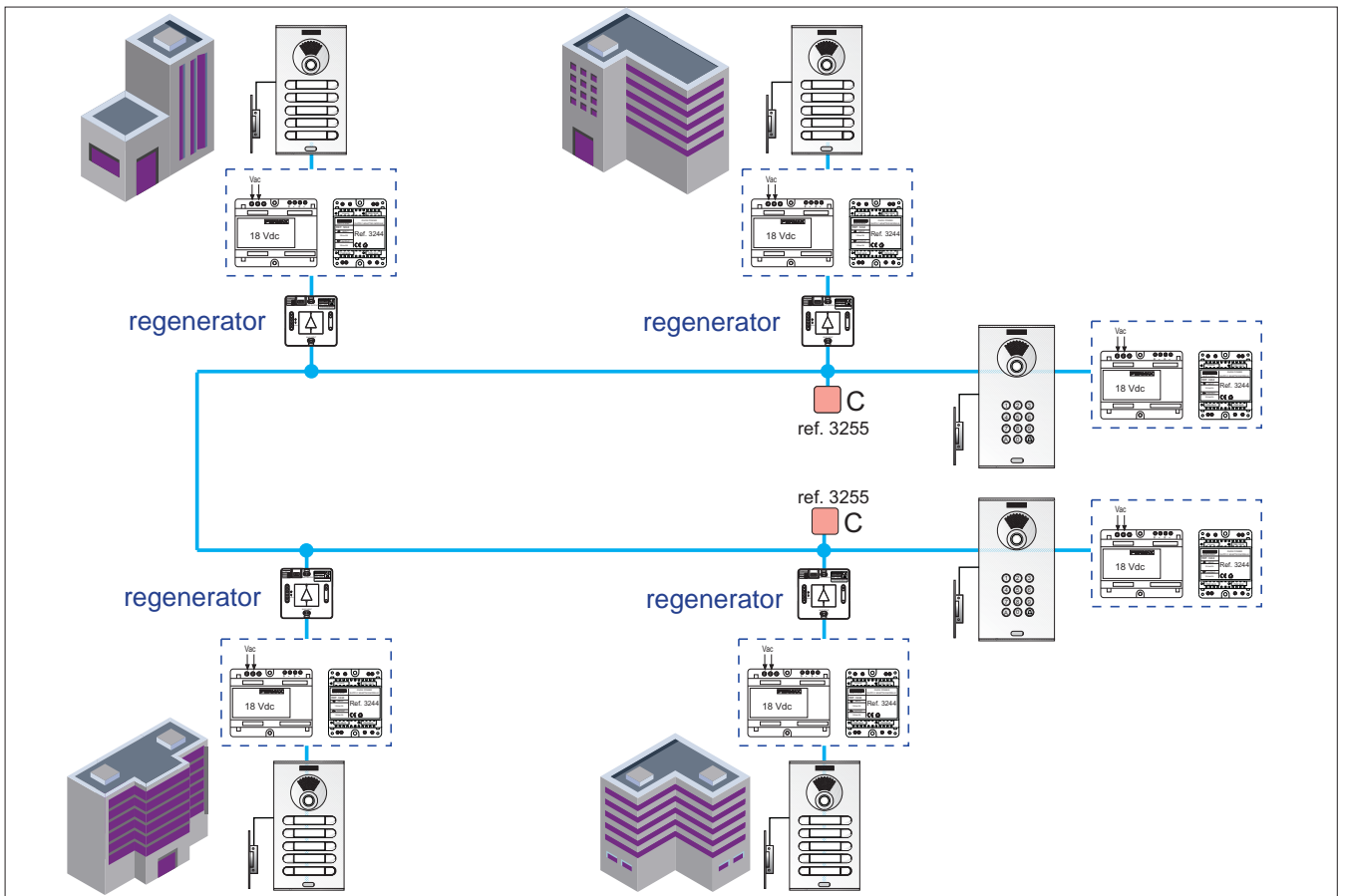



## AUDIO-ONLY INSTALLATIONS

Generally speaking, when dealing with audio installations we can state that the adapters are always installed at the end of the riser.

### a) In cascade installations:

- One riser: place a line adapter at the last terminal.
- More than one riser: place a line adapter at the last terminal of each riser.
- All adapters **are configured** as "A".

*Note: Depending on the type of installation, if possible the line adapter included in certain devices may be used. In this case, the one from the iLOFT telephone.*

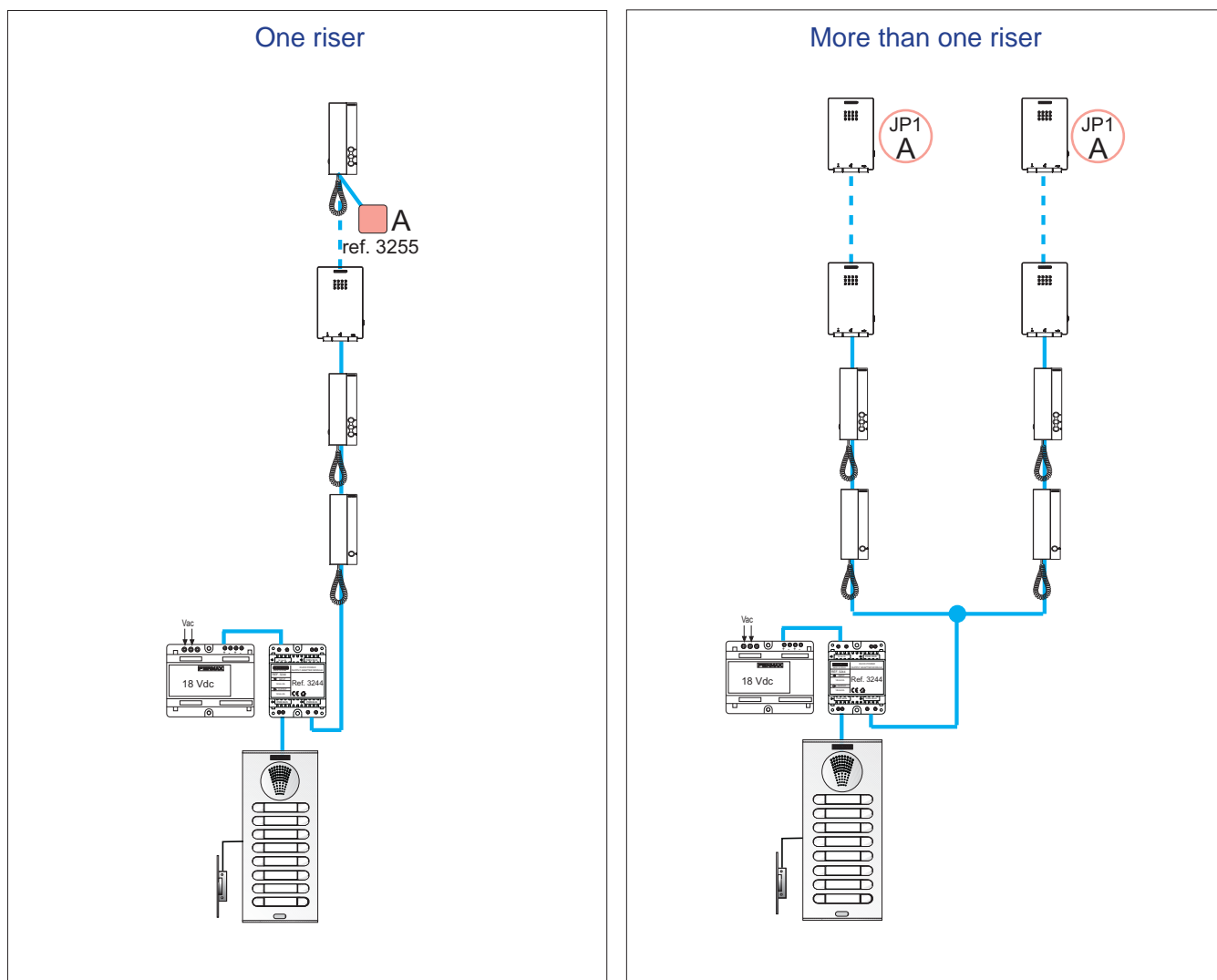

### b) In installations with several terminals per storey:

- One riser: place a line adapter at the fork of the last storey.
- More than one riser: place a line adapter at the furthest fork from each riser with respect to the outdoor panel.
- The adapters **are configured**:
  - \* All adapters **are configured** as "A".

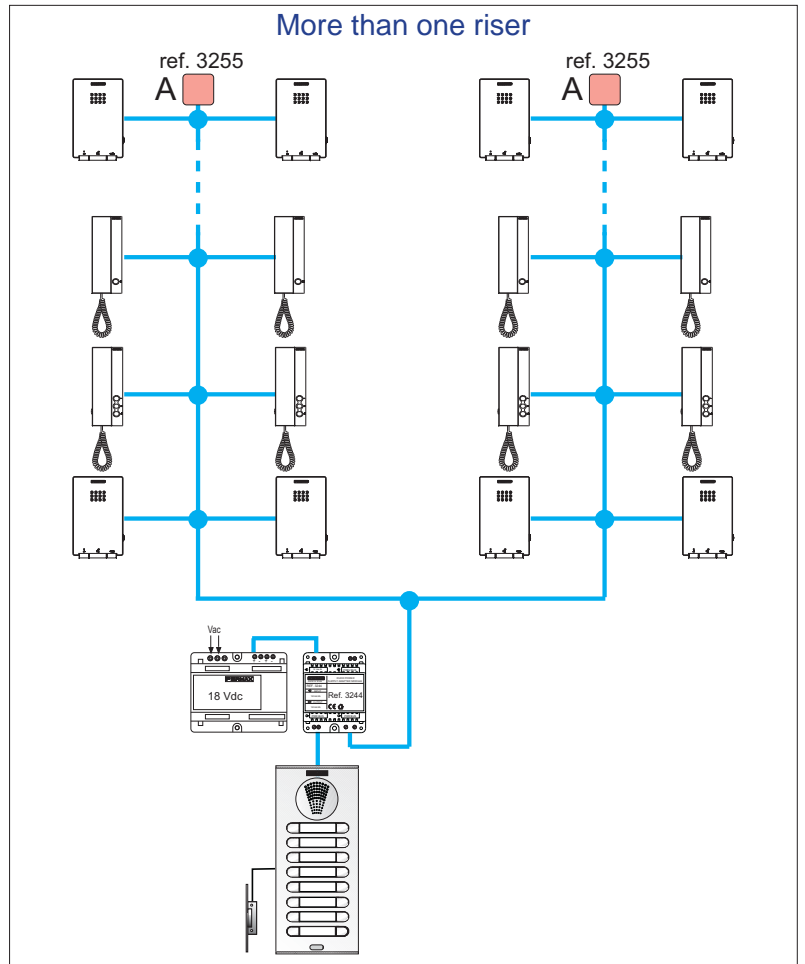
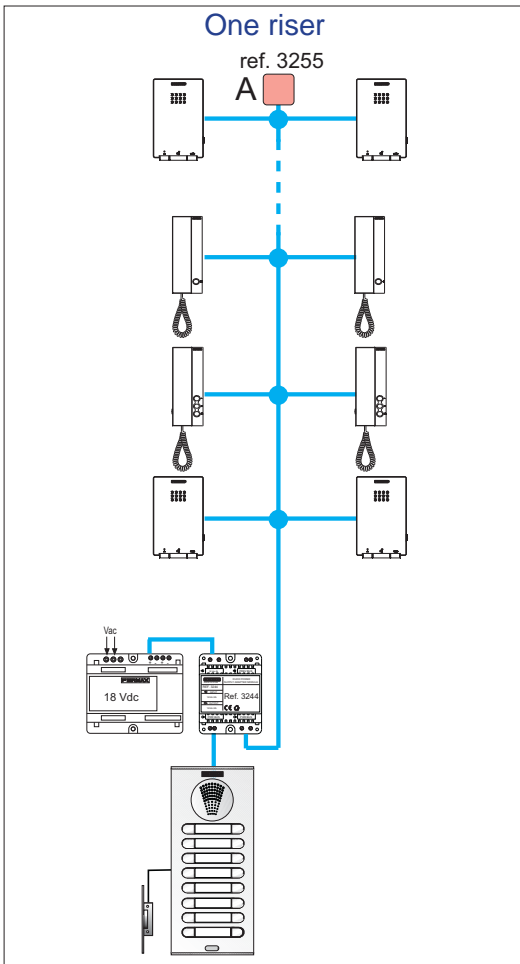

- c) In the specific event that a bus has no terminals (for example, when there are regenerators and the bus that joins these has no telephone connected).
- In this case, one adapter is connected at the beginning of the bus and another is connected at the end.
  - The adapters are configured as "C" at the beginning and at the end of the bus.

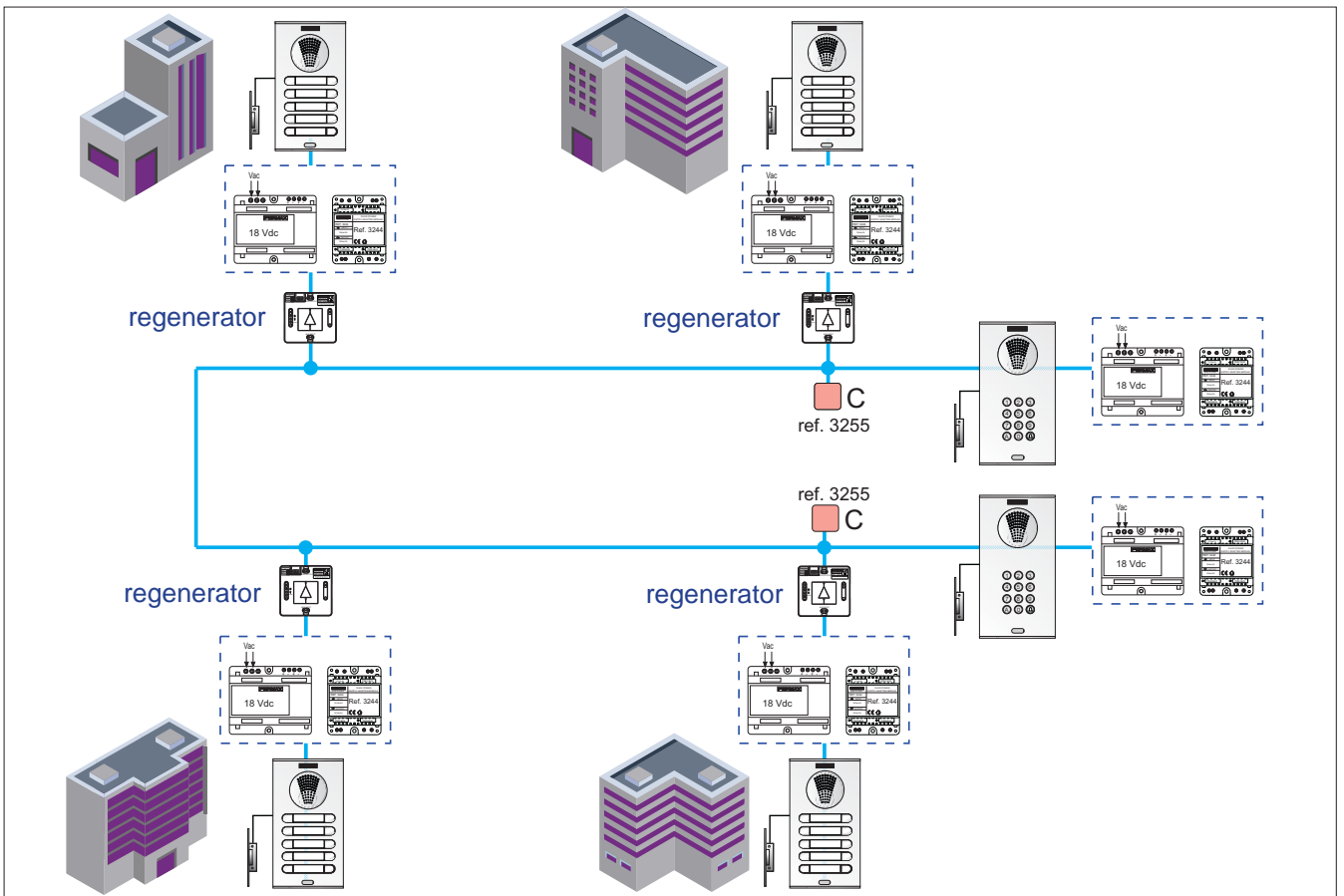

## 6. DUOX REGENERATOR

This element is capable of completely regenerating the DUOX signal. As it works in both directions, it does this both in the input-output direction and in the output-input direction. As well as regenerating the signal, it also electrically isolates the sections of the installation to which it is connected.

The main function and purpose of a regenerator is to increase distances, risers and terminals in an installation.

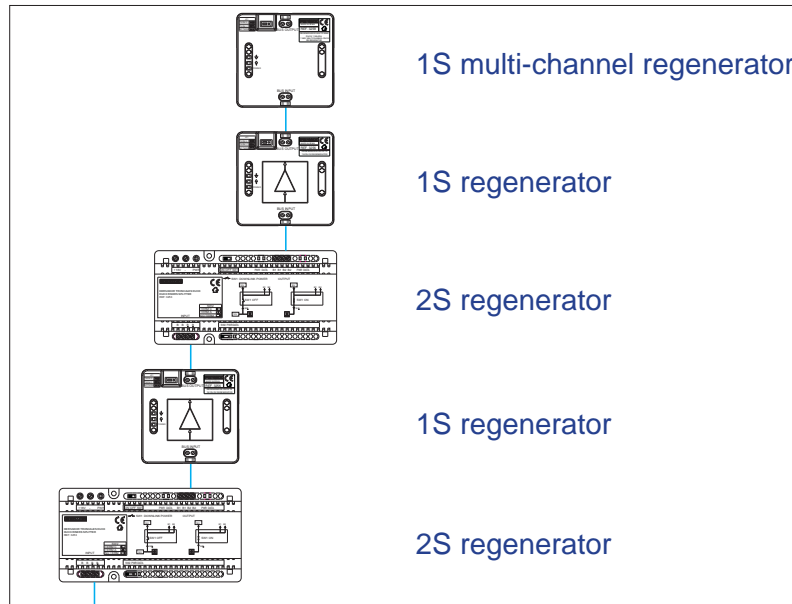

As many generators may be used as is necessary in parallel installation, keeping in mind that the maximum number of regenerators that can be installed in series is 5 (different models can be combined).

It is only possible to use the regenerator in points of the installation at which the signal quality is sufficiently strong to connect a monitor, or a telephone in audio-only installations, and at which the quality of communication is high in both directions.

It is important to remember that if several risers have been connected in parallel at the output of a regenerator, these will be isolated with respect to the input but they will not be isolated from one another.

The regenerator also includes an **integrated line adapter in its input** (see section 5.1 *Devices that include a line adapter in their structure.*), which may be used or not, depending on whether this is necessary, following the criteria for the use of the line adapter. This integrated line adapter can be configured as “A”, “C” or “no adaptation”. When installing a regenerator, it will be necessary to include the line adapters following the general installation criteria.

There are different regenerator models to meet the particular requirements of each installation. Next we will outline the different models, particular features and user recommendations for each of these.

### 6.1 DUOX 1S REGENERATOR (REF. 3256)

Includes 1 input and 1 output. Supplied with power from the DUOX bus from either of the two sides.

The 1S regenerator regenerates data, but it does not allow the power supply to pass, which means that the sections from both sides require their own power supply set. In addition to this, the sections connected to the input and output are protected against short circuits, load and signal reflections.

It is only in the event that there are no terminals between the regenerators that a power supply set will not be needed.

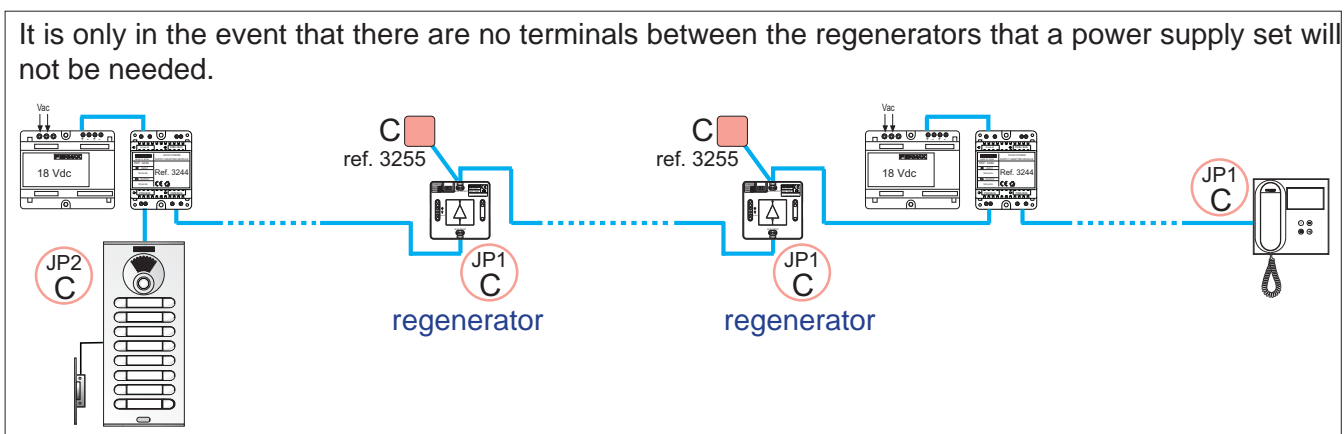

The INPUT/OUTPUT terminals can be connected interchangeably in an installation (regeneration happens in both directions). However, only the INPUT terminal has an incorporated line adapter (configurable using JP1), which means that the orientation of the regenerator should be determined by the installer, in order to benefit from the incorporated termination based on the topology.

**It is advisable to use the DUOX 1S regenerator:**

- To increase the distance from the outdoor panel and the power supply set (See Diagram 1).
- To increase the number of terminals in the installation (See Diagram 2).
- In order to increase the distance between the outdoor panel and terminals, or in a branch.
- When it is advisable or necessary to isolate sections from one another, for example:
  - when there is a complex topology.
  - at a change of section or cable type.

Diagram 1

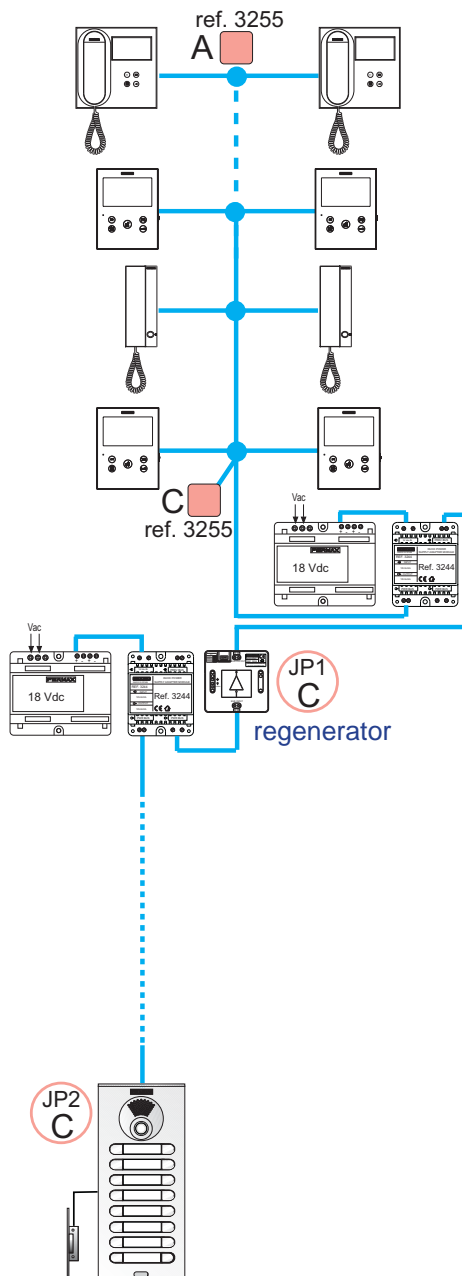
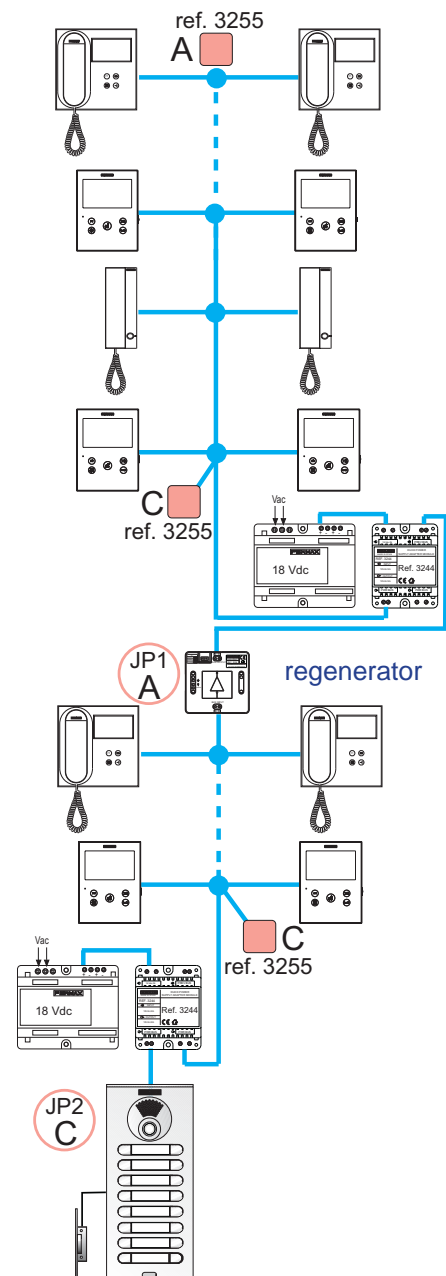
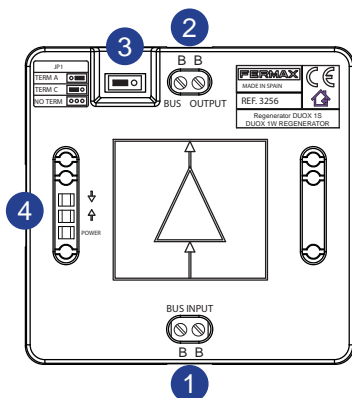

Diagram 2





- 1 B B: BUS INPUT connector  
DUOX Bus
- 2 B B: BUS OUTPUT connector  
DUOX Bus
- 3 JP1: Integrated line adapter (to the input: BUS INPUT connector)
  - Right: Adaptation type A.
  - Left: Adaptation type C, (by default).
  - Without bridge: Without line adaptation: NO TERM.
- 4 LEDs  
POWER (red): If the light is on, the power supply is correct.  
« $\uparrow$ » / « $\downarrow$ »: (green) If the light is on, data are being transmitted in the direction indicated by the arrow.  
During the communication with a terminal, both LEDs will be on at the same time.

### Technical Characteristics:

Power supply	18 Vdc
Active consumption	215 mA (max)
Operating temperature	[-5° , +40°C] / [23° , 104°F]
Dimensions	89 (H) x 86 (V) x 26 (P) mm
Minimum data signal without rippling	1 Vp
The set-up process can be completed using either a screw fitting or a DIN carril installation	

## 6.2 DUOX 2S REGENERATOR (REF. 3253)

Includes 1 input and 2 outputs.

Electrically isolates the three segments of the installation to which it is connected (the input and outputs). If several risers are connected in parallel in one of the outputs of the 2S regenerator, these will not be isolated from one another.

Power is supplied by a local source (in the absence of filter ref. 3244).

It is possible to use this power supply to provide current to other elements of the installation following two methods:

- a) Riser-only power supply mode: the power supply will reach each one of the risers. Switch: SW1 OFF.
- b) Risers + panel power supply mode: the power supply reaches each one of the risers and also the outdoor panel (in the event that there is no local power supply to the outdoor panel). Switch: SW1 ON.

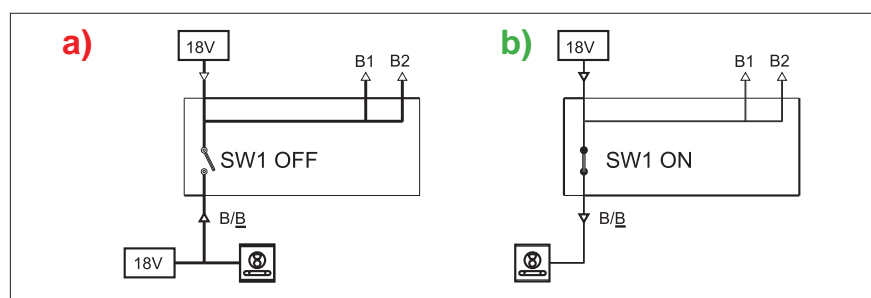

### It is advisable to use the DUOX 2S regenerator:

It is advisable to use the DUOX 2S regenerator in the same situations in which the 1S regenerator is used and also:

- In the event that it is necessary to separate or increase the number of risers (See Diagram 1).
- In the event that it is not possible to install a power supply to each section of the installation, since the 2S regenerator enables the passing on of the power supply (See Diagram 2).

Diagram 1

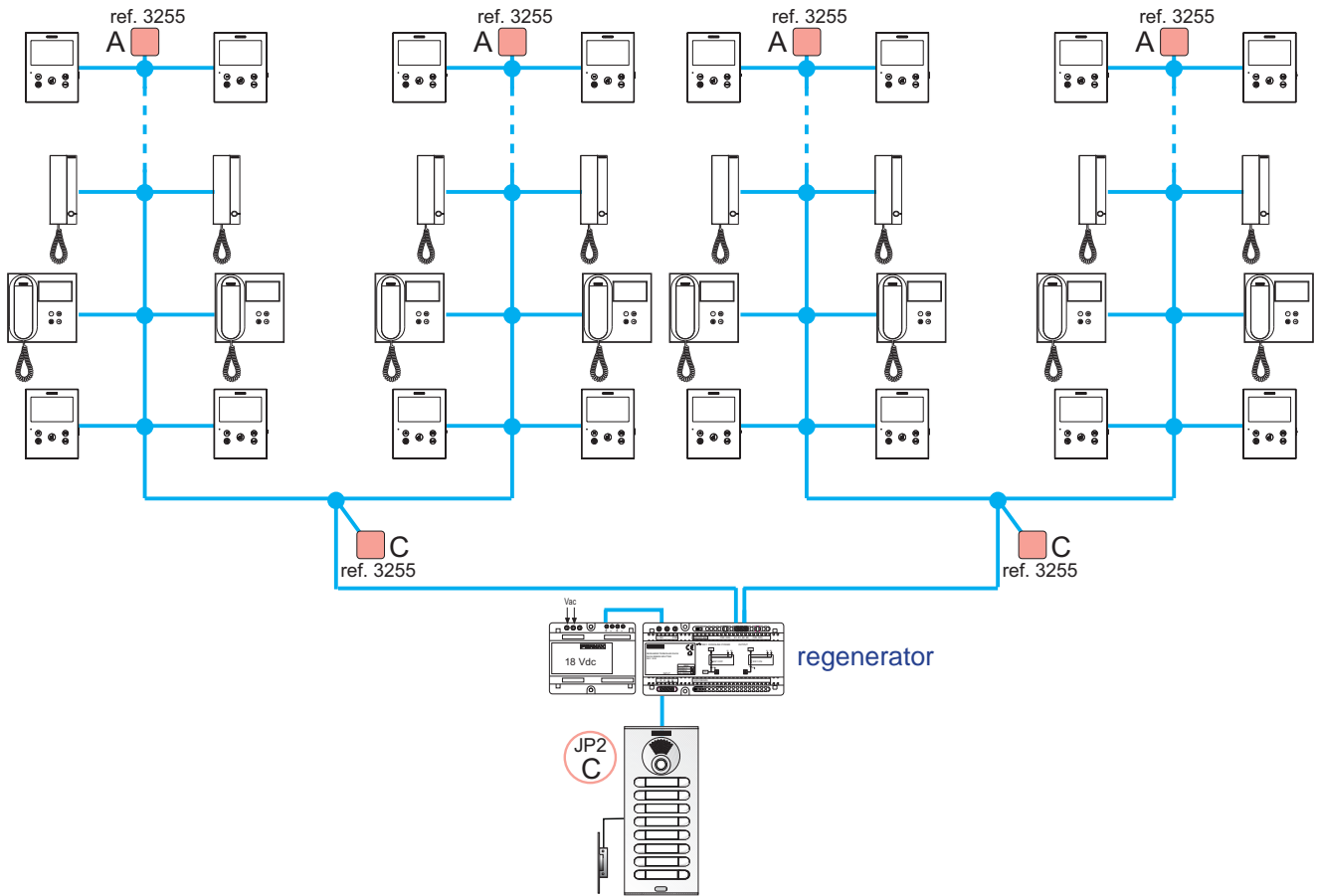
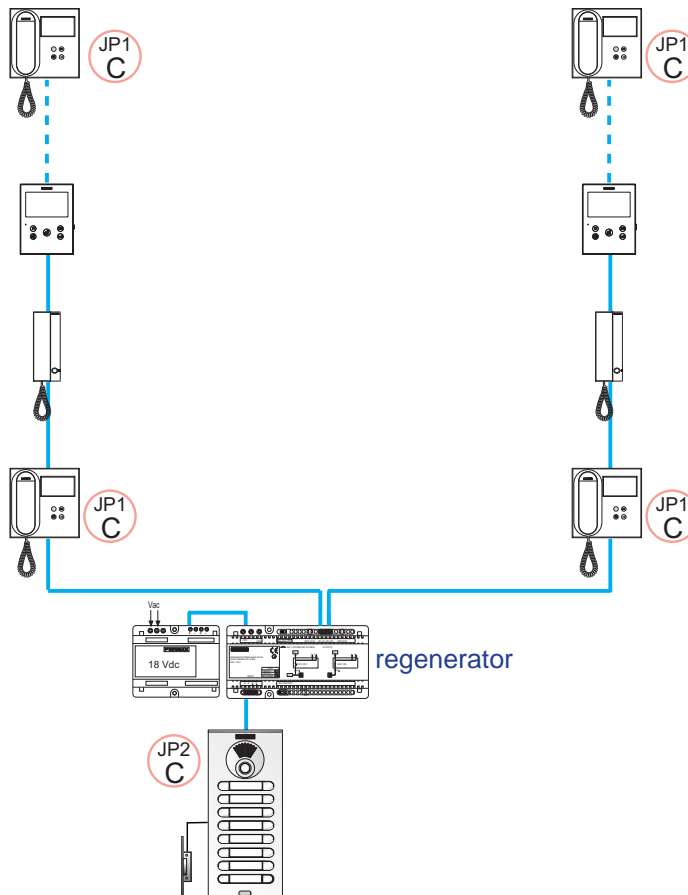
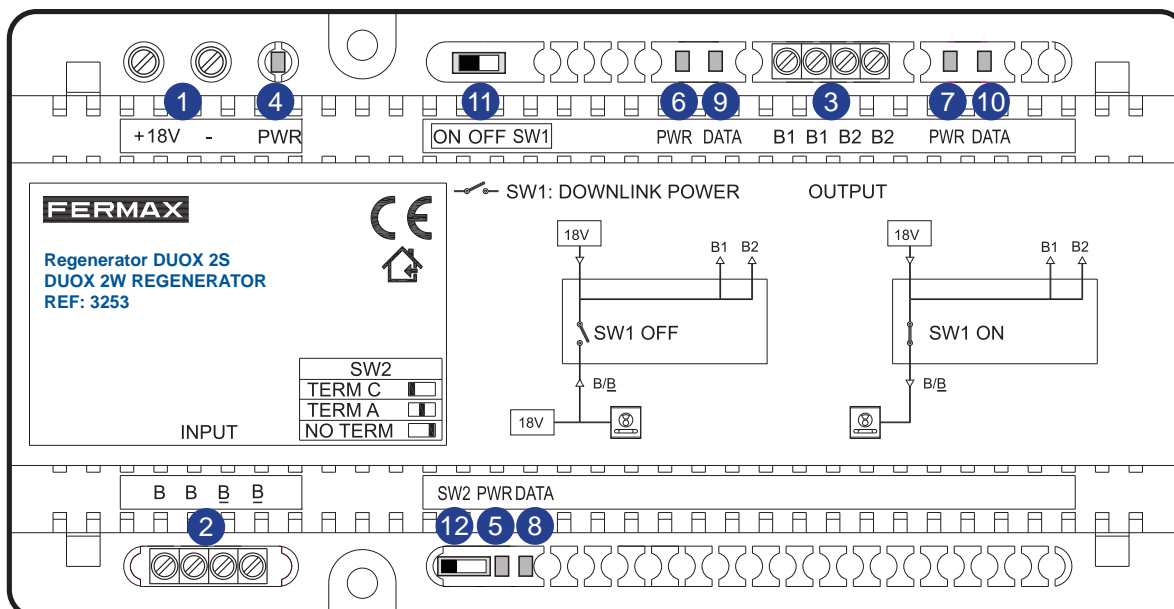

Diagram 2





## Connectors

- 1 +18V, - : 18 Vdc input power supply
- 2 B B: Terminals connecting the bus of the input riser.  
B B: Duplicate terminals connecting the bus of the input riser  
Facilitates connectivity in parallel.
- 3 B1 B1 Connection terminals of the input 1 riser  
B2 B2 Connection terminals of the input 2 riser

## Power supply signalling LEDs

- 4 PWR: Red LED light signalling the input of the power source  
ON: 18 Vdc input power supply.  
OFF: input power supply of less than 15.5 Vdc or in short circuit.
- 5 PWR: Red LED light signalling the presence of the power supply in the input riser  
ON: input power supply of greater than 15 Vdc.  
OFF: input power supply approximately lower than 15 Vdc or in short circuit.
- 6 PWR: Red LED light signalling the presence of the power supply in output 1 riser  
ON: input power supply of greater than 15 Vdc.  
OFF: input power supply approximately lower than 15 Vdc or in short circuit.
- 7 PWR: Red LED light signalling the presence of the power supply in output 2 riser  
ON: input power supply of greater than 15 Vdc.  
OFF: input power supply approximately lower than 15 Vdc or in short circuit.

## Data signalling LEDs.

These are associated with the transmission of data and can give us a visual indication of whether or not the input signal to the regenerator is sufficient.

While a call is being placed between the outdoor panel and the corresponding terminal, both LEDs should blink: the LED of the input riser [INPUT] and the LED of one of the output risers [OUTPUT].

During the communication from the outdoor panel to a terminal, the [OUTPUT] LED will shine continuously and the [INPUT] light will continue to blink. If the [OUTPUT] LED blinks during communication, this indicates that there is a loss of signal.

- 8 DATA: Green LED light signalling the presence of data in the input riser
- 9 DATA: Red LED light signalling the presence of data in the output 1 riser
- 10 DATA: Red LED light signalling the presence of data in the output 2 riser

## Switches (SW)

- 11 SW1: Switch for selecting the operating modes  
OFF: Riser-only power supply mode (a).  
ON: Risers + outdoor panel power supply mode (b).
- 12 SW2: Integrated line adapter (to the input), by way of a switch
  - Right: Without line adaptation: NO TERM (by default).
  - Centre: Adaptation type A.
  - Left: Adaptation type C.

### Technical Characteristics:

Power supply	18 Vdc
Consumption	130 mA
Operating temperature	[-5° , +40°C] / [23° , 104°F]
Dimensions	DIN 10: 175 (H) x 90 (V) x 60 (P) mm
Minimum data signal (without rippling)	1 Vp

The maximum direct current load during the start is 1 A.

## 6.3 DUOX 1S MULTI-CHANNEL REGENERATOR (REF. 3259)

Includes 1 input and 1 output. Supplied with power from the DUOX bus from either of the two sides.

The 1S multi-channel regenerator, just like the 1S regenerator, regenerates data, but it does not allow the power supply to pass, which means that the sections from both sides require their own power supply set. In addition to this, the sections connected to the input and output are protected against short circuits, load and signal reflections in a mutual manner.

The main feature and defining characteristic of the DUOX 1S multi-channel regenerator is that it makes it possible to create a communication channel in each one of the different blocks of the installation (simultaneous conversations).

It is designed to be used in installations with:

- A general entrance to several blocks with an outdoor panel in each one of these and/or
- A general entrance to family homes with an outdoor panel in each one of these

This regenerator generates an additional call channel per block or per family home. It is possible to simultaneously maintain as many conversations as blocks/family homes that have this regenerator and their own outdoor panel.

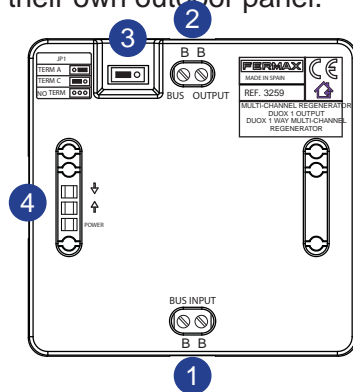

- 1 **B B: BUS INPUT connector**  
DUOX Bus: Connect to General Entrances
- 2 **B B: BUS OUTPUT connector**  
DUOX Bus: Connect to the corresponding Internal Block or Family Home.
- 3 **JP1: Integrated line adapter (to the input: BUS INPUT connector)**
  - Right: Adaptation type A.
  - Left: .Adaptation type C, (by default).
  - Without bridge: Without line adaptation: NO TERM.
- 4 **LEDS**  
POWER (red): If the light is on, the power supply is correct.  
«» / «»: (green): If the light is on, data are being transmitted in the direction indicated by the arrow.  
During the communication with a terminal, both LEDs will be on at the same time.

### Technical Characteristics

Power supply	18 Vdc
Active consumption	215 mA (max)
Operating temperature	[-5° , +40°C] / [23° , 104°F]
Dimensions	89 (H) x 86 (V) x 26 (P) mm
Minimum data signal without rippling	1 Vp

The set-up process can be completed using either a screw fitting or a DIN carril installation

### Programming (Addressing)

After connecting the DUOX 1 Output multi-channel regenerator, there will be an interval of 60 seconds in which its address may be programmed. In order to program the address, make a call using the outdoor panel of said block or using the auto switch-on from the monitor. The outdoor panel of the block must previously have been programmed with the parameters of the block number.

### It is advisable to use the DUOX 1S multi-channel regenerator:

- When 1 additional communication channel is required for the internal block or family home with the outdoor panel. (See Diagram 1).



Diagram 1

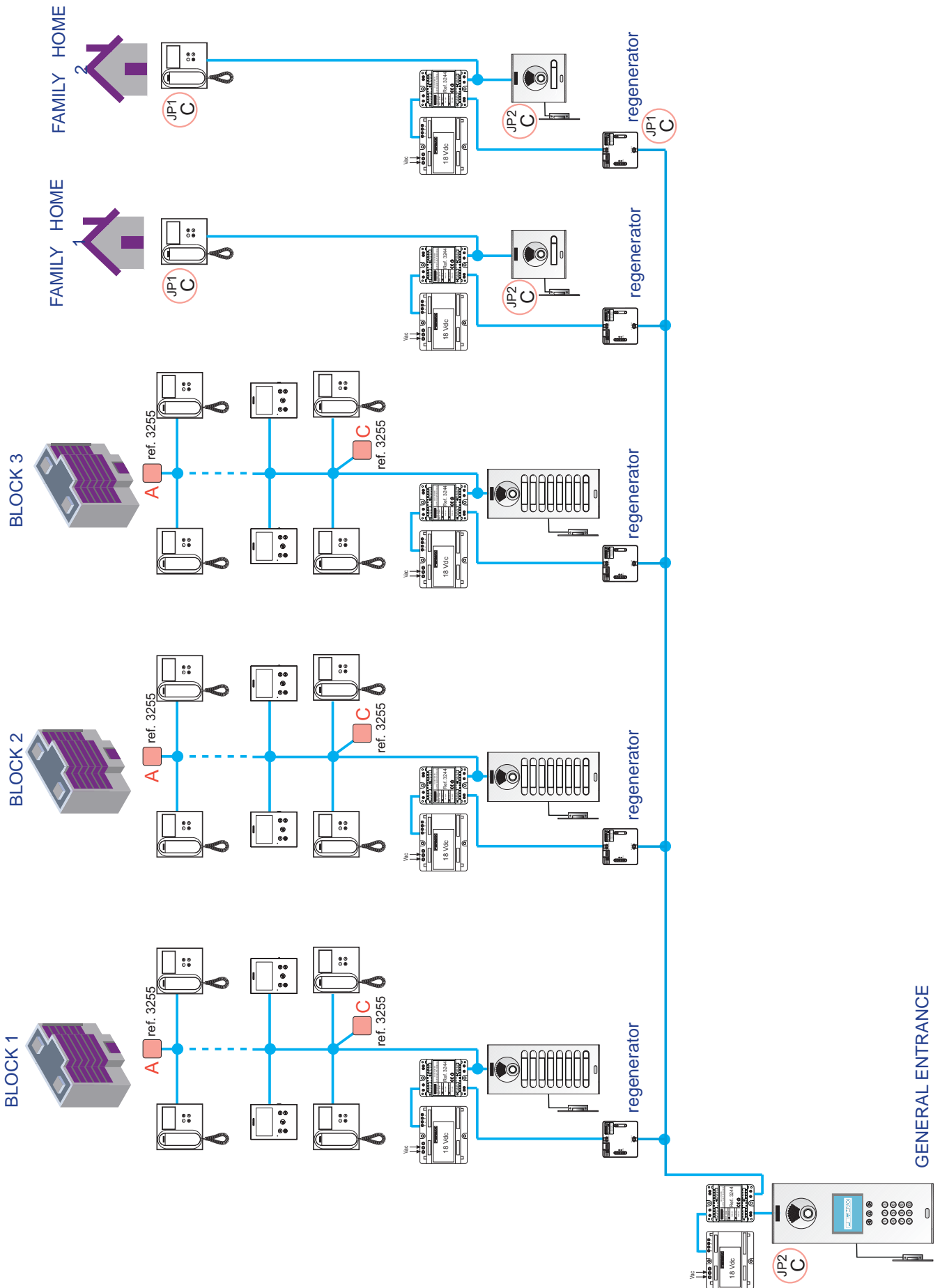

## 6.4 COMPARISON BETWEEN REGENERATORS

The main differences that can be noted between the different regenerators are:

- Size and format.
- Inputs / Outputs.
- Power supply.
- Primary use.

Device	Regenerator 1 Output (Ref. 3256)	Regenerator 2 Outputs (Ref. 3253)	Multi-channel regenerator 1 Output (Ref. 3259)
Specifications			
Size / Format	89 (H) x 86 (V) x 26 (P) mm (DIN 6)	175 (H) x 90 (V) x 60 (P) mm (DIN 10)	89 (H) x 86 (V) x 26 (P) mm (DIN 6)
Inputs	1	1	1
Outputs	1	2	1
Supply	of the BUS (this regenerator does not allow the power supply to pass, which means that the sections from both sides require their own power supply set)	Power supply	of the BUS (this regenerator does not allow the power supply to pass, which means that the sections from both sides require their own power supply set)
Primary use	Regenerate  Isolate	Regenerate  Isolate  Risers	Regenerate  Isolate  Additional channel



## 7. APARTMENT TERMINALS

The DUOX system includes a wide range of apartment terminals, for both door installations (telephones) and video door installations (monitors).

The apartment terminals enable the user to establish audio/video communication with the outdoor panel, to open the door, to call the concierge and so on.

The maximum number of terminals per apartment is three. In order to expand the number of terminals in an apartment it may be necessary to add a power supply set depending on the number of existing apartments and monitors, the topology, the type of cable and so on.

After installation, DUOX apartment terminals require a simple programming process through which the terminal is assigned a "call code/call direction". When a call is made from the outdoor panel to the terminal programmed with this code, the terminal receives the call and is able to establish communication with the outdoor panel. *See sub-section 1.4 Operating principles of the DUOX system.*

### Monitors:

- DUOX monitors should be installed in video installations (with video panels). Video installations can be extended with additional monitors and/or telephones.
- DUOX monitors can be programmed within seconds, directly from the terminal menu, which makes it possible for one single person to programme the installation.
- Monitors with DUOX technology:
  - VEO Monitor.
  - VEO XS Monitor

### Telephones:

- DUOX telephones can be installed in telephone-only installations (audio installations), in mixed installations including telephones and monitors or as an additional device in monitor installations.
- Programming the DUOX telephones is very simple.
- Telephones with DUOX technology:
  - Loft Basic Plus Telephone.
  - Loft Extra Telephone.
  - iLOFT Telephone.



## 7.1 VEO XS MONITOR

### CONTROL BUTTONS / LEDES

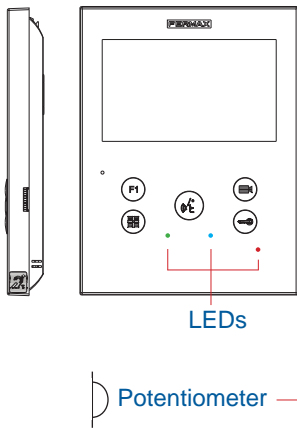

- Digital menu for settings and configuration of internal parameters. (If the monitor has been programmed).
- In conversation, push to open the door.  
In stand-by mode, call to the concierge (if applicable).
- Auxiliary function (check with your installer).  
In standby mode, press and the screen will display the possibility of performing auto switch-on with different outdoor panels. Press Outdoor Panel 0, Outdoor Panel 1, General Outdoor Panel in sequence (depending on the availability of panels).
  - Panel 0 of the monitor block.
  - Panel 1 of the monitor block.
  - Panel 0 of the General Entrance.

*Note: - If a call is received from another panel, when the conversation has been completed, for 15 seconds, **auto switch-on** will happen with that panel.*
- Audio activation and hang-up (hands-free operation).
- Induction loop label. Situated on the side of the monitor.  
(Depending on).
- Ring tone volume setting.  
On standby: At the MINIMUM, call disconnection (Do Not Disturb Mode, flashing red LED).  
Conversation in progress: Upstream audio setting.

**● Red LED:**

Switched on. Monitor is idle.  
Intermittent. Do Not Disturb mode has been activated.

**● Blue LED:**

Intermittent. Monitor not programmed (*idle*).  
Switched on. Conversation in hands-free audio mode.  
On/Intermittent. Conversation in simplex audio mode

**● Green LED:** According to configuration.

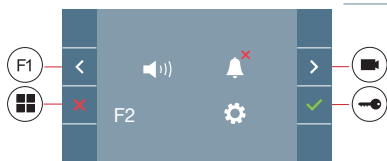

The VEO XS monitor includes an OSD menu which is managed using the monitor pushbuttons to access the functions for using and programming the terminal. The icons displayed on the screen are controlled using the corresponding pushbuttons located on the monitor.

### CONNECTIONS

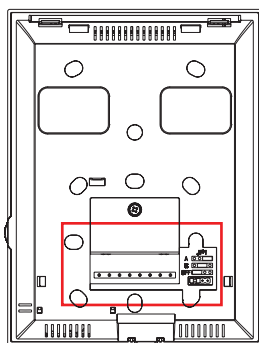

**Monitor Connectors:**

- Bin,Bin: Data, audio and video input.
- Bout,Bout: Data, audio and video output (*for cascade connection*).
- T, -: Apartment door call button (*P1*).
- A+, -: Option of connection with the following devices:
  - Call extender ref. 2040.
  - Light and buzzer commander ref. 2438.
- F1: Additional function.

**JP1: Integrated line adapter bridge**

- Right: Adaptation type A.
- Centre: Adaptation type C.
- Left: Without line adaptation: OFF, (by default).

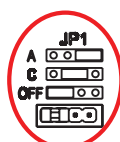
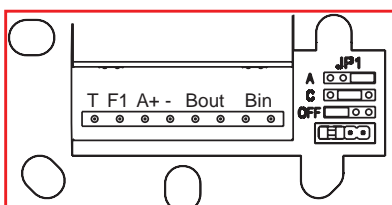

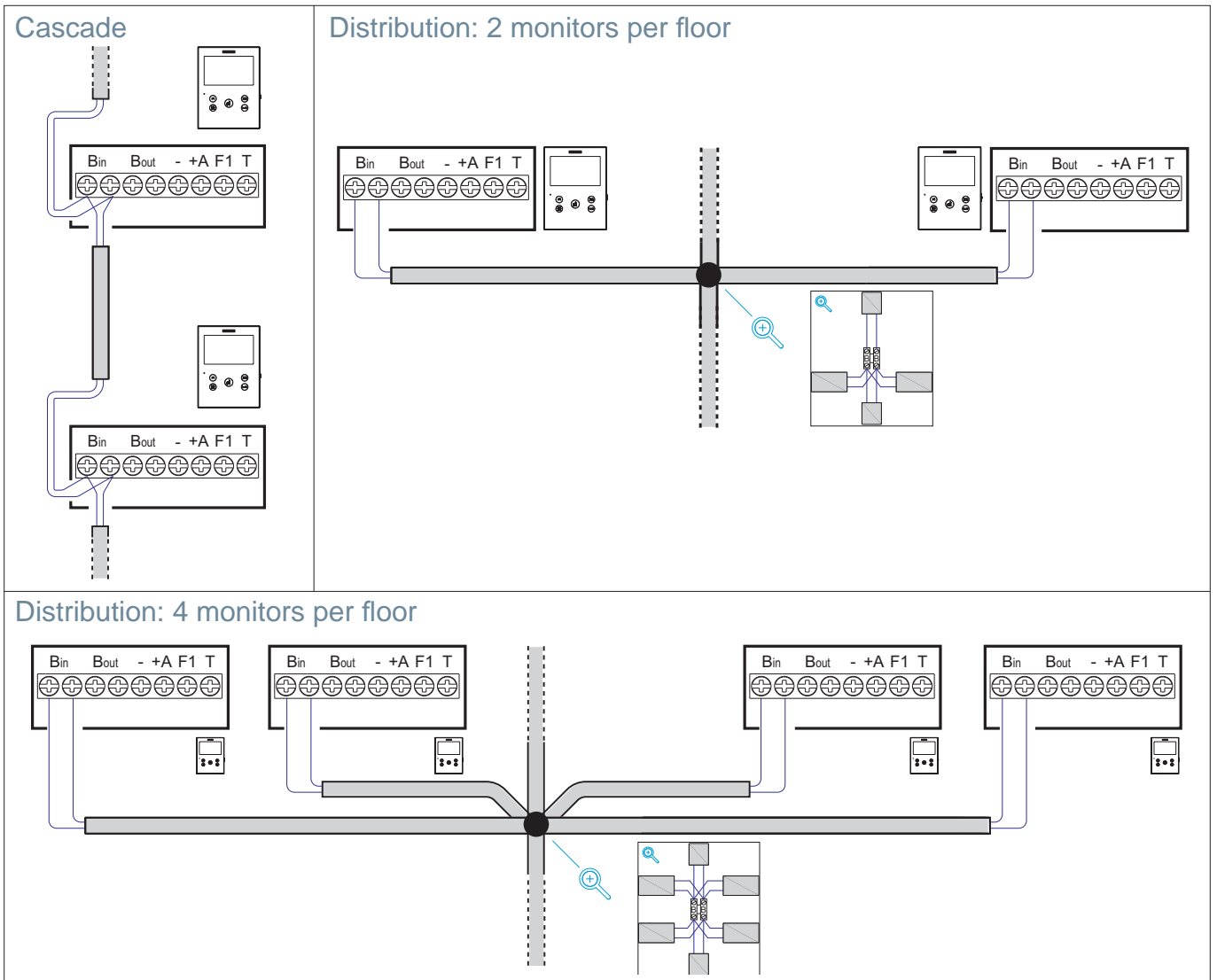

### MONITOR PROGRAMMING

Notes:

- Before programming the monitor, the outdoor panel should be set as the master outdoor panel.
- **Configuration as master outdoor panel.** Press button SW1 3 times in quick succession. Once 2 seconds have elapsed, a confirmation tone will sound and the master outdoor panel will be activated. Once the programming of the monitors is complete, it is advisable to deactivate the MASTER outdoor panel by pressing button SW1 3 consecutive times.

#### 1. INSTALLATION

Monitor supplied with power for the first time.

A blue LED, blinking slowly, indicates that the monitor is not programmed.

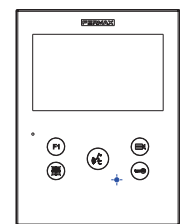

#### 2. ENTERING THE PROGRAMMING MENU

Press the button to access the “programming menu”..

#### PROGRAMMING FROM AN OUTDOOR PANEL

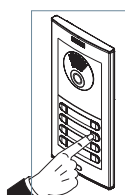

Select the icon and confirm with , (a “beep” will be heard in the monitor).

Press the corresponding pushbutton from the outdoor panel (call code for that monitor). A different ring tone will sound, confirming the programming of the monitor. After a few seconds, the monitor will return to standby mode.

**PROGRAMMING FROM THE MONITOR** (only one person is required to complete the programming process)



Select the **>** icon and confirm with .

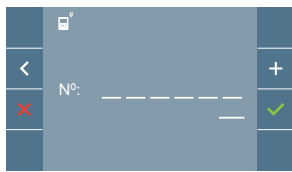

Each time that **+** is pressed, the number increases (starting from 1) and the arrow **<** is used for scrolling.



The white cursor indicates the entry position of the digit. Confirm with to complete the process.

**3. MONITOR SETTINGS**

**VIDEO SETTINGS**

When there is an image on the monitor after pressing the button, (or if a call is received without establishing audio communication), press the key to display the video settings.

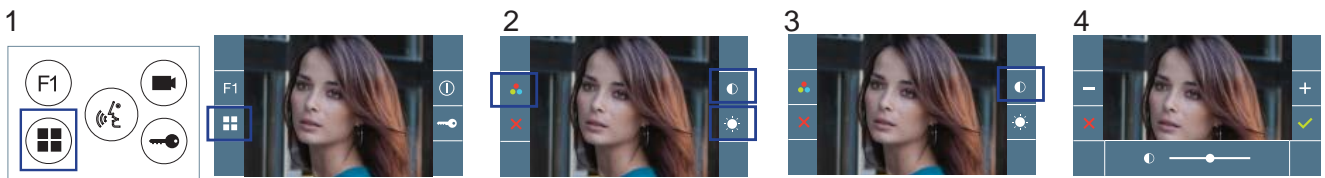

Select the settings option and increase and decrease using **+** and **-**.

**AUDIO SETTINGS**

While the audio channel is open, press the button and the menu for this setting will appear on the screen.

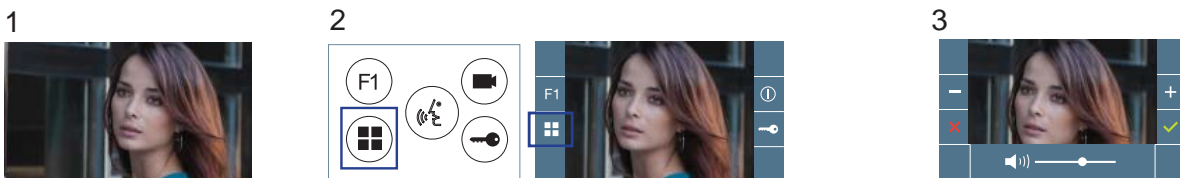

Increase or decrease using **+** and **-**, until obtaining the required regulation.

*Note: Maximum conversation time: 90 seconds.*

**USER SETTINGS**

Access User Parameters.

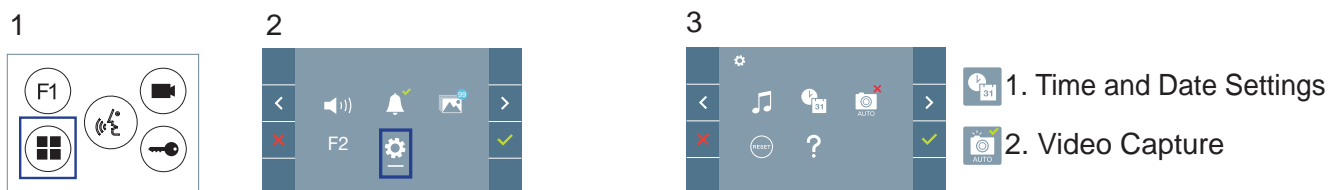

Select the **>** icon and confirm with .

- 1. Time and Date Settings
- 2. Video Capture

### 1. TIME AND DATE SETTINGS

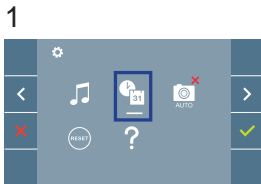

Select the icon and confirm with .

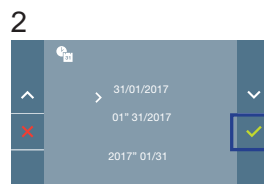

Use to select the date format. Once this has been selected, confirm using .

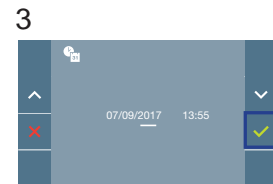

Select the time and date with and confirm . To navigate through the settings .

Non-programmed date: 01/01/2017 (by default). The icon will appear, indicating that the date is not correct (default date). If the power supply is lost, the default date will be restored.

*Note: If an image is captured without the date having being programmed, the icon will be displayed.*

Icons notifying of a non-programmed date::

#### User Menu screen

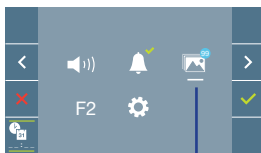
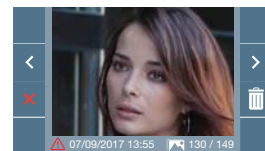

Image display

#### Communication screen



#### Image Display screen



### 2. ACTIVATION/DEACTIVATION OF VIDEO CAPTURE

The monitor can take an automatic picture within 5 seconds of receiving a call from an outdoor panel. According to the European Union legislation about data protection ((EU) 2016/679), the capture of images may be restricted. This feature is deactivated by default in all monitors, although can be activated at your own responsibility.

Furthermore, the legislation may force to place a sign next to door stations, indicating that monitors can capture images. You can download it at <https://www.fermax.com/intl/en/corporate/utilities.html>.

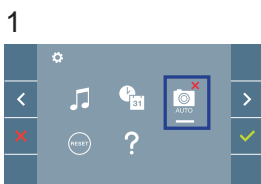

Select the icon and confirm with .

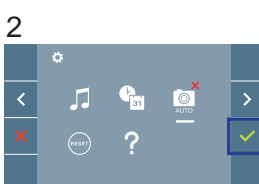

Push to activate/deactivate the function.

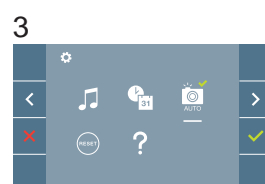

### TECHNICAL SPECIFICATIONS

Power supply	18 Vdc
Standby consumption	38 mA
Maximum consumption	370 mA
Maximum consumption with induction loop	850 mA
OSD screen	TFT 3,4"
6-digit address	000001...999999
Operating temperature	[-5° , +40°C] / [23° , 104°F]
Dimensions	165 x 125 x 21mm - 6.5" x 4.9" x 0.8" - (Height x Width x Depth)
Conversation modes	
hands-free	by default
simplex	push to talk: push button  to talk, release to listen

## 7.2 VEO MONITOR

### CONTROL BUTTONS / LEDS

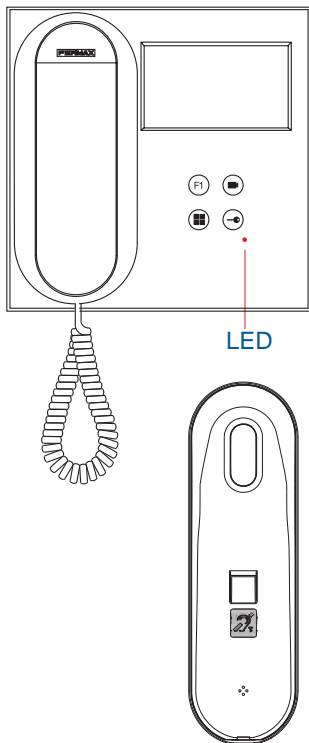

- Digital menu for settings and configuration of internal parameters. (If the monitor has been programmed).
- In conversation, push to open the door.  
In stand-by mode, call to the concierge (if applicable).
- Auxiliary function (check with your installer).
- In standby mode, press and the screen will display the possibility of performing auto switch-on with different outdoor panels. Press Outdoor Panel **0**, Outdoor Panel **1**, **General Outdoor Panel** in sequence (depending on the availability of panels).
  - Panel 0 of the monitor block.
  - Panel 1 of the monitor block.
  - Panel 0 of the General Entrance.

*Note: - If a call is received from another panel, when the conversation has been completed, for 15 seconds, **auto switch-on** will happen with that panel.*
- Induction loop label. Located at the internal part of the receiver.  
(Depending on the model).

**● Red LED:**

- Switched on. Monitor is idle.
- Intermittent fast blinking. Monitor not programmed.
- Intermittent slow blinking. Do Not Disturb mode has been activated.

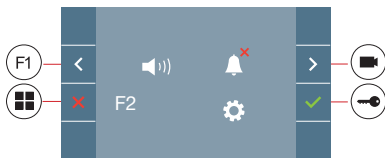

The VEO monitor includes an OSD menu which is managed using the monitor pushbuttons to access the functions for using and programming the terminal. The icons displayed on the screen are controlled using the corresponding pushbuttons located on the monitor.

### CONNECTIONS

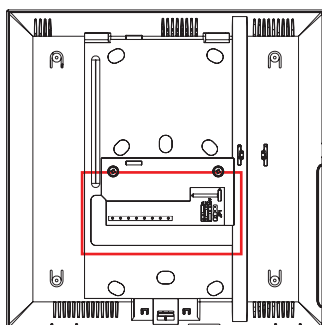

**Monitor Connectors:**

- Bin, Bin: Data, audio and video input.
- Bout, Bout: Data, audio and video input (*cascade connection*).
- T, -: Apartment door call button (*P1*).

A+, -: Option of connection with the following devices:

- Call extender ref. 2040.
- Light and buzzer commander ref. 2438.

F1: Additional function.

**JP1: Integrated line adapter bridge**

- Top: Adaptation type A.
- Centre: Adaptation type C.
- Bottom: Without line adaptation: OFF, (by default).

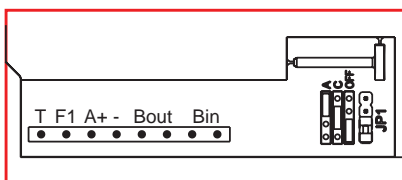

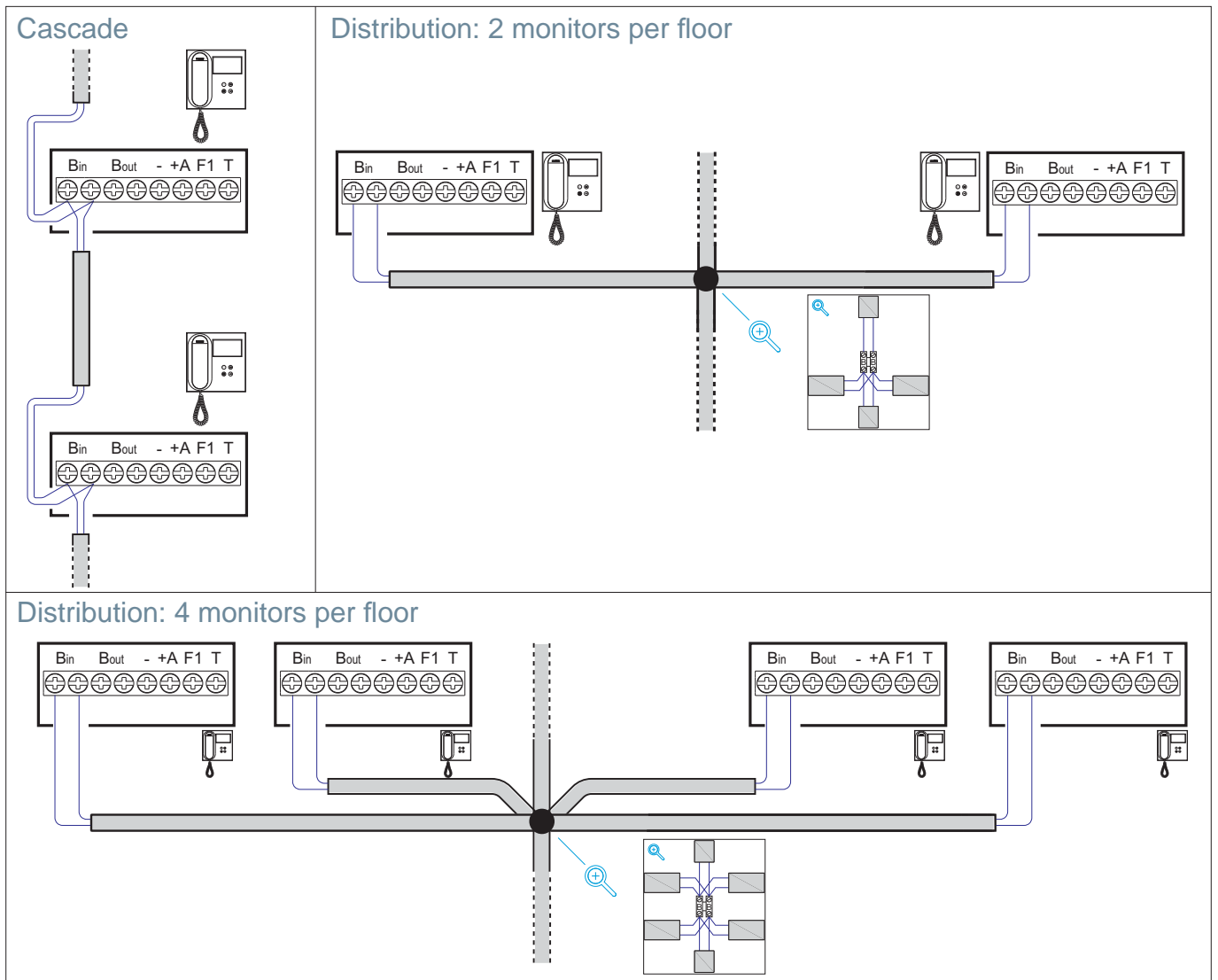

## MONITOR PROGRAMMING

Notes:

- Before programming the monitor, the outdoor panel should be set as the master outdoor panel.
- **Configuration as master outdoor panel.** Press the SW1 button 3 times in quick succession. Once 2 seconds have elapsed, a confirmation tone will sound and the master outdoor panel will be activated. Once the programming of the monitors is complete, it is advisable to deactivate the MASTER outdoor panel by pressing button SW1 3 consecutive times.

### 1. INSTALLATION

Monitor supplied with power for the first time.

A red LED, blinking slowly, indicates that the monitor is not programmed.

A fixed LED light indicates that the monitor has been programmed.

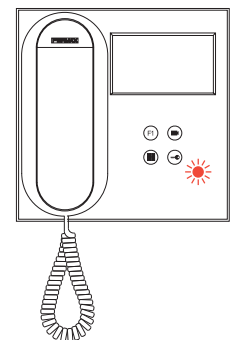

### 2. ENTERING THE PROGRAMMING MENU

Press the  button to access the “programming menu”.

#### PROGRAMMING FROM AN OUTDOOR PANEL

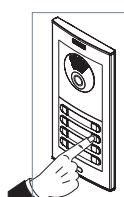
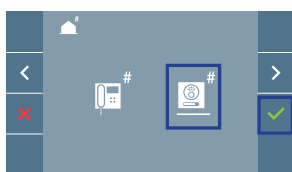

Select the  icon and confirm with  , (a “beep” will be heard in the monitor).

Press the corresponding pushbutton from the outdoor panel (call code for that monitor). A different ring tone will sound, confirming the programming of the monitor. After a few seconds, the monitor will return to standby mode.



**PROGRAMMING FROM THE MONITOR** (only one person is required to complete the programming process)

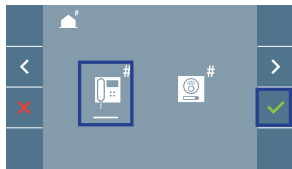

Select the **>** icon and confirm with .

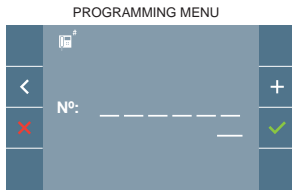

Each time that **+** is pressed, the number increases (starting from 1) and the arrow **<** is used for scrolling.



The white cursor indicates the entry position of the digit. Confirm with to complete the process.

**3. MONITOR SETTINGS**

**VIDEO SETTINGS**

When there is an image on the monitor after pressing the button, (or if a call is received without picking up the receiver), press the key to display the video settings.

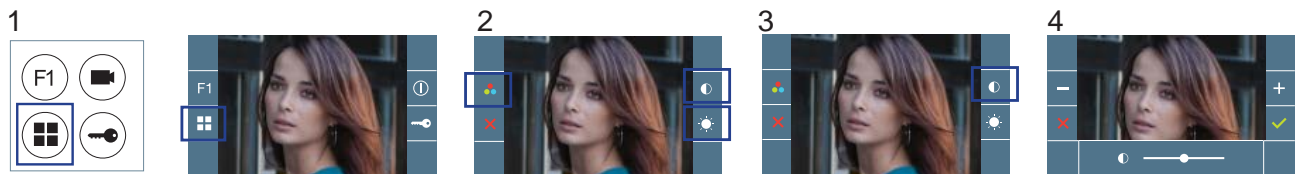

Select the settings option and increase and decrease using **+** and **-**.

**AUDIO SETTINGS**

While the audio channel is open, press the button and the menu for this setting will appear on the screen.

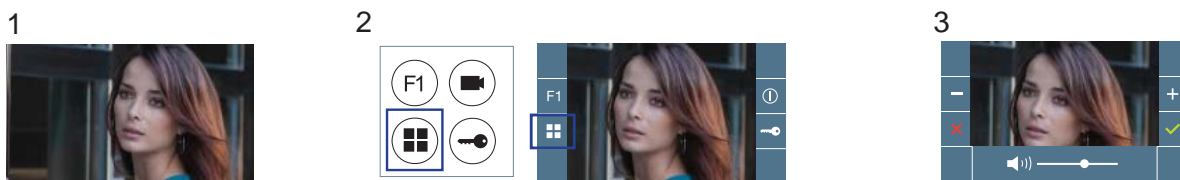

Increase or decrease using **+** and **-**, until obtaining the required regulation.

*Note: Maximum conversation time: 90 seconds.*

**USER SETTINGS**

Access User Parameters.

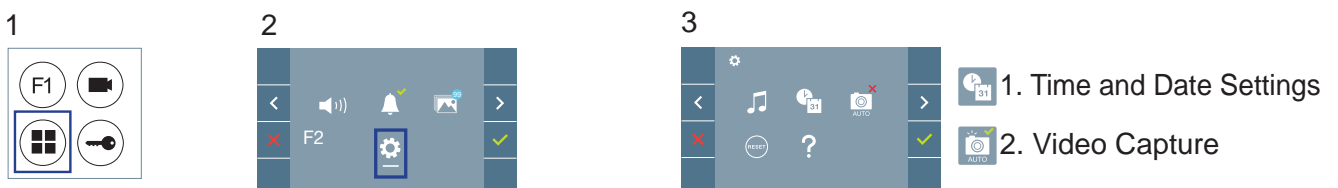



Select the **>** icon and confirm with .

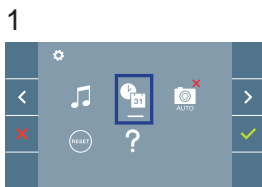

- 1. Time and Date Settings
- 2. Video Capture

### 1. DATE AND TIME SETTINGS



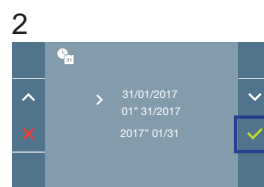



1  
Select the **>** icon  and confirm with .

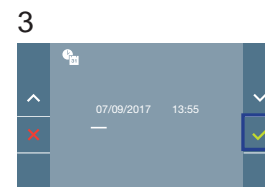

2  
Use   to select the date format. Once this has been selected, confirm using .



3  
Select the time and date with   and confirm . To navigate through the settings .

Non-programmed date: 01/01/2017 (by default). The  icon will appear, indicating that the date is not correct (default date). If the power supply is lost, the default date will be restored.

Note: If an image is captured without the date having being programmed, the  icon will be displayed.

Icons notifying of a non-programmed date::

#### User Menu screen

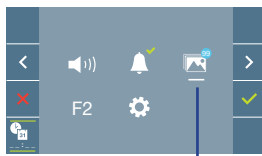
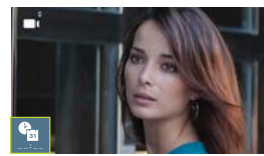

Image display

#### Communication screen



#### Image Display screen





### 2. ACTIVATION/DEACTIVATION OF VIDEO CAPTURE

The monitor can take an automatic picture within 5 seconds of receiving a call from an outdoor panel. According to the European Union legislation about data protection ((EU) 2016/679), the capture of images may be restricted. This feature is deactivated by default in all monitors, although can be activated at your own responsibility.

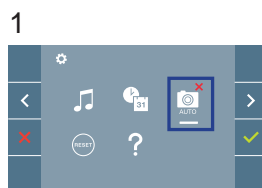
Furthermore, the legislation may force to place a sign next to door stations, indicating that monitors can capture images. You can download it at <https://www.fermax.com/intl/en/corporate/utilities.html>.



1  
Select the **>** icon  and confirm with .

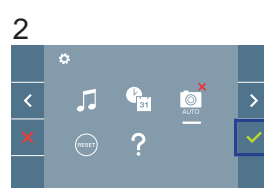

2  
Push  to activate/deactivate the function.

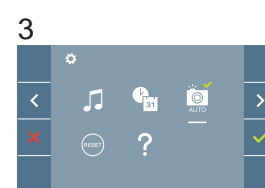

### TECHNICAL SPECIFICATIONS

Power supply	18 Vdc
Standby consumption	35 mA
Maximum consumption	230 mA
OSD screen	TFT 4,3"
6-digit address	000001...999999
Operating temperature	[-5° , +40°C] / [23° , 104°F]
Dimensions	200 x 200 x 46mm - 8" x 8" x 1.8" - (Height x Width x Depth)



### 7.3 LOFT BASIC PLUS TELEPHONE

#### CONTROL BUTTONS

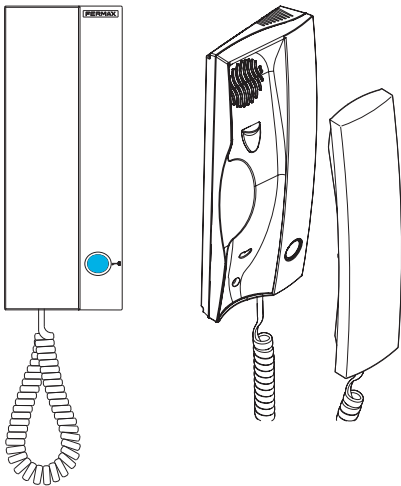

Lock release button / Call to the concierge:

- While in conversation with the outdoor panel, pushing this button will activate the lock release.
- With the telephone hanging up (in standby mode), pressing this button will make a call to the concierge (if applicable).

Auto switch-on when picking up the telephone. (Must be programmed).

This feature is possible with the outdoor panel of the same block, if the outdoor panel is in standby mode and programmed as "0" and if there is a conversation channel available.

*Note:* - If a call is received from another panel, when the conversation has been completed, for 15 seconds, **auto switch-on** will happen with that panel.

#### CONNECTIONS

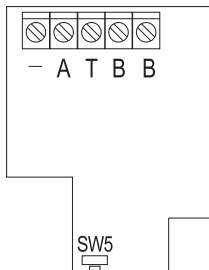

#### Telephone Connectors:

B,B: Power supply to telephones, data and audio.

T, -: Apartment door call button (P1).

A+, -: Option of connection with the following devices:

- Call extender ref. 2040.
- Light and buzzer commander ref. 2438.

SW5: Button to enter programming.

#### Cascade

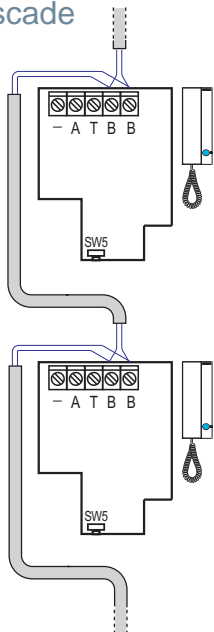

#### Distribution: 2 telephones per floor

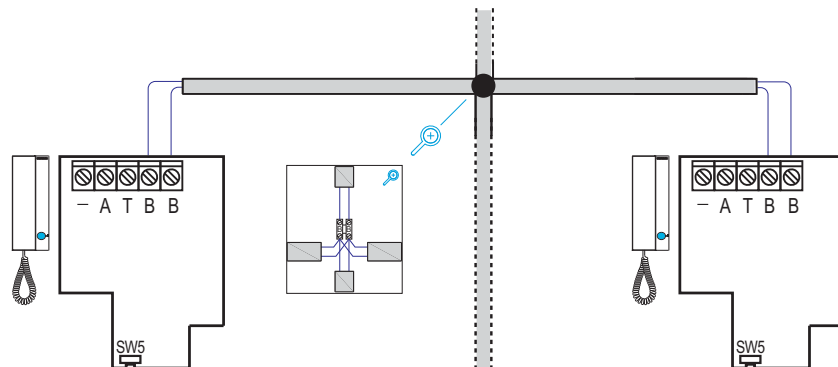

#### Distribution: 4 telephones per floor

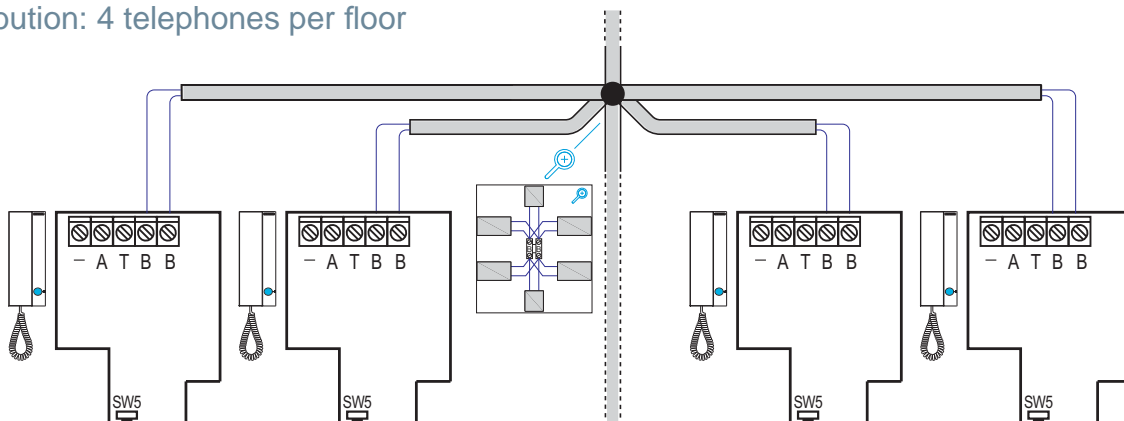

## TELEPHONE PROGRAMMING

Notes:

- Before programming the telephone, the outdoor panel should be set as the master outdoor panel.
- **Configuration as master outdoor panel.** Press button SW1 3 times in quick succession. Once 2 seconds have elapsed, a confirmation tone will sound and the master outdoor panel will be activated. Once the programming of the monitors is complete, it is advisable to deactivate the MASTER outdoor panel by pressing button SW1 3 consecutive times.
- If there is a guard unit this should be in night mode.

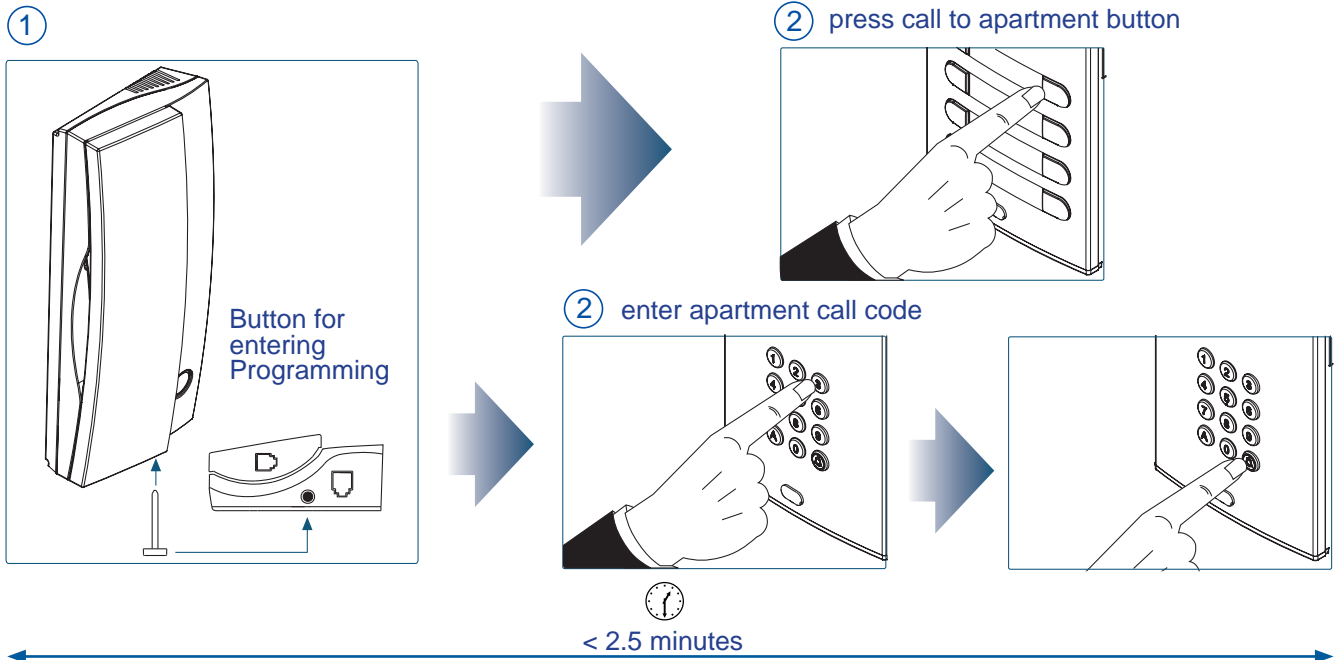

1. With the telephone connected and hung up, press the programming button until a “beep” sounds. On releasing the programming button, the “enter programming mode” will sound (long beep).

*As an additional option, the telephone handset can be picked up to establish communication with the outdoor panel and inform the operator of which apartment it is found in. The door release is also permitted.*

2. Press the call button for the apartment or enter the corresponding code. The programming confirmation will result (if the telephone is hung up).

Check that the telephone has been programmed by making a call.

*Note: The telephone will not function if it has not been programmed.*

## USER SETTINGS

### CALL RING TONE SELECTION (MELODIES)

The telephone can be used to select a separate melody for the calls received from outdoor panels and for the calls made from guard units.

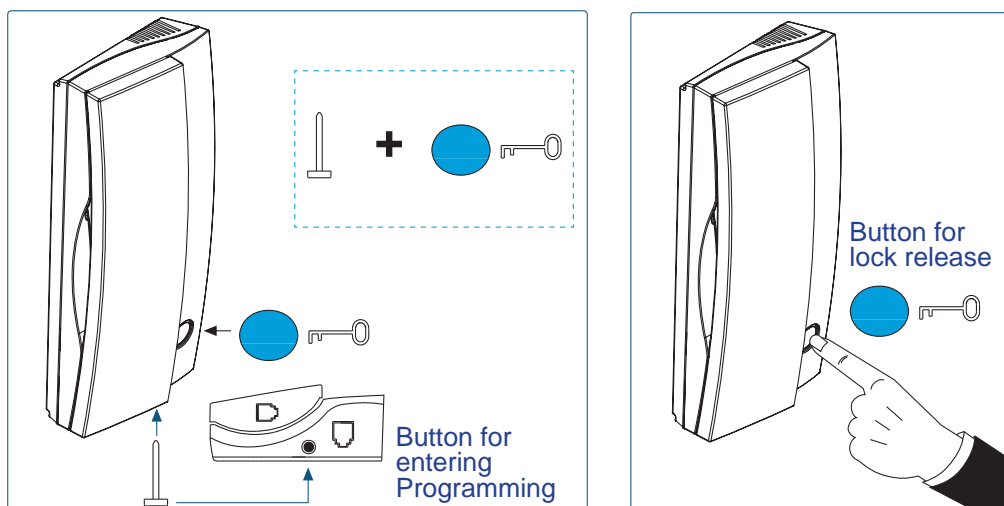

- 1. Selection of call ring tone for outdoor panel:** With the telephone hung up and on standby mode, press the programming button of the telephone (a “beep” will sound) and without releasing this button, press the lock release button. The current melody will be heard. Release the programming button. Each time the lock release button is pressed again, the next melody will sound.
- 2. Selection of call ring tone for guard unit:** While in the outdoor panel call ring tone selection menu, pressing and holding the lock release button for 5 seconds will play the current melody for calls from the guard unit. Each time the lock release button is pressed again, the next melody will sound.

*Note: The call ring tone selection process is exited after 10 seconds of inactivity (with the last melody reproduced being stored in the memory). This exit is confirmed by: Single beep: from the outdoor panel and double beep: from the guard unit.*

## TECHNICAL SPECIFICATIONS

Power supply	18 Vdc
Standby consumption	12 mA
Maximum consumption	200 mA
Maximum conversation time	90 seconds
6-digit address	000001...999999
Operating temperature	[-5° , +40°C] / [23° , 104°F]
Choice of call melodies	
Number of conversation channels (audio-only installation):	2 per bus



## 7.4 LOFT EXTRA TELEPHONE

### CONTROL BUTTONS / LEDS

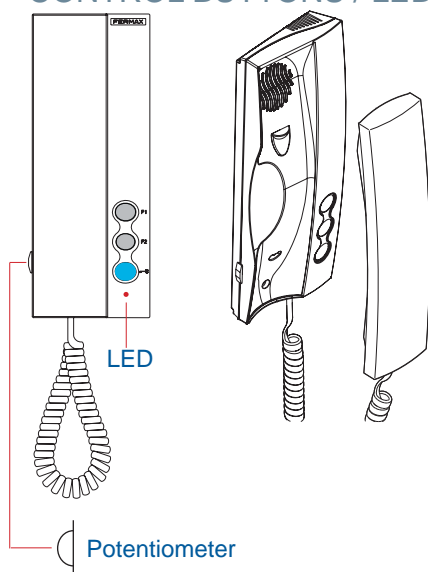

-  Lock release button / Call to the concierge:
  - While in conversation with the outdoor panel, pushing this button will activate the lock release.
  - With the telephone hanging up (in standby mode), pushing this button will make a call to the concierge (if applicable).

Auto switch-on when picking up the telephone. (Must be programmed).

This feature is possible with the outdoor panel of the same block, if the outdoor panel is in standby mode and programmed as “0” and if there is a conversation channel available.

*Note: If a call is received from another panel, when the conversation has been completed, for 15 seconds, **auto switch-on** will happen with that panel.*

-  F1 Auxiliary function (check with your installer).

-  F2

-  Ring tone volume setting.  
On standby: At the MINIMUM, call disconnection (Do Not Disturb Mode, red LED lit).  
Conversation in progress: Upstream audio setting.

#### ● Red LED:

- Switched on. Do Not Disturb mode has been activated.
- Intermittent. Non-programmed telephone (*standby*).
- Shut down. Programmed telephone (*standby*), or without power source.

### CONNECTIONS

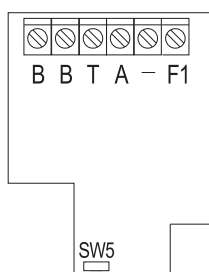

#### Telephone Connectors:

B,B: Power supply to telephones, data and audio.

T, -: Apartment door call button (*P1*).

A+, -: Option of connection with the following devices:

- Call extender ref. 2040.
- Light and buzzer commander ref. 2438.

F1: Button for additional functions. Provides a negative upon activation.

SW5: Button to enter programming.

Cascade

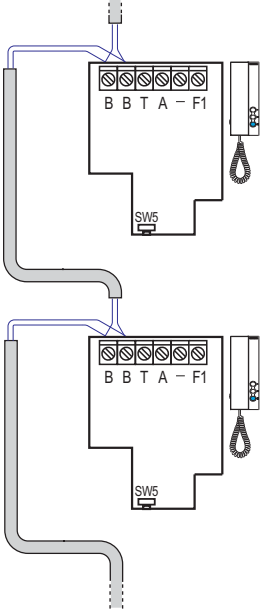

Distribution. 2 telephones per floor

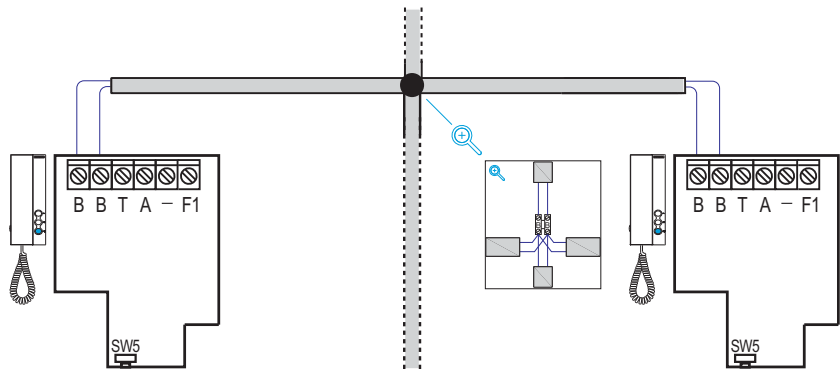

Distribution. 4 telephones per floor

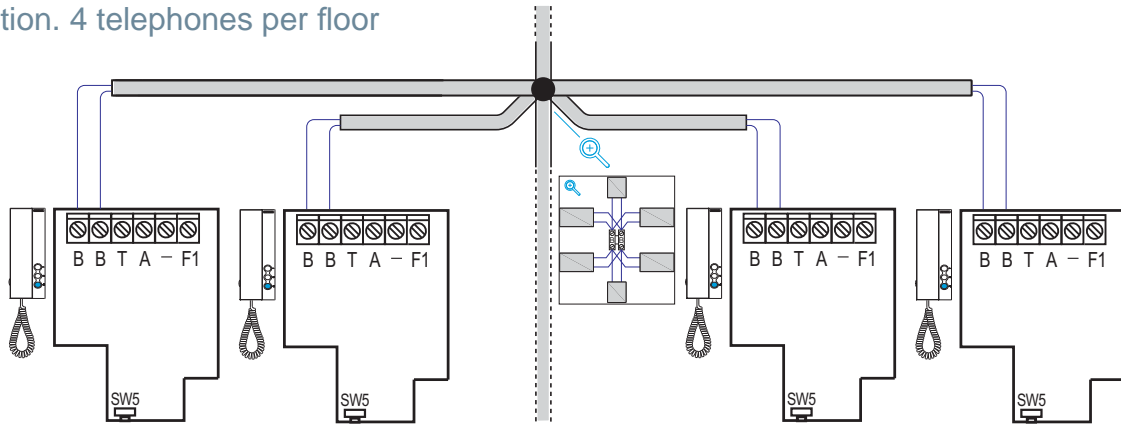

TELEPHONE PROGRAMMING

Notes:

- Before programming the telephone, the outdoor panel should be set as the master outdoor panel.
- **Configuration as master outdoor panel.** Press button SW1 3 times in quick succession. Once 2 seconds have elapsed, a confirmation tone will sound and the master outdoor panel will be activated. Once the programming of the monitors is complete, it is advisable to deactivate the MASTER outdoor panel by pressing button SW1 3 consecutive times.
- If there is a guard unit this should be in night mode.

①

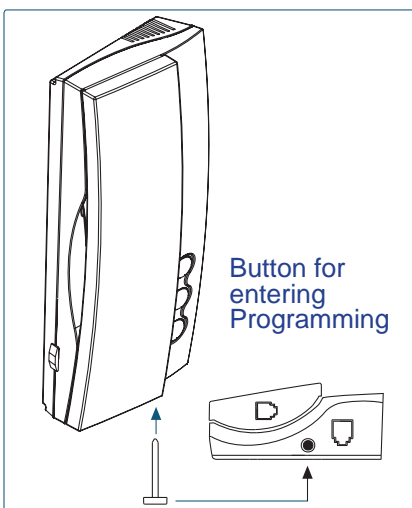

② press call to apartment button

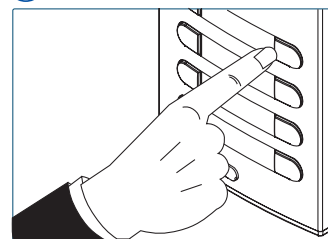

② enter apartment call code

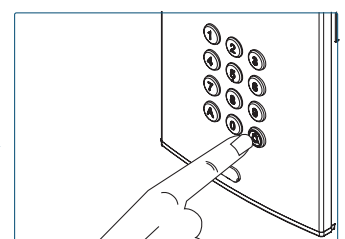
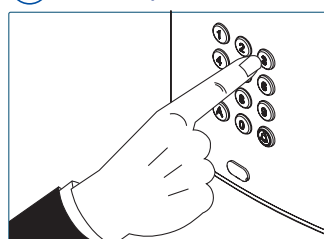

< 2.5 minutes

1. With the telephone connected and hung up, press the programming button until a “beep” sounds. On releasing the programming button, the “enter programming mode” will sound (long beep).  
*As an additional option, the telephone handset can be picked up to establish communication with the outdoor panel and inform the operator of which apartment it is found in. The door release is also permitted.*
2. Press the call button for the apartment or enter the corresponding code. The programming confirmation will result (if the telephone is hung up).

Check that the telephone has been programmed by making a call.

*Note: The telephone will not function if it has not been programmed.*

## USER SETTINGS

### CALL RING TONE SELECTION (MELODIES)

The telephone can be used to select a separate melody for the calls received from outdoor panels and for the calls made from guard units.

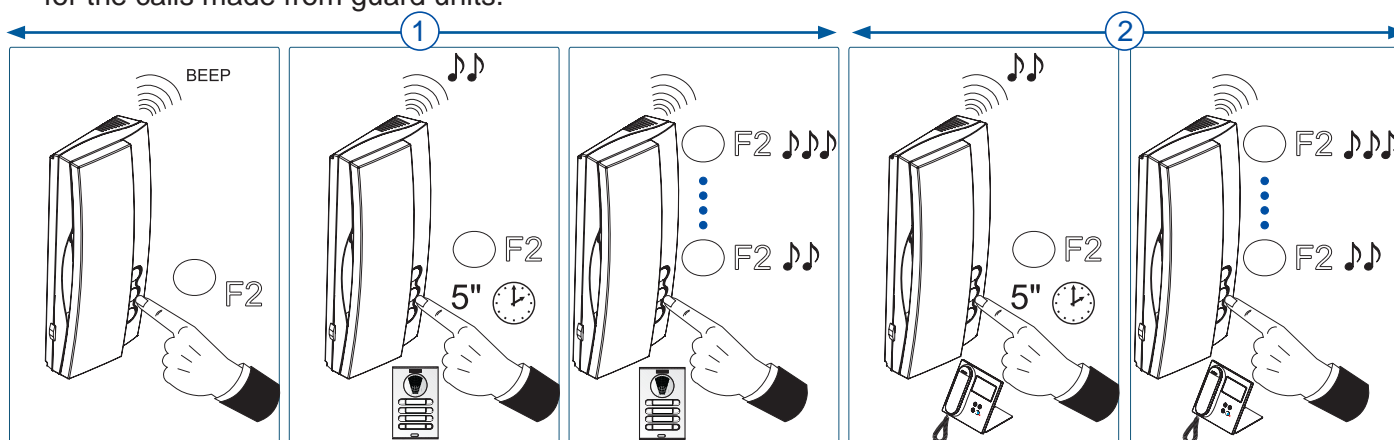

1. **Selection of call ring tone for outdoor panel:** With the telephone hung up and on standby mode, press button F2 (a “beep” will sound). After keeping the button pressed down for 5 seconds, the current melody will be heard. With each new short pulse on F2, the next melody will sound. After reaching melody 5, the cycle begins again with melody 1. The last melody to play will be the one that is selected.
2. **Selection of call ring tone for guard unit:** While in the outdoor panel melody selection menu, holding down F2 for 5 seconds will play the current call melody for calls from the guard unit. With each new short pulse on F2, the next melody will sound. After reaching melody 5, the cycle begins again with melody 1.

Notes:

- The call ring tone selection process is exited after 10 seconds of inactivity (with the last melody reproduced being stored in the memory). This exit is confirmed by: Single “beep”: from the outdoor panel and double “beep”: from the guard unit.
- While in the guard unit melody menu, pressing down F2 for 5 seconds will leave the guard unit melody menu and return to standby mode, storing the selected melody. This exit is confirmed by a double “beep”.

## TECHNICAL SPECIFICATIONS

Power supply	18 Vdc
Standby consumption	<15 mA
Maximum consumption	200 mA
Maximum conversation time	90 seconds
6-digit address	000001...999999
Operating temperature	[-5° , +40°C] / [23° , 104°F]
Choice of call melodies	
Number of conversation channels (audio-only installation):	2 per bus



## 7.5 iLOFT TELEPHONE

### CONTROL BUTTONS / LEDS

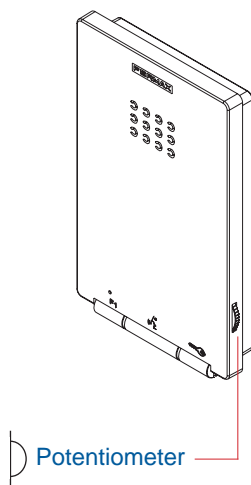
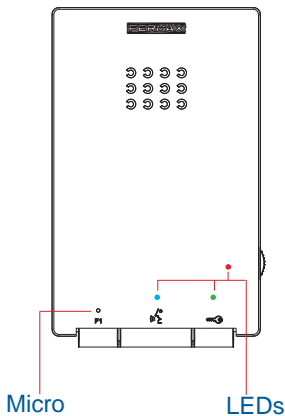

Lock release button / Call to the concierge:

- While in conversation with the outdoor panel (audio activated), pushing this button will activate the lock release.
- On receiving the call (non-active audio). If audio communication is not established, there are 30 seconds in which to complete the release process.
- With the telephone hanging up (in standby mode), pressing this button will make a call to the concierge (if applicable).



Audio Activation, Hang-Up and Auto Switch-On Buttons:

- When receiving a call, there is a 30-second interval in which to answer. The red LED light shuts down during this time, indicating a pending call.
- Audio activation: When you receive a call press this button to speak with the visitor. The audio channel is opened and operation is in hands-free mode (by default). The blue LED will remain lit indicating the conversation with the outdoor panel.
- Hung up: Press to end the conversation, or the conversation will end after 90 seconds.
- Auto switch-on: In standby mode, press and release this button, (the blue LED will light up).

This feature is possible with the outdoor panel of the same block, if the outdoor panel is in standby mode and programmed as "0" and if there is a conversation channel available.

*Note: If a call is received from another panel, when the conversation has been completed, for 15 seconds, **auto switch-on** will happen with that panel.*

### F1

Auxiliary function (check with your installer).



Ring tone volume setting.

On standby: At the MINIMUM, call disconnection (Do Not Disturb Mode, red LED blinking).

Conversation in progress: Upstream audio setting.

#### ● Red LED:

Switched on. Programmed telephone (*standby*).

Intermittent fast blinking. Non-programmed telephone (*standby*).

Intermittent slow blinking. Indicates that the Do Not Disturb feature is enabled.

Switched off. Telephone indicating a pending call, or a lack of any power supply.

#### ● Blue LED:

Switched on. Conversation in hands-free audio mode.

On/Intermittent. Conversation in simplex audio mode

#### ● Green LED: According to configuration.

### CONNECTIONS

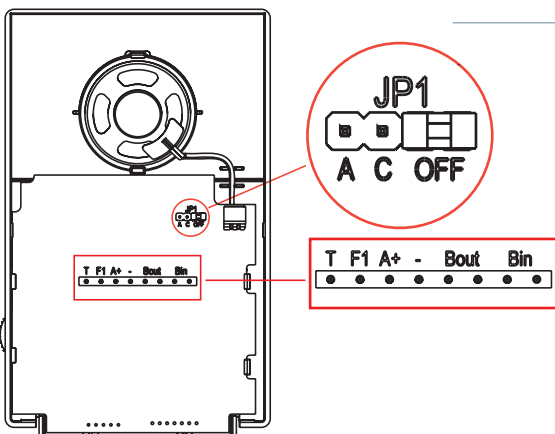

#### Telephone Connectors:

B,B: Power supply to telephones, data and audio.

T, -: Apartment door call button (P1).

A+, -: Option of connection with the following devices:

- Call extender ref. 2040.
- Light and buzzer commander ref. 2438.

F1: Additional function. Provides a negative upon activation.

#### JP1: Integrated line adapter bridge

- Right: Without line adaptation: OFF, (by default).
- Centre: Adaptation type C.
- Left: Adaptation type A.



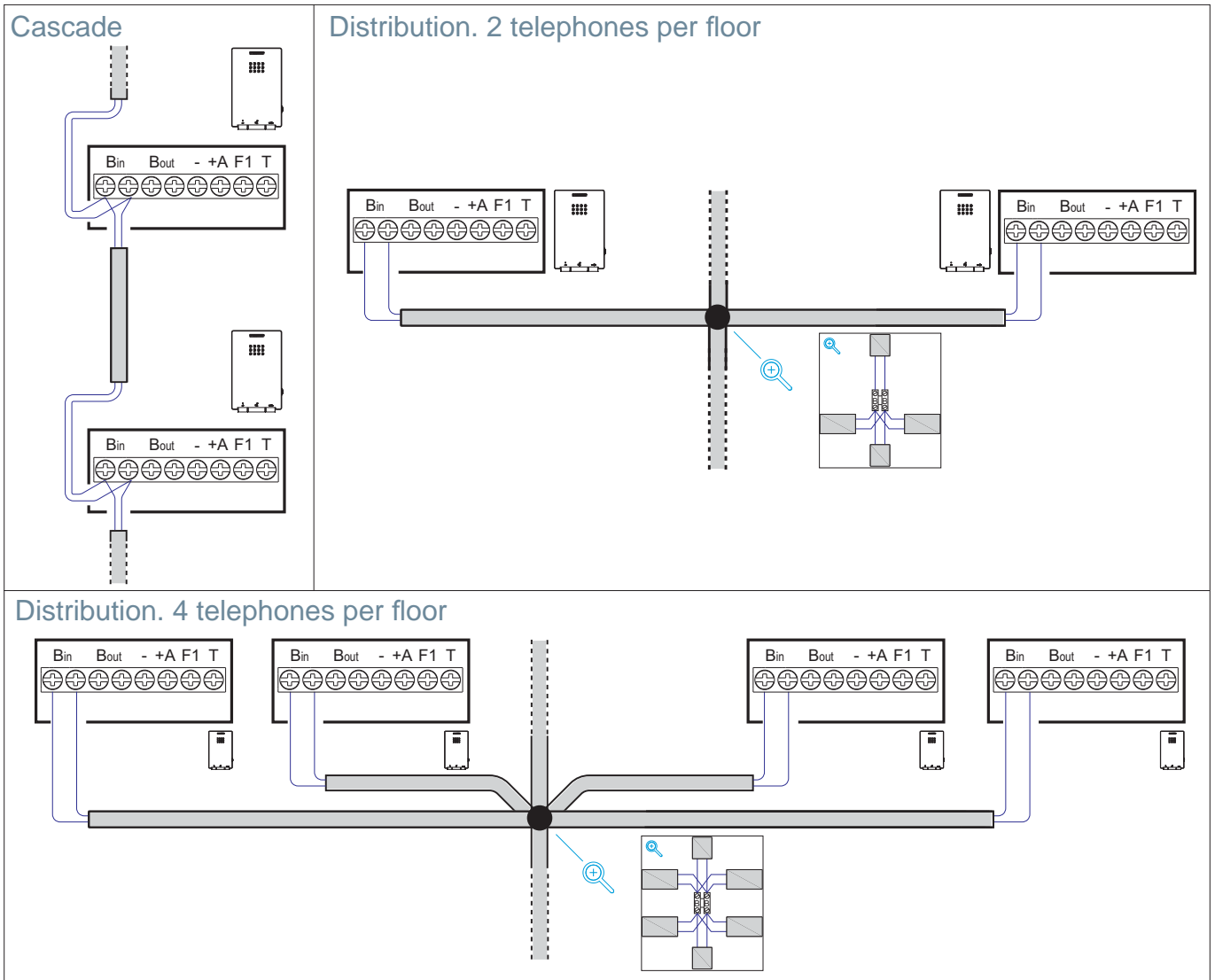

## TELEPHONE PROGRAMMING

**Notes:**

- Before programming the telephone, the outdoor panel should be set as the master outdoor panel.
- **Configuration as master outdoor panel.** Press button SW1 3 times in quick succession. Once 2 seconds have elapsed, a confirmation tone will sound and the master outdoor panel will be activated. Once the programming of the monitors is complete, it is advisable to deactivate the MASTER outdoor panel by pressing button SW1 3 consecutive times.
- If there is a guard unit this should be in night mode.

With the telephone connected and in standby mode:

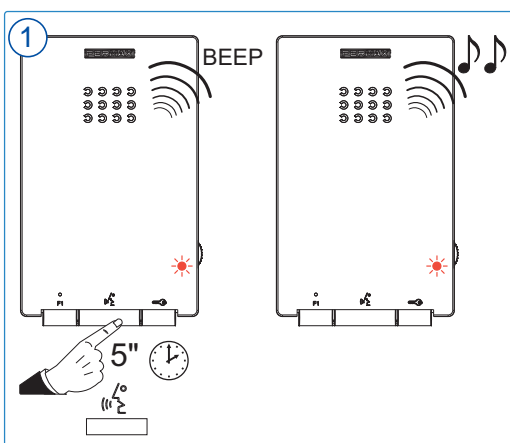

1. Start from the **“Melody selection from outdoor panel”** configuration menu.

Press the  $\llcorner$  button for 5” until a “beep” sounds. Release the button and the current outdoor panel melody will sound. (Non-programmed telephone, red LED blinking rapidly). In this status:

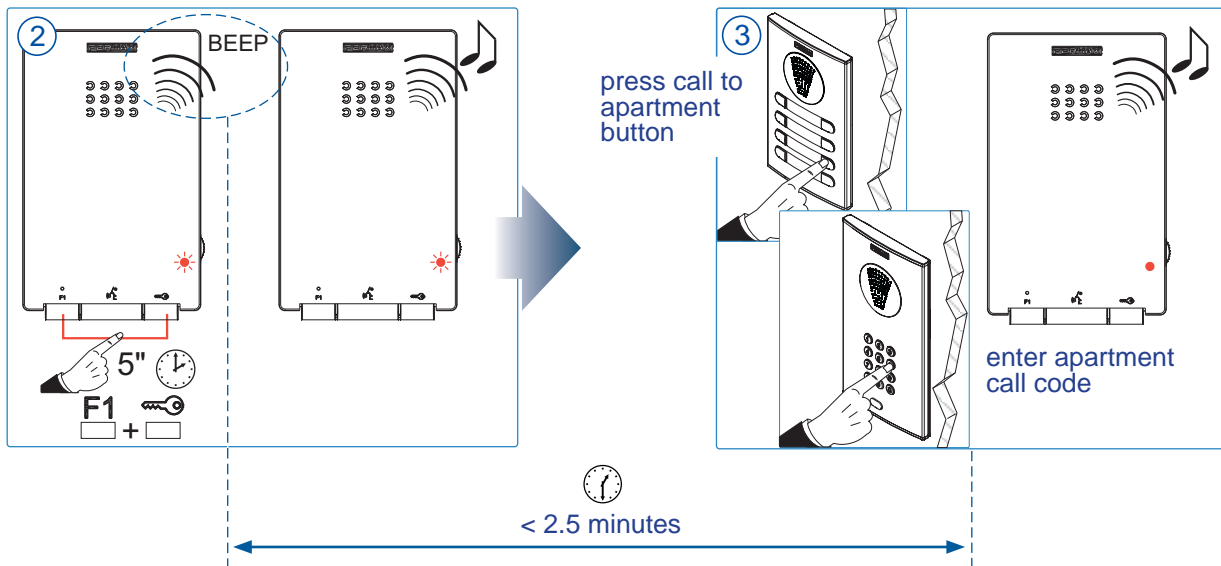

2. Press the F1 button and the button simultaneously for 5" until a "BEEP" confirmation sounds (a beep confirming entering programming mode). Release.

3. Press the call code/button from the outdoor panel to the apartment. A confirmation tone will sound in the telephone. The telephone is programmed (fixed red LED).

*Note: The period between the sounding of the "beep" confirming entry into the telephone programming mode and the call being made from the outdoor panel to program the telephone address must be less than 2 and a half minutes.*

## USER SETTINGS

### CALL RING TONE SELECTION (MELODIES)

The telephone can be used to select a separate melody for the calls received from outdoor panels and for the calls made from guard units.

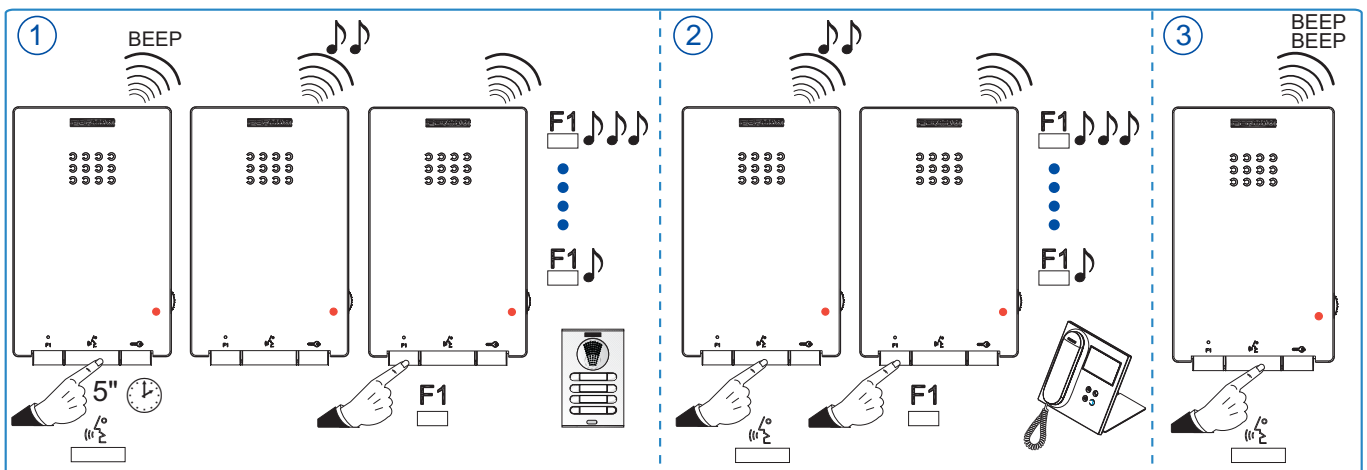

1. **Selection of call ring tone for outdoor panel:** With the telephone hung up and on standby mode, press the button for 5" until a "beep" sounds. Release the button and the current outdoor call melody will sound. Press the F1 button to select the melody (circular sequence). The last melody to play will be the one that is selected.

2. **Selection of call ring tone for guard unit:** While in "selection of melody from the outdoor panel" mode, press the button to select "melody configuration from the guard unit". The current guard unit melody will sound. Press the F1 button to select the melody (circular sequence). The last melody to play will be the one that is selected.

3. **Exit melody selection (standby mode):** While selecting melodies from the guard unit, making a short pulse on the button will exit the guard unit melody selection menu, returning to standby mode and storing the selected memory. This exit is confirmed by a double "beep".

*Note: In addition to this, the call ring tone selection process is exited after 10 seconds of inactivity (with the last melody reproduced being stored in the memory). This exit is confirmed by: Single "beep": from the outdoor panel and double "beep": from the guard unit.*

## TECHNICAL SPECIFICATIONS

Power supply	18 Vdc
Standby consumption + LED	18 mA
Maximum consumption	210 mA
Maximum conversation time	90 seconds
6-digit address	000001...999999
Operating temperature	[-5° , +40°C] / [23° , 104°F]
Dimensions	146 x 90 x 20mm (Height x Width x Depth)
Choice of call melodies	
Number of conversation channels (audio-only installation):	2 per bus
Conversation modes	
hands-free	by default
simplex	push to talk: push button  to talk, release to listen



## 8. DUOX RELAY

The DUOX Relay provides DUOX installations with a potential-free relay, with several configurable operating and activation modes:

- Activation of the relay through commands generated by the apartment terminals, outdoor panels or guard units.

- External activation through pushbuttons, additional external switches and so on.

The relay is supplied with power from the DUOX bus and can be installed in any part of the bus. It is possible to install one or more relays, per apartment, block or installation. Programming is via the pushbuttons of the relay itself. There is no need for additional programming elements, although configuration with the DUOX programmer is also possible.

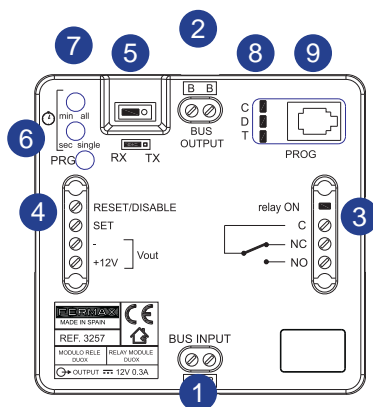

- 1 **B B: BUS INPUT** connector  
Input connector.
- 2 **B B: BUS OUTPUT** connector  
Output connector.
- 3 **Potential-free relay contacts (max. 3A.):**
  - C: Common.
  - NC: Normally closed.
  - NO: Normally open.
- 4 **External relay control:**
  - RESET / DISABLE, - : Disables any action upon the relay (originating from the command or from external activation), during the time in which both terminals are short circuited.
  - SET, - : Activation of the relay by external contact. Relay action when creating a short circuit between the SET and - (negative) terminals.
  - +12V: 12Vdc voltage auxiliary output (max. 300 mA.).
- 5 **Operating mode:**
  - TX: Mode in which the relay sends commands to other devices depending on the command that has been configured. In this mode the relay does not activate its output.
  - RX: Mode in which the relay activates its output if it receives the configured command through the bus and coincides with the parameters that have been configured.
- 6 **PRG**  
Pushbutton to enter programming mode.
- 7 **min all / sec single: Pushbuttons for Functions and Activation Times**
  - For Functions: Together with the PRG pushbutton (enter programming mode pushbutton), pressing will program the different possible relay functions.
  - For Activation Times:
    - Timed activation: Enables the configuration of the relay activation time between 1 and 120 seconds and between 1 and 120 minutes in the range of minutes.
    - Bistable: With the activation of the SET terminal, it remains permanently activated until deactivation is performed through the RESET terminal.
- 8 **C, D, T**  
LED diodes which provide information during the programming process based on the status: switched off, switched on, rapid blinking and so on.
- 9 **PROG: Telephone connector**  
For the connection of the DUOX programmer.

The relay has several **configurable operating modes**:

**1- RX Mode.** The relay **activates its output** when it receives the configured programmed command.

The usual functions normally include:

- Activation of the relay when effectuating the release.
- Activation of the relay when generating a call from the outdoor panel to the apartment.
- Activation of the relay when a call to the concierge is received.
- Activation of the relay when effectuating auto switch-on.
- Activation or deactivation of the relay upon activating relay F1.
- Activation or deactivation of the relay upon activating relay F2.
- Activation or deactivation of the relay activated/deactivated from "SET" and "-".

**2- TX Mode.** In this mode the relay **does not activate its output**. Other functions may be performed from a pushbutton connected between "SET" and "-".

- Lock release function upon receiving a call.
- Lock release function to a configured outdoor panel.
- Call to guard unit function.
- Activation or deactivation of relay F1 function.
- Activation or deactivation of relay F2 function.
- Activation or deactivation of remote relay function.

**Other configurations:**

- Configuration of activation times through integrated pushbuttons.
- Parameter reset.

These functions are outlined in detail in the [Manual code 97822 DUOX Advanced Relay Manual](#), available online.

## TECHNICAL SPECIFICATIONS

Power supply	18 Vdc
Standby consumption	28 mA
Maximum consumption	64 mA ( <i>without output load and without programmer</i> )
+12V	12 Vdc voltage auxiliary output (max. 300mA.)
Potential-free relay contacts.	
C	Common
NC	Normally closed
NO	Normally open
Operating temperature	[0° , +40°C] / [32° , 104°F]
Maximum relay contact current	3 A.
Maximum relay tension voltage	300VAC or 60VDC.

## 9. DUOX INSTALLATIONS

### 9.1 PRIOR CONSIDERATIONS REGARDING WIRING AND DUOX CONSUMPTION

DUOX is characterised by its level of flexibility in terms of the use of different cable types. In replacement works, it functions with existing wiring from previous door entry and video door entry installations. Some of the cables supported by DUOX include:

- Parallel
- UTP
- 5-wire cables
- 4+N installations

For optimum operation, it is advisable to use a 2x1mm<sup>2</sup> parallel cable (Ref. 5925).

Minimum cable section in DUOX 0.2mm<sup>2</sup> (UTP).

**In terms of wiring, it is best to avoid:**

- Unipolar cables, loose wires (electrical installation cables) and conductors of varying length.
- Changes to the type of cable or section throughout the installation.
- Doubled cables (attaching 2 cables to expand a section), in distribution installations.

Notes:

- Cables can be doubled in cascade installations.
- Using a cable with a larger section than the recommended section does not guarantee an improved system operation.

### CONSUMPTION TABLES Maximum number of terminals per power supply set.

#### FLOOR DISTRIBUTION (4 apartments per floor)

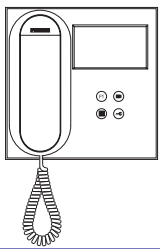
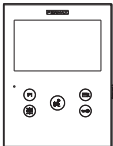
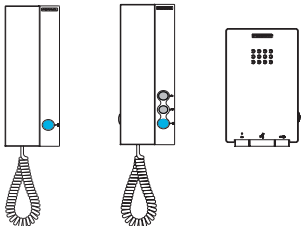
Device	VEO Monitor: 	VEO XS Monitor 	Telephone: 
Cable section			
1.0 mm <sup>2</sup>	36	30	72
0.5 mm <sup>2</sup>	32	26	48
0.2 mm <sup>2</sup> (UTP)	20	16	32

#### CASCADE

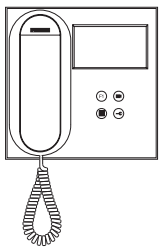
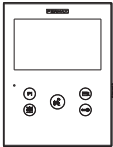
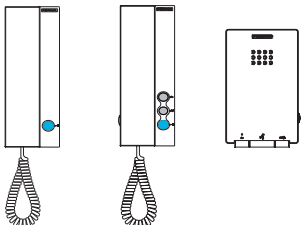
Device	VEO Monitor: 	VEO XS Monitor 	Telephone 
Cable section			
1.0 mm <sup>2</sup>	10 Monitors x 4 Risers (up to 24 in 1 Riser)	8 Monitors x 4 Risers (up to 20 in 1 Riser)	20 Telephones x 4 Risers (up to 32 in 1 Riser)
0.5 mm <sup>2</sup>	10 Monitors x 4 Risers (up to 20 in 1 Riser)	8 Monitors x 4 Risers (up to 18 in 1 Riser)	12 Telephones x 4 Risers (up to 28 in 1 Riser)
0.2 mm <sup>2</sup> (UTP)	9 Monitors x 4 Risers (up to 12 in 1 Riser)	7 Monitors x 4 Risers (up to 8 in 1 Riser)	10 Telephones x 4 Risers (up to 20 in 1 Riser)

## 9.2 BASIC VIDEO INSTALLATIONS (Monitors) AND MIXED INSTALLATIONS (Monitors + Telephones)

The term “Basic DUOX Installation” makes reference to installations that can be set up without regenerators.

It is characterised by:

- Including the following devices:
  - Outdoor panel
  - Power supply set
  - Monitors and Telephones.
  - Line adapters
- Including up to 40 apartment terminals distributed in a maximum of 4 risers.
- Distances fall between those in the table that will be displayed below.

**TABLE: Maximum distance from the outdoor panel to the first fork: D**

	CASCADE	2 Terminals x Storey	4 Terminals x Storey	6 Terminals x Storey
<b>D</b>	1 Riser	45 metres	45 metres	35 metres
	2 Risers	30 metres	30 metres	30 metres
	3 Risers	15 metres	15 metres	15 metres
	4 Risers	15 metres	-	-

Note: In CASCADE the distance will be the distance from the outdoor panel to the first monitor.

### 9.2.1 EXAMPLE OF A DUOX BASIC INSTALLATION. 1 RISER

**TABLE: Maximum distance from the outdoor panel to the first fork: D**

	CASCADE	2 Terminals x Storey	4 Terminals x Storey	6 Terminals x Storey
<b>D</b>	1 Riser	45 metres	45 metres	35 metres

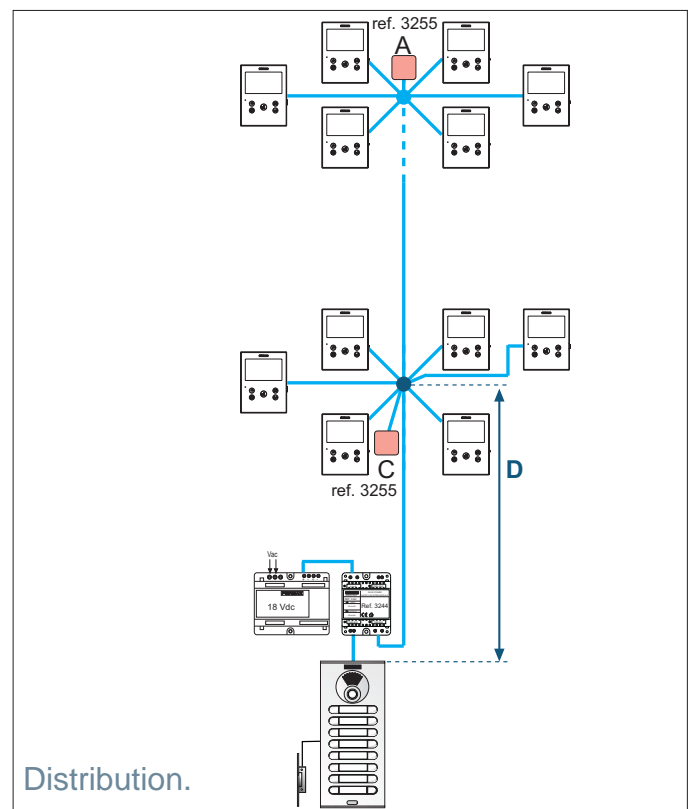
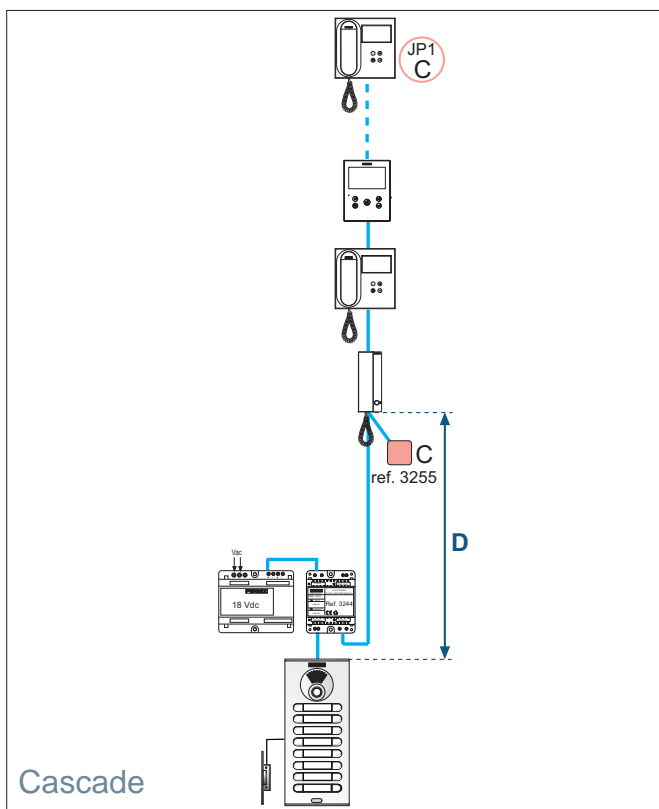

9.2.2 EXAMPLE OF A DUOX BASIC INSTALLATION. 2 RISERS

TABLE: Maximum distance from the outdoor panel to the first fork: **D**

		CASCADE	2 Terminals x Storey	4 Terminals x Storey	6 Terminals x Storey
<b>D</b>	2 Risers	30 metres	30 metres	30 metres	-

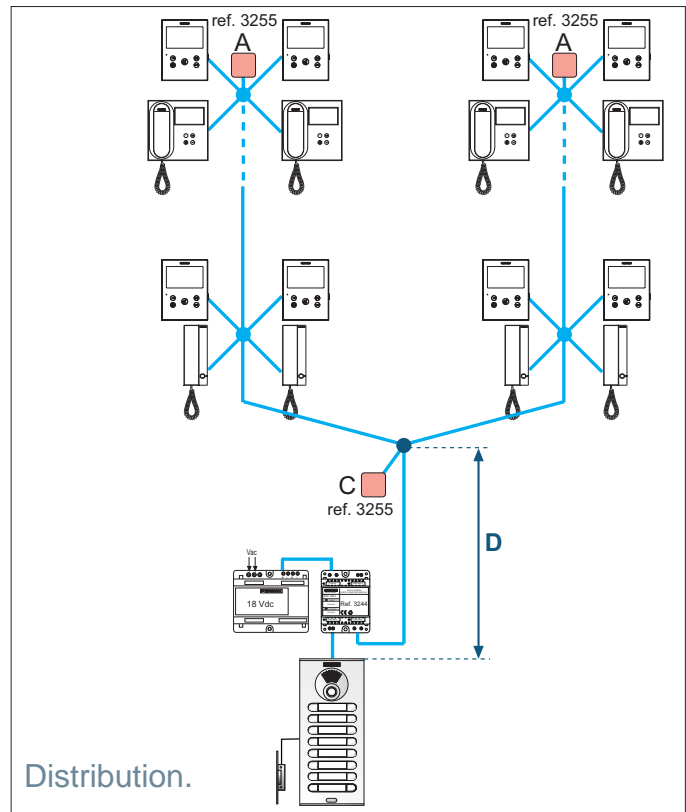
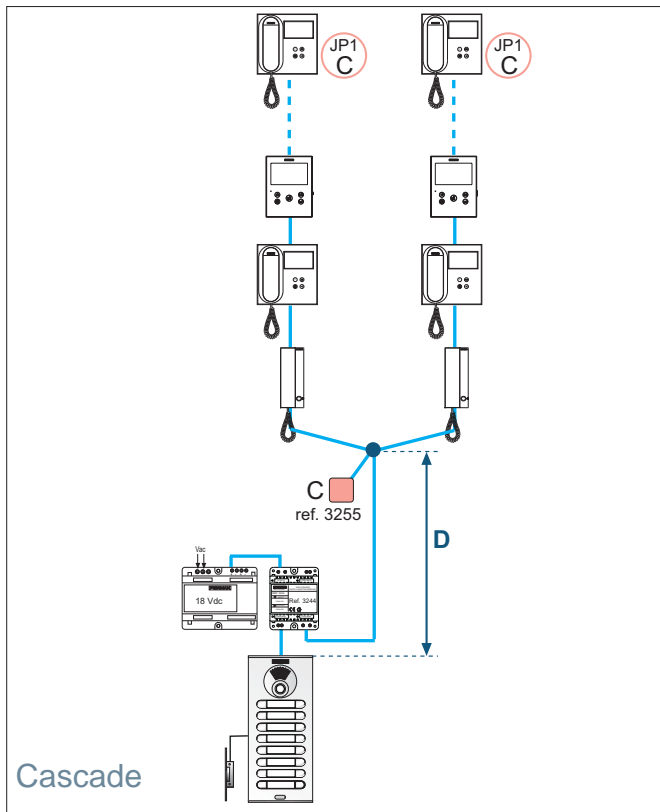

9.2.3 EXAMPLE OF A DUOX BASIC INSTALLATION. 3 RISERS

TABLE: Maximum distance from the outdoor panel to the first fork: **D**

		CASCADE	2 Terminals x Storey	4 Terminals x Storey	6 Terminals x Storey
<b>D</b>	3 Risers	15 metres	15 metres	15 metres	-

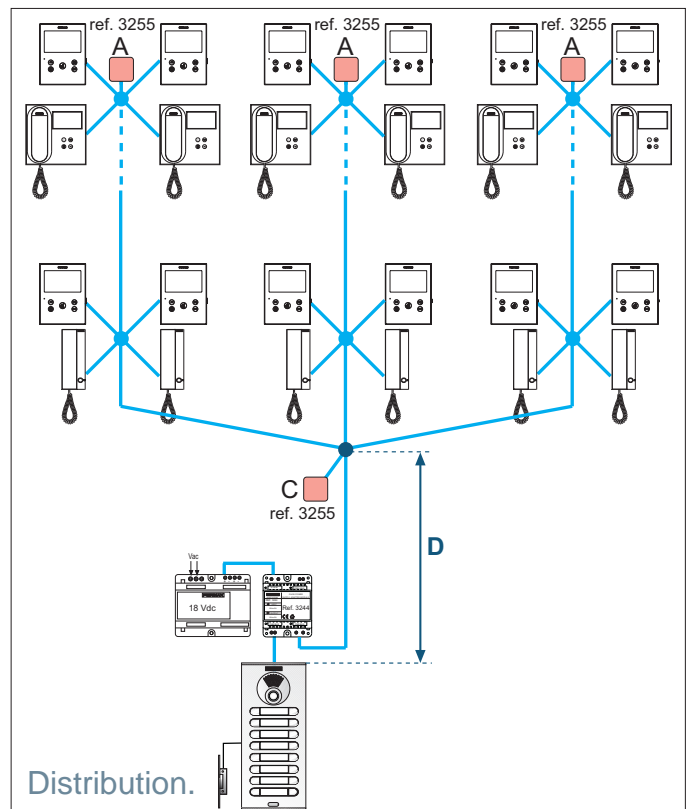
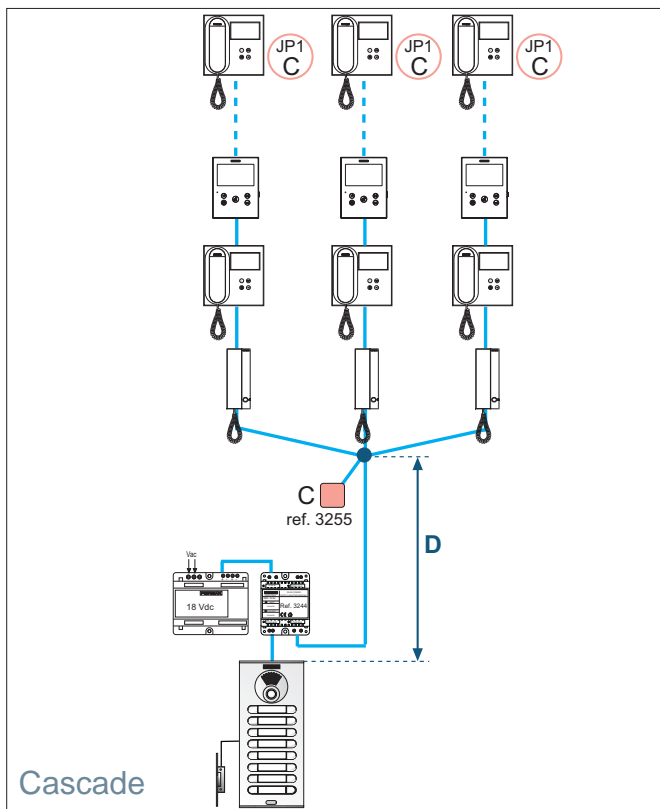

### 9.2.4 EXAMPLE OF A DUOX BASIC INSTALLATION. 4 RISERS

TABLE: Maximum distance from the outdoor panel to the first fork: **D**

	CASCADE	2 Terminals x Storey	4 Terminals x Storey	6 Terminals x Storey
<b>D</b> 4 Risers	15 metres	-	-	-

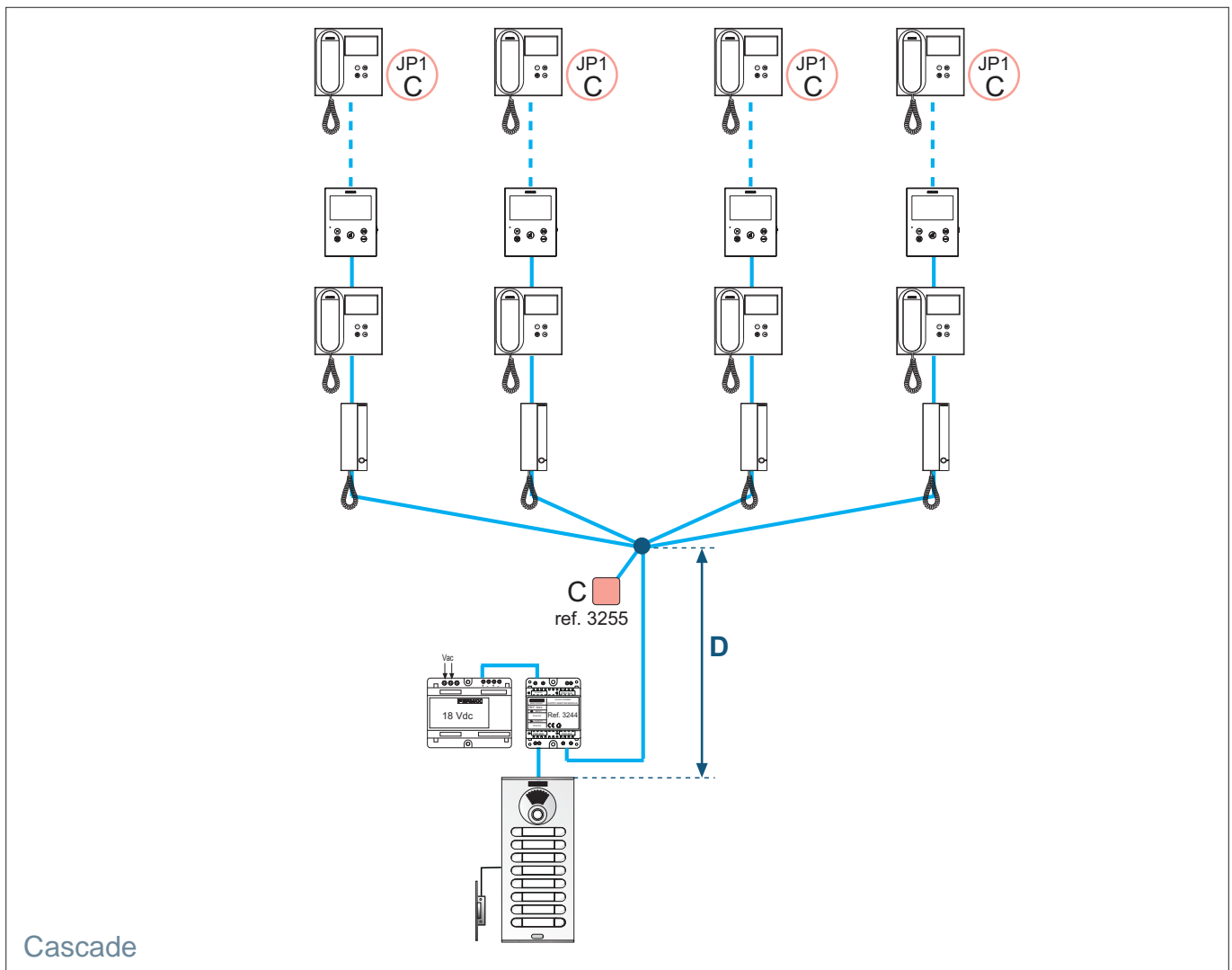

### 9.3 BASIC AUDIO INSTALLATION (Telephones)

The term “Basic DUOX Audio Installation” makes reference to the entirety of the installation that can be set up without regenerators.

It is characterised by:

- Including the following devices:
  - Outdoor panel
  - Power supply set
  - Telephones.
  - Line adapters
- Including up to 200 telephones distributed in a maximum of 4 risers with up to 4 terminals per storey.
- The maximum distance between the outdoor panel and the first fork: **D**, must not exceed 30 metres.



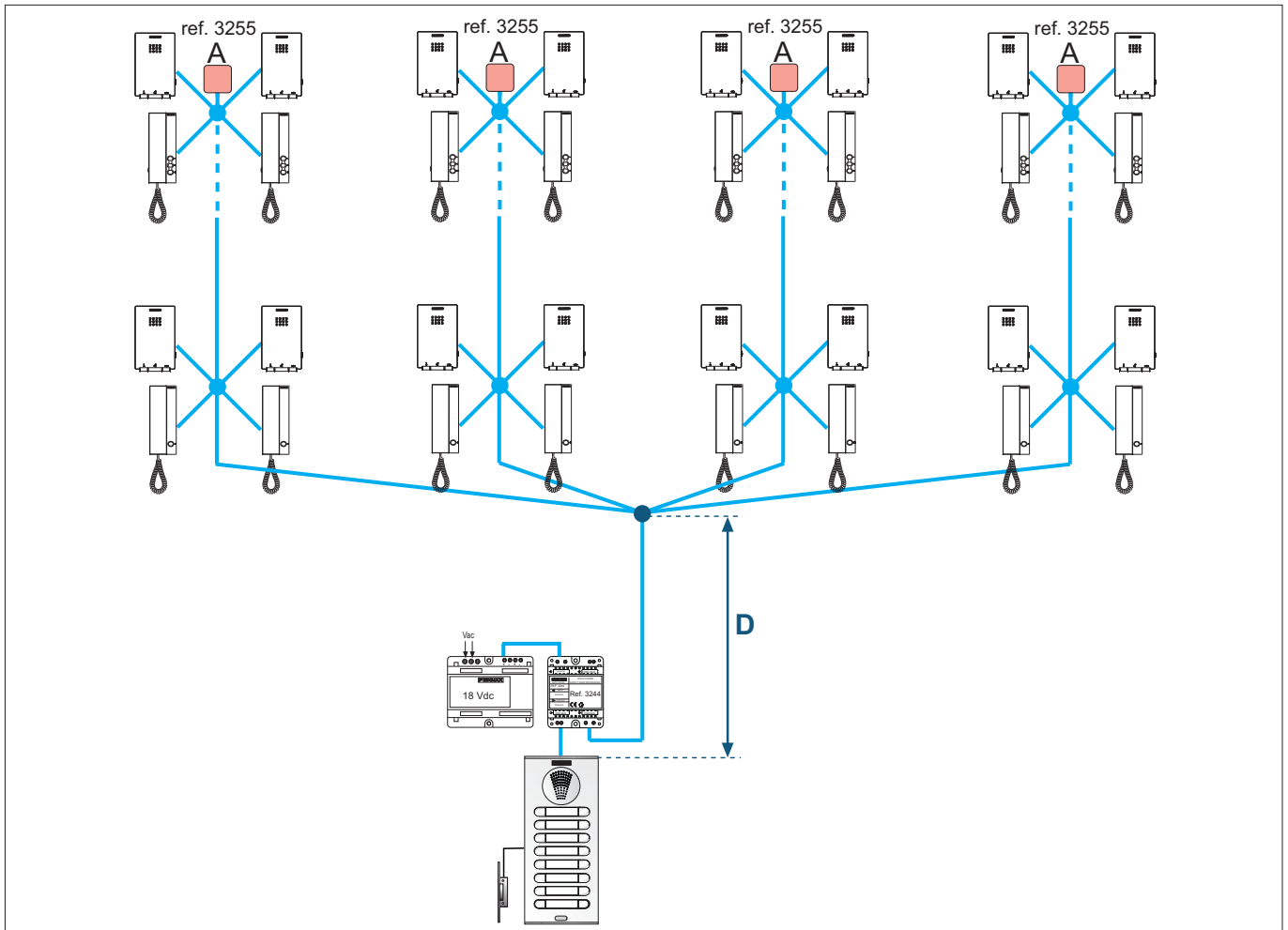

### 9.4 EXTENDED INSTALLATION

An “Extended Installation” refers to any installation that exceeds the technical specifications indicated in a Basic Installation.

In order to set up these installations it is necessary to use regenerators.

Possible uses and applications:

- **Increasing the distance between the outdoor panel and the first fork.**

See the Distances Table / Cables and Examples section.

**TABLE: Distance / Cable section** (between the outdoor panel and the first fork): **D**

		Cable section		
		2 x 1.0 mm <sup>2</sup>	2 x 0.5 mm <sup>2</sup>	2 x 0.2 mm <sup>2</sup>
<b>D (distance)</b>	Regenerator <b>WITHOUT</b> a power supply set in the outdoor panel	200 metres	150 metres	40 metres
	Regenerator <b>WITH</b> a power supply set in the outdoor panel	500 metres	500 metres	500 metres

Example 1: Regenerator **WITHOUT** a power supply set in the outdoor panel

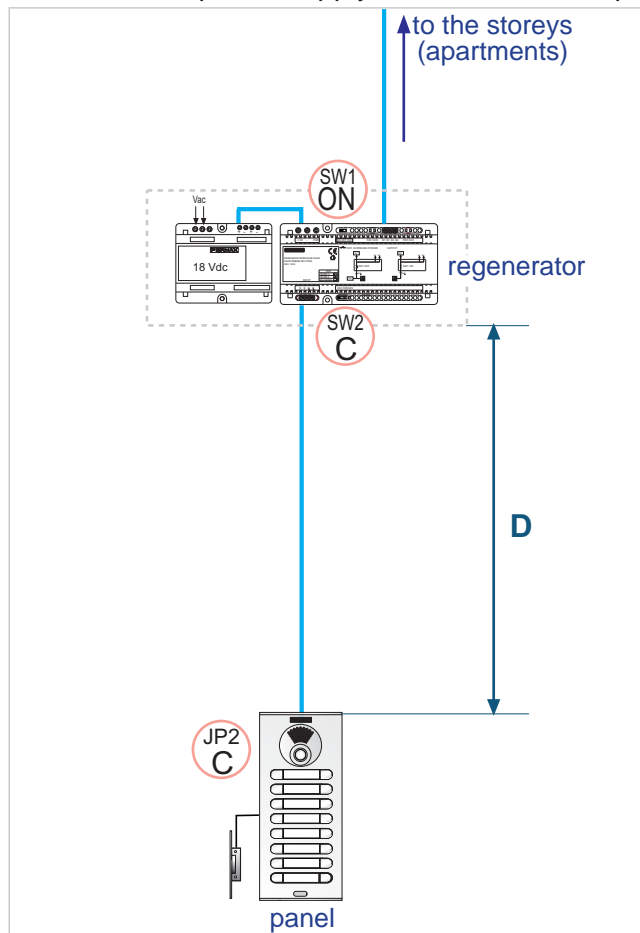

Example 2: Regenerator **WITH** a power supply set in the outdoor panel

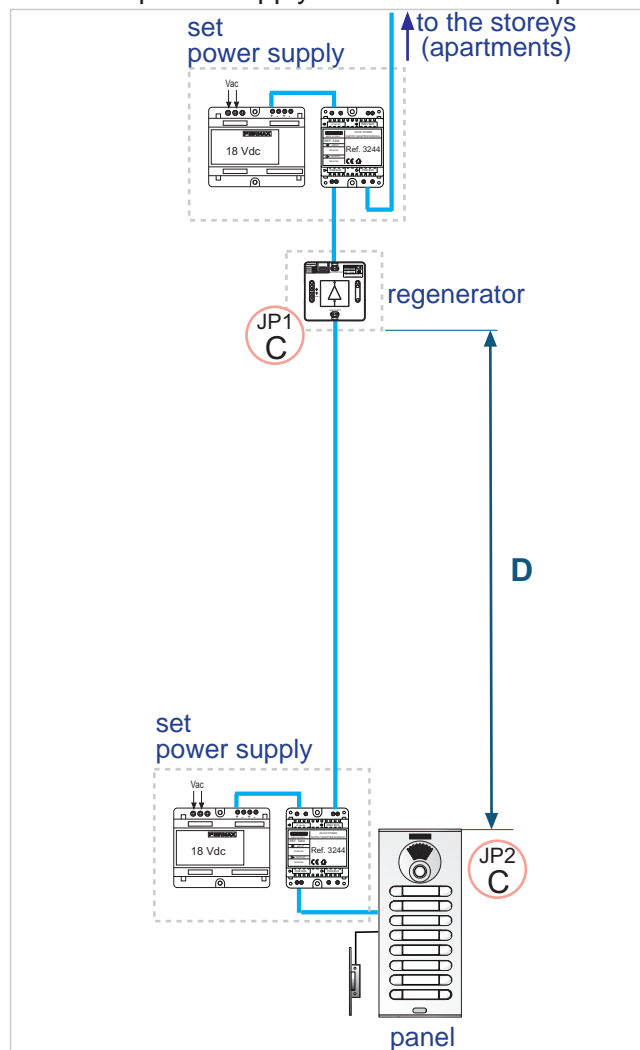

- Dividing an extended installation into several basic installations.

See Example.

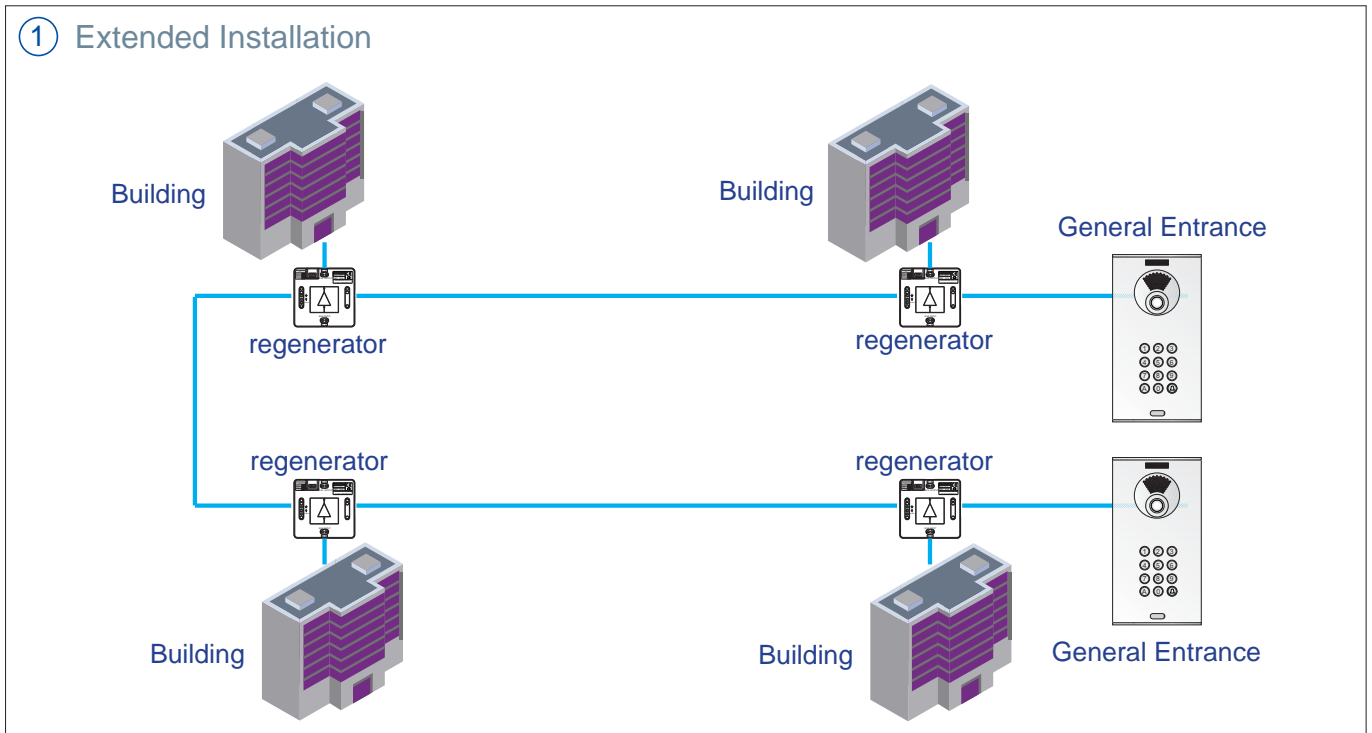

Extended Installation = 4 x Building Installation + Regenerator bus and General Entrances.

①

②

③

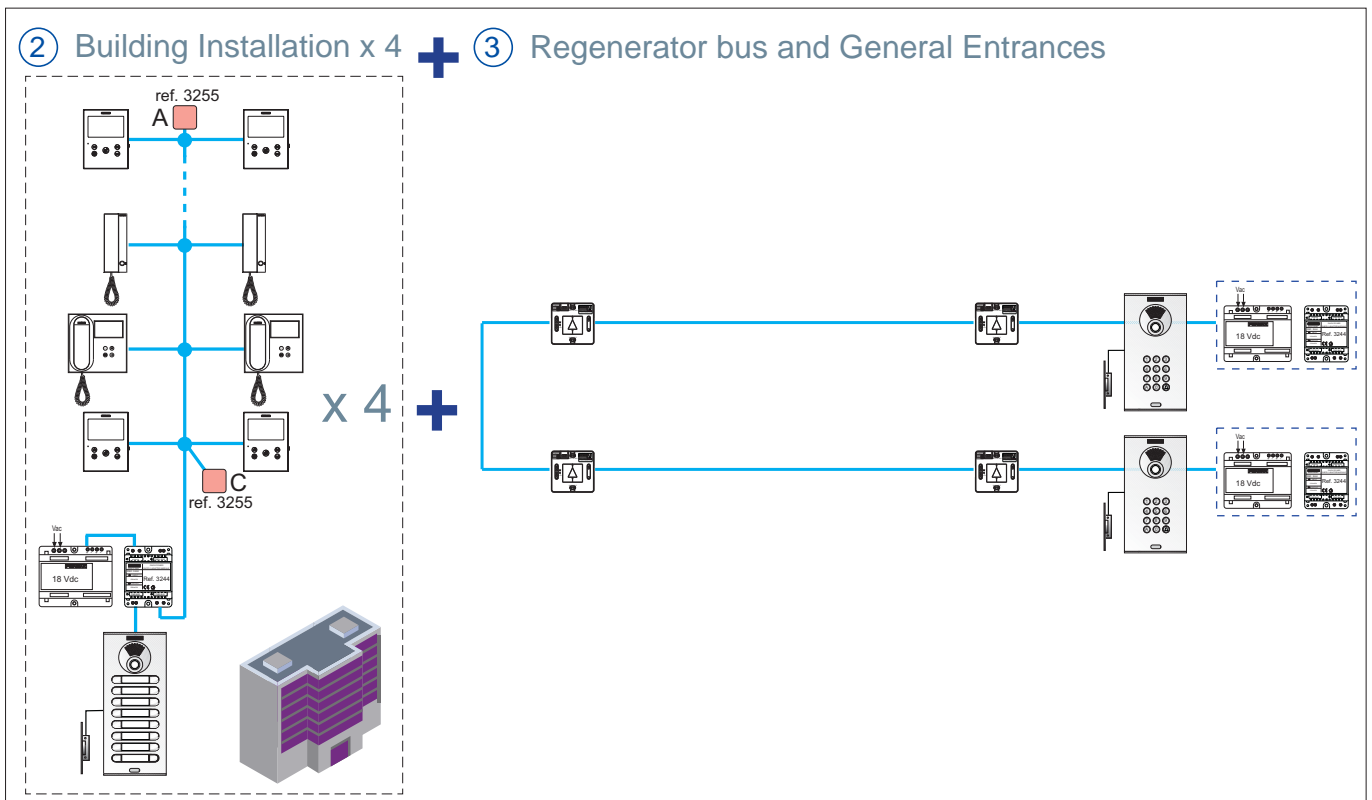

**FERMAX**

Avd. Tres Cruces, 133  
46017 Valencia  
Spain